

ENERGIZER EN22

9V



Specifications

Classification: Alkaline
Chemical System: Zinc-Manganese Dioxide (Zn/MnO₂)
 No added mercury or cadmium
Designation: IEC-6LF22 ANSI-1604A
Nominal Voltage: 9.0 volts
Operating Temp: -18°C to 55°C
Typical Weight: 45.0 grams (1.58 oz.)
Typical Volume: 21.1 cubic centimeters
Shelf Life: 5 years at 21°C
Terminal: Miniature Snap

Industry Standard Dimensions

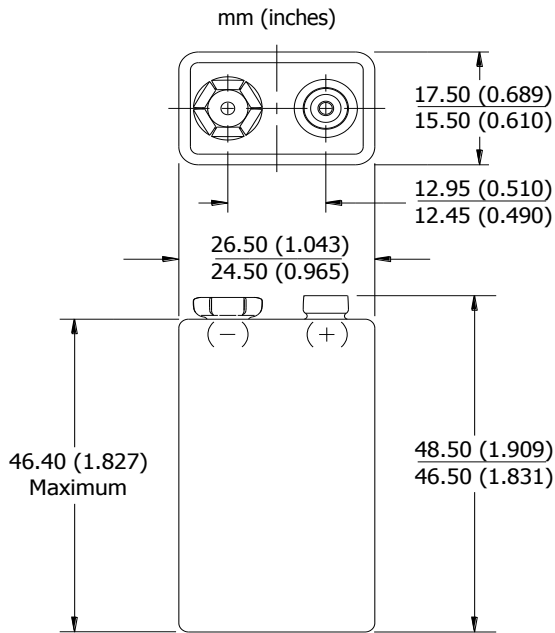

Continuous Discharge

to 4.8 volts at 21°C

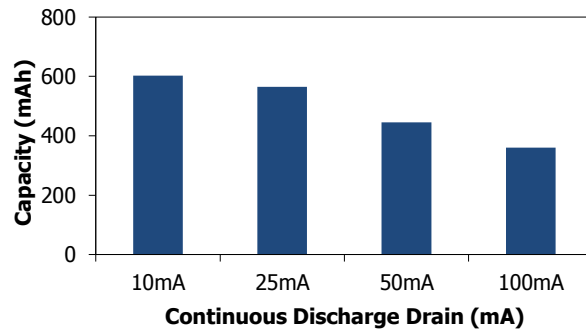

Industry Standard Tests (21°C)

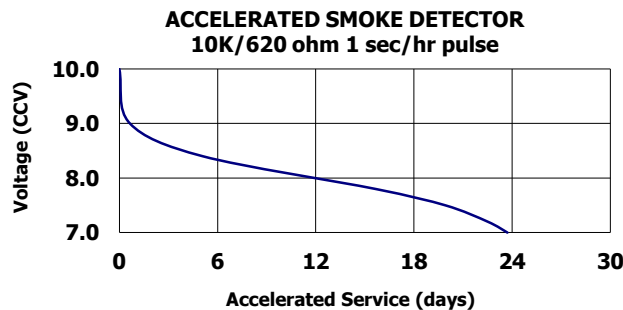
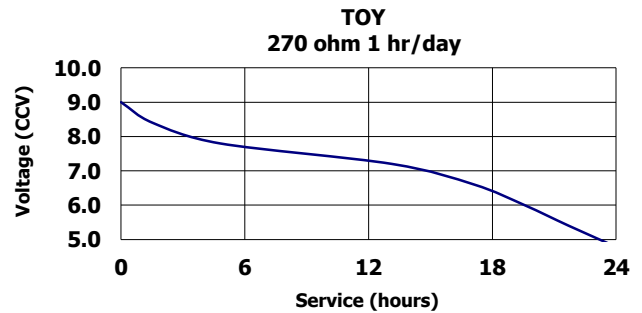
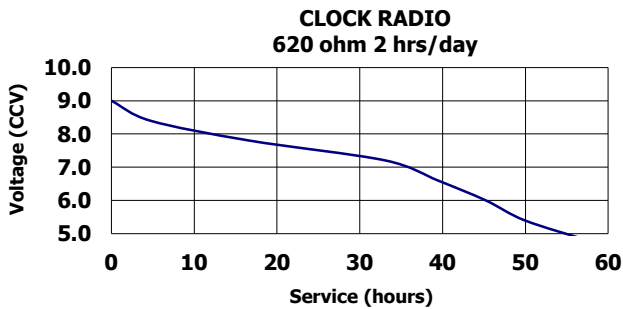

Important Notice

This data sheet contains typical information specific to products manufactured at the time of its publication.
Contents herein do not constitute a warranty and are for reference only.