

REV.	DESCRIPTION	DATE	APPROVED
A	Engineering Update w/o Changes	02/23/04	M. C.
B	Changed Dimension	04/06/06	M. C.
C	Updated Material Notes	12/17/13	G. W.
D	Removed Material Code	05/22/16	J. C.

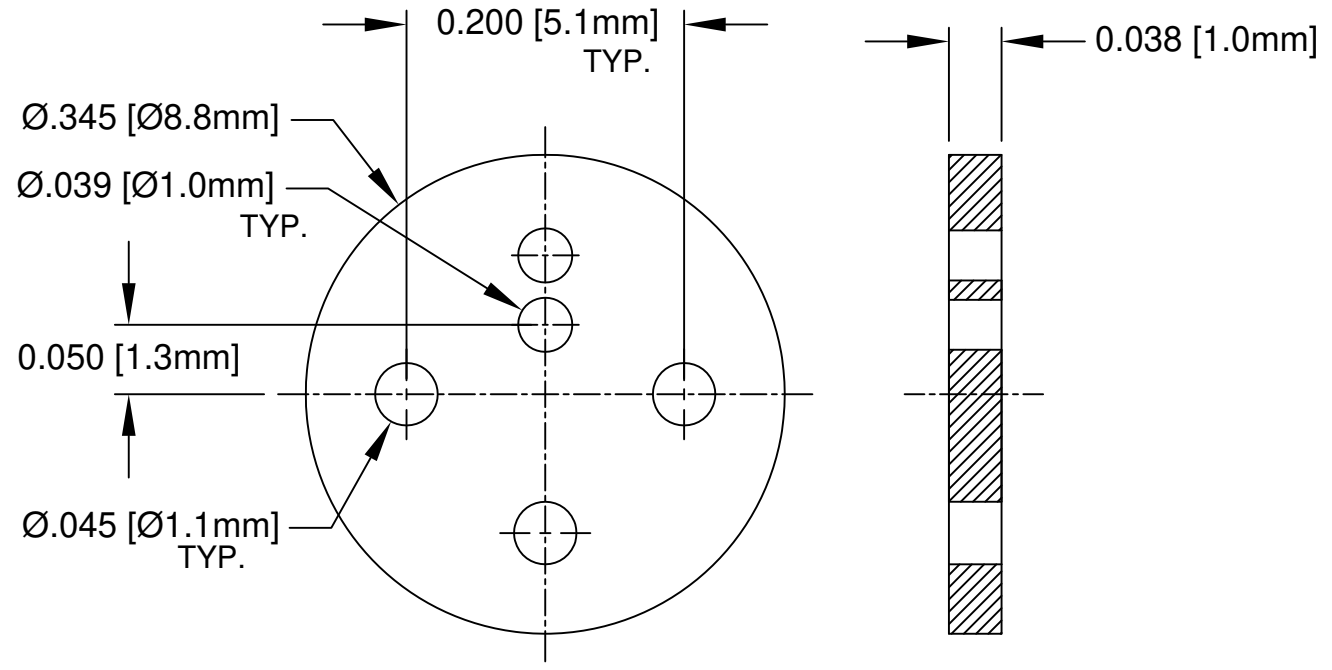

2. MATERIAL: NYLON 6/6, 94V-2, NATURAL.

1. GENERAL SPECIFICATIONS: BIVAR MOLDED COMPONENT SPECIFICATION BV00-E101.

STANDARD TOLERANCE ( UNLESS OTHERWISE SPECIFIED )		BIVAR®	
DECIMALS	ANGULAR	4 THOMAS, IRVINE, CA. 92618	
.X ± .1	X° ± 1°	TEL: (949) 951-8808 FAX: (949) 951-3974	
.XX ± .01		TITLE: PERM-O-PAD TO-5 MOUNT	
.XXX ± .005		PART NO: 506-038	
DESIGNED: S. Irving	DATE: 09/15/98	REVISION: D	
CHECKED: M. Chen	DATE: 09/23/03	CAGE CODE : 32559	SHEET # 1 OF 1
CAD GENERATED DOCUMENT. DO NOT MEASURE DRAWING.			