

## Features

- Temperature ranges
  - Industrial: -40°C to 85°C
  - Automotive-A: -40°C to 85°C
  - Automotive-E: -40°C to 125°C
- Pin and function compatible with CY7C1011BV33
- High speed
  - $t_{AA} = 10$  ns (Industrial and Automotive-A)
  - $t_{AA} = 12$  ns (Automotive-E)
- Low active power
  - 360 mW (max) (Industrial and Automotive-A)
- Data Retention at 2.0
- Automatic power down when deselected
- Independent control of upper and lower bits
- Easy memory expansion with  $\overline{CE}$  and  $\overline{OE}$  features
- Available in Pb-free 44-pin TSOP II, 44-pin TQFP and non Pb-free 48-Ball VFBGA packages

## Functional Description

The CY7C1011CV33 is a high performance CMOS static RAM organized as 131,072 words by 16 bits. This device has an automatic power down feature that significantly reduces power consumption when deselected.

To write to the device, take Chip Enable ( $\overline{CE}$ ) and Write Enable (WE) inputs LOW. If Byte Low Enable (BLE) is LOW, then data from I/O pins (I/O<sub>0</sub> through I/O<sub>7</sub>), is written into the location specified on the address pins (A<sub>0</sub> through A<sub>16</sub>). If Byte High Enable (BHE) is LOW, then data from I/O pins (I/O<sub>8</sub> through I/O<sub>15</sub>) is written into the location specified on the address pins (A<sub>0</sub> through A<sub>16</sub>).

To read from the device, take Chip Enable ( $\overline{CE}$ ) and Output Enable ( $\overline{OE}$ ) LOW while forcing the Write Enable (WE) HIGH. If Byte Low Enable (BLE) is LOW, then data from the memory location specified by the address pins appear on I/O<sub>0</sub> to I/O<sub>7</sub>. If Byte High Enable ( $\overline{BHE}$ ) is LOW, then data from memory appears on I/O<sub>8</sub> to I/O<sub>15</sub>. For more information, see the “Truth Table” on page 9 for a complete description of Read and Write modes.

The input and output pins (I/O<sub>0</sub> through I/O<sub>15</sub>) are placed in a high impedance state when the device is deselected ( $\overline{CE}$  HIGH), the outputs are disabled ( $\overline{OE}$  HIGH), the BHE and BLE are disabled (BHE, BLE HIGH), or during a write operation ( $\overline{CE}$  LOW and WE LOW).

For best practice recommendations, refer to the Cypress application note [AN1064, SRAM System Guidelines](#).

## Logic Block Diagram

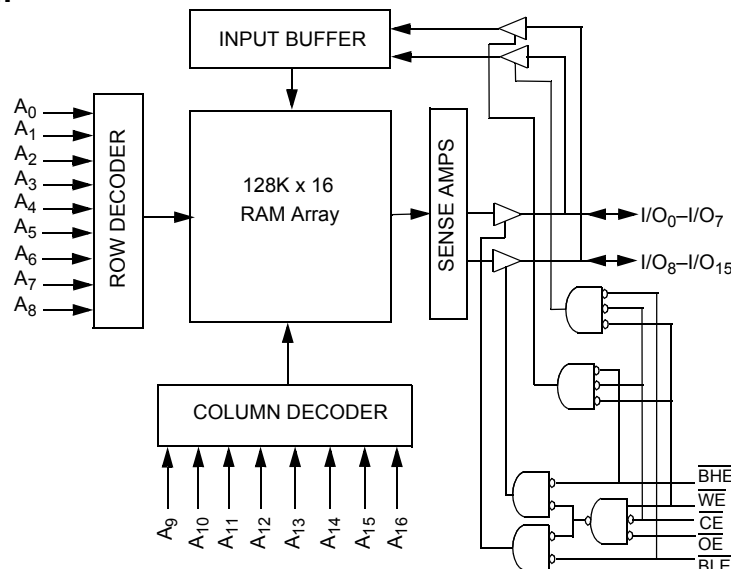



**Selection Guide**

Description		-10	-12	Unit
Maximum Access Time		10	12	ns
Maximum Operating Current	Industrial	100	95	mA
	Automotive-A	100		mA
	Automotive-E		120	mA
Maximum CMOS Standby Current	Industrial	10	10	mA
	Automotive-A	10		mA
	Automotive-E		15	mA

### Maximum Ratings

Exceeding maximum ratings may impair the useful life of the device. These user guidelines are not tested.

- Storage Temperature ..... -65°C to +150°C
- Ambient Temperature with Power Applied ..... -55°C to +125°C
- Supply Voltage on V<sub>CC</sub> Relative to GND<sup>[2]</sup> ..... -0.5V to +4.6V
- DC Voltage Applied to Outputs in High Z State<sup>[2]</sup> ..... -0.5V to V<sub>CC</sub>+0.5V
- DC Input Voltage<sup>[2]</sup> ..... -0.5V to V<sub>CC</sub>+0.5V

- Current into Outputs (LOW) ..... 20 mA
- Static Discharge Voltage..... >2001V (MIL-STD-883, Method 3015)
- Latch Up Current ..... >200 mA

### Operating Range

Range	Ambient Temperature (T <sub>A</sub> )	V <sub>CC</sub>
Industrial	-40°C to +85°C	3.3V ± 10%
Automotive-A	-40°C to +85°C	
Automotive -E	-40°C to +125°C	

### Electrical Characteristics

Over the Operating Range

Parameter	Description	Test Conditions	-10		-12		Unit	
			Min	Max	Min	Max		
V <sub>OH</sub>	Output HIGH Voltage	V <sub>CC</sub> = Min, I <sub>OH</sub> = -4.0 mA	2.4		2.4		V	
V <sub>OL</sub>	Output LOW Voltage	V <sub>CC</sub> = Min, I <sub>OL</sub> = 8.0 mA		0.4		0.4	V	
V <sub>IH</sub>	Input HIGH Voltage		2.0	V <sub>CC</sub> + 0.3	2.0	V <sub>CC</sub> + 0.3	V	
V <sub>IL</sub>	Input LOW Voltage <sup>[2]</sup>		-0.3	0.8	-0.3	0.8	V	
I <sub>IX</sub>	Input Leakage Current	GND ≤ V <sub>I</sub> ≤ V <sub>CC</sub>	Industrial	-1	+1	-1	+1	μA
			Automotive-A	-1	+1			
			Automotive -E			-20	+20	
I <sub>OZ</sub>	Output Leakage Current	GND ≤ V <sub>I</sub> ≤ V <sub>CC</sub> , Output disabled	Industrial	-1	+1	-1	+1	μA
			Automotive-A	-1	+1			
			Automotive -E			-20	+20	
I <sub>CC</sub>	V <sub>CC</sub> Operating Supply Current	V <sub>CC</sub> = Max, I <sub>OUT</sub> = 0 mA, f = f <sub>MAX</sub> = 1/t <sub>RC</sub>	Industrial		100		95	mA
			Automotive-A		100			
			Automotive -E				120	
I <sub>SB1</sub>	Automatic CE Power Down Current — TTL Inputs	Max V <sub>CC</sub> , CE ≥ V <sub>IH</sub> , V <sub>IN</sub> ≥ V <sub>IH</sub> or V <sub>IN</sub> ≤ V <sub>IL</sub> , f = f <sub>MAX</sub>	Industrial		40		40	mA
			Automotive-A		40			
			Automotive -E				45	
I <sub>SB2</sub>	Automatic CE Power Down Current — CMOS Inputs	Max V <sub>CC</sub> , CE ≥ V <sub>CC</sub> - 0.3V, V <sub>IN</sub> ≥ V <sub>CC</sub> - 0.3V, or V <sub>IN</sub> ≤ 0.3V, f = 0	Industrial		10		10	mA
			Automotive-A		10			
			Automotive -E				15	

**Note**

2. V<sub>IL</sub> (min) = -2.0V for pulse durations of less than 20 ns.

## Capacitance

Tested initially and after any design or process changes that may affect these parameters.

Parameter	Description	Test Conditions	Max	Unit
C <sub>IN</sub>	Input Capacitance	T <sub>A</sub> = 25°C, f = 1 MHz, V <sub>CC</sub> = 3.3V	8	pF
C <sub>OUT</sub>	Output Capacitance		8	pF

## Thermal Resistance

Tested initially and after any design or process changes that may affect these parameters.

Parameter	Description	Test Conditions	TSOP II	TQFP	VFBGA	Unit
Θ <sub>JA</sub>	Thermal Resistance (Junction to Ambient)	Still Air, soldered on a 3 × 4.5 inch, four-layer printed circuit board	44.56	42.66	46.98	°C/W
Θ <sub>JC</sub>	Thermal Resistance (Junction to Case)		10.75	14.64	9.63	°C/W

Figure 4. AC Test Loads and Waveforms <sup>[3]</sup>

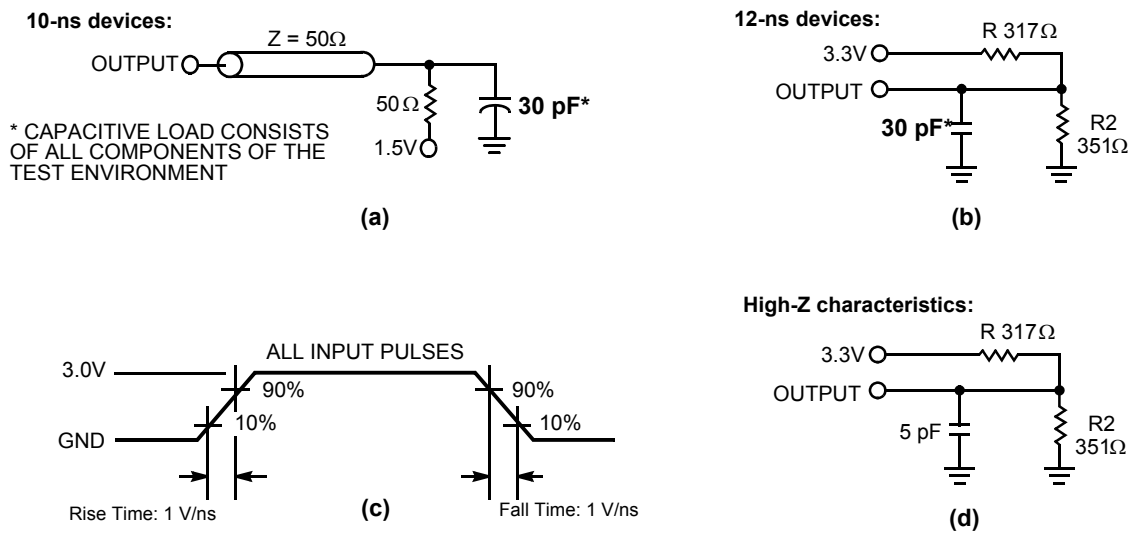

**Note**

3. AC characteristics (except High-Z) for 10-ns parts are tested using the load conditions shown in Figure 4 (a). All other speeds are tested using the Thevenin load shown in Figure 4 (b). High-Z characteristics are tested for all speeds using the test load shown in Figure 4 (d).

## Switching Characteristics

Over the Operating Range <sup>[4]</sup>

Parameter	Description	-10		-12		Unit
		Min	Max	Min	Max	
<b>Read Cycle</b>						
$t_{power}^{[5]}$	$V_{CC}$ (Typical) to the First Access	1		1		$\mu s$
$t_{RC}$	Read Cycle Time	10		12		ns
$t_{AA}$	Address to Data Valid		10		12	ns
$t_{OHA}$	Data Hold from Address Change	3		3		ns
$t_{ACE}$	$\overline{CE}$ LOW to Data Valid		10		12	ns
$t_{DOE}$	$\overline{OE}$ LOW to Data Valid	Industrial/Automotive-A			5	6
		Automotive-E				8
$t_{LZOE}$	$\overline{OE}$ LOW to Low Z <sup>[6]</sup>	0		0		ns
$t_{HZOE}$	$\overline{OE}$ HIGH to High Z <sup>[6, 7]</sup>		5		6	ns
$t_{LZCE}$	$\overline{CE}$ LOW to Low Z <sup>[6]</sup>	3		3		ns
$t_{HZCE}$	$\overline{CE}$ HIGH to High Z <sup>[6, 7]</sup>		5		6	ns
$t_{PU}$	$\overline{CE}$ LOW to Power Up	0		0		ns
$t_{PD}$	$\overline{CE}$ HIGH to Power Down		10		12	ns
$t_{DBE}$	Byte Enable to Data Valid	Industrial/Automotive-A			5	6
		Automotive-E				8
$t_{LZBE}$	Byte Enable to Low Z	0		0		ns
$t_{HZBE}$	Byte Disable to High Z		5		6	ns
<b>Write Cycle<sup>[8, 9]</sup></b>						
$t_{WC}$	Write Cycle Time	10		12		ns
$t_{SCE}$	$\overline{CE}$ LOW to Write End	7		8		ns
$t_{AW}$	Address Setup to Write End	7		8		ns
$t_{HA}$	Address Hold from Write End	0		0		ns
$t_{SA}$	Address Setup to Write Start	0		0		ns
$t_{PWE}$	$\overline{WE}$ Pulse Width	7		8		ns
$t_{SD}$	Data Setup to Write End	5		6		ns
$t_{HD}$	Data Hold from Write End	0		0		ns
$t_{LZWE}$	$\overline{WE}$ HIGH to Low Z <sup>[6]</sup>	3		3		ns
$t_{HZWE}$	$\overline{WE}$ LOW to High Z <sup>[6, 7]</sup>		5		6	ns
$t_{BW}$	Byte Enable to End of Write	7		8		ns

### Notes

- Test conditions assume signal transition time of 3 ns or less, timing reference levels of 1.5V, and input pulse levels of 0 to 3.0V.
- $t_{POWER}$  gives the minimum amount of time that the power supply is at typical  $V_{CC}$  values until the first memory access is performed.
- At any temperature and voltage condition,  $t_{HZCE}$  is less than  $t_{LZCE}$ ,  $t_{HZOE}$  is less than  $t_{LZOE}$ , and  $t_{HZWE}$  is less than  $t_{LZWE}$  for any device.
- $t_{HZOE}$ ,  $t_{HZBE}$ ,  $t_{HZCE}$ , and  $t_{HZWE}$  are specified with a load capacitance of 5 pF as in part (d) of "AC Test Loads and Waveforms <sup>[3]</sup>" on page 5. Transition is measured  $\pm 500$  mV from steady state voltage.
- The internal write time of the memory is defined by the overlap of  $\overline{CE}$  LOW,  $\overline{WE}$  LOW, and  $\overline{BHE/BLE}$  LOW.  $\overline{CE}$ ,  $\overline{WE}$ , and  $\overline{BHE/BLE}$  must be LOW to initiate a write. The transition of these signals terminate the write. The input data setup and hold timing is referenced to the leading edge of the signal that terminates the write.
- The minimum write cycle time for Write Cycle No. 3 (WE controlled,  $\overline{OE}$  LOW) is the sum of  $t_{HZWE}$  and  $t_{SD}$ .

### Switching Waveforms

Figure 5. Read Cycle No. 1 (Address Transition Controlled)<sup>[10, 11]</sup>

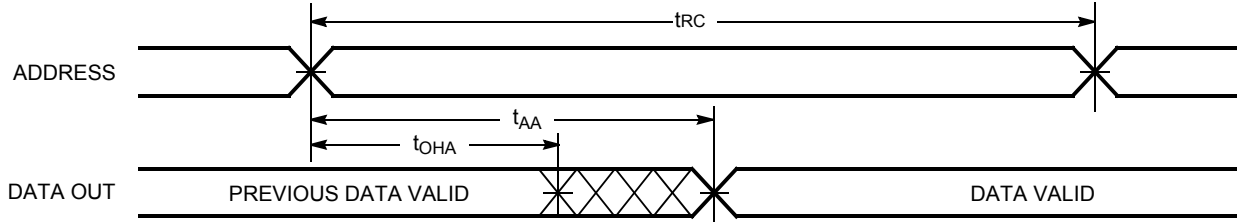
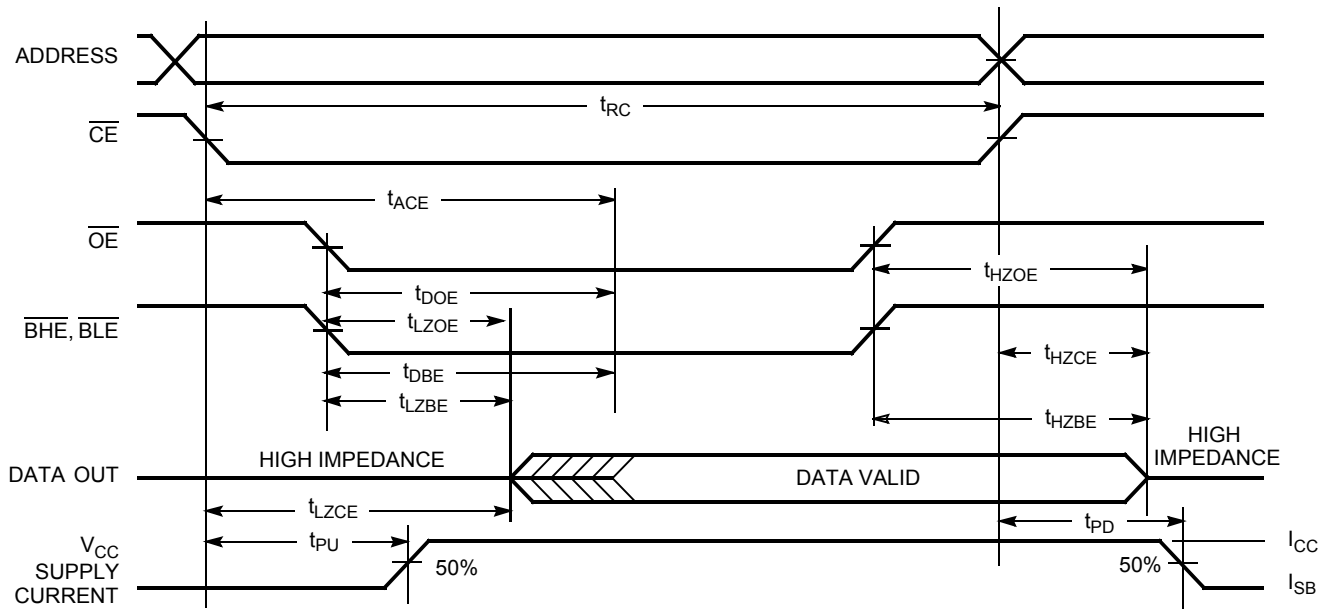

Figure 6. Read Cycle No. 2 ( $\overline{OE}$  Controlled)<sup>[11, 12]</sup>



**Notes**

- 10. Device is continuously selected.  $\overline{OE}$ ,  $\overline{CE}$ ,  $\overline{BHE}$ , and/or  $\overline{BLE}$  =  $V_{IL}$ .
- 11.  $\overline{WE}$  is HIGH for read cycle.
- 12. Address valid prior to or coincident with  $\overline{CE}$  transition LOW.

Switching Waveforms (continued)

Figure 7. Write Cycle No. 1 ( $\overline{\text{CE}}$  Controlled)<sup>[13, 14]</sup>

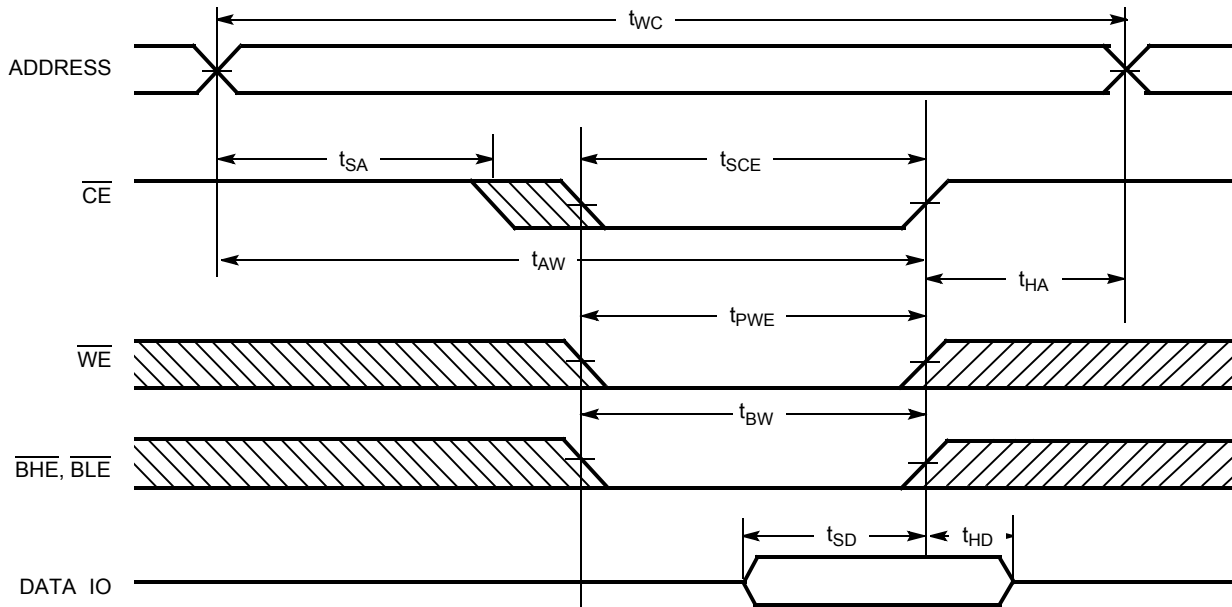
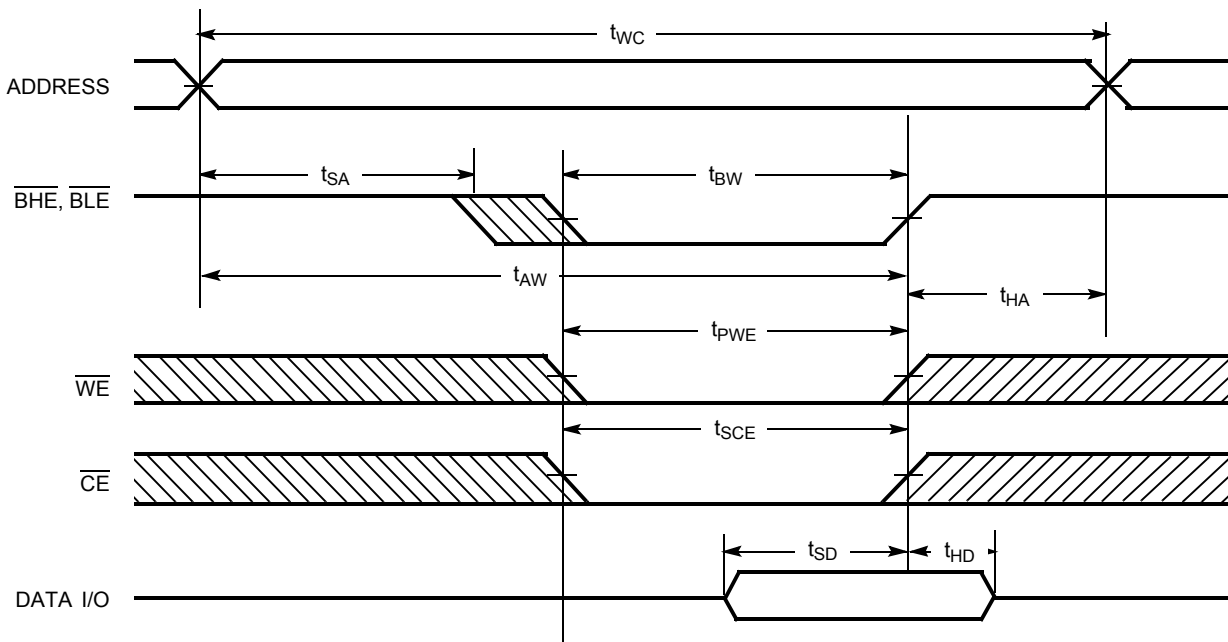

Figure 8. Write Cycle No. 2 ( $\overline{\text{BLE}}$  or  $\overline{\text{BHE}}$  Controlled)



Notes

13. Data I/O is high impedance if  $\overline{\text{OE}}$ ,  $\overline{\text{BHE}}$ , and/or  $\overline{\text{BLE}} = V_{IH}$ .

14. If  $\overline{\text{CE}}$  goes HIGH simultaneously with  $\overline{\text{WE}}$  going HIGH, the output remains in a high impedance state.



Switching Waveforms (continued)

Figure 9. Write Cycle No. 3 ( $\overline{WE}$  Controlled, LOW)

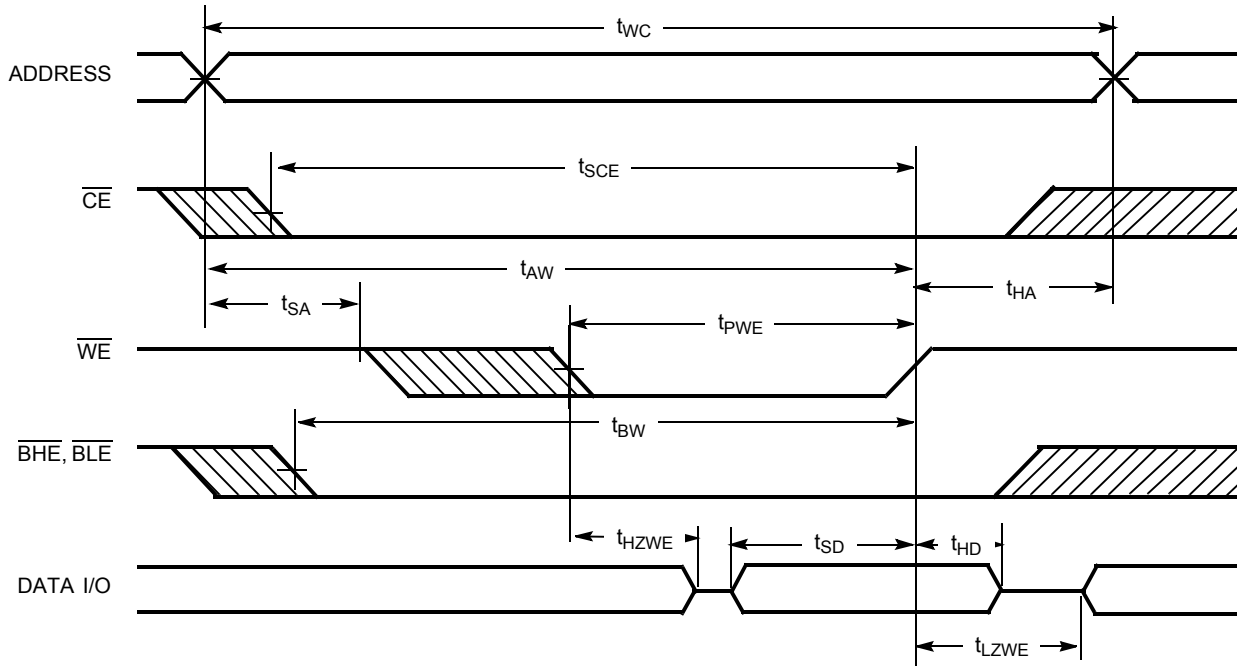

Truth Table

$\overline{CE}$	$\overline{OE}$	$\overline{WE}$	$\overline{BLE}$	$\overline{BHE}$	I/O <sub>0</sub> –I/O <sub>7</sub>	I/O <sub>8</sub> –I/O <sub>15</sub>	Mode	Power
H	X	X	X	X	High Z	High Z	Power Down	Standby ( $I_{SB}$ )
L	L	H	L	L	Data Out	Data Out	Read – All Bits	Active ( $I_{CC}$ )
L	L	H	L	H	Data Out	High Z	Read – Lower Bits Only	Active ( $I_{CC}$ )
L	L	H	H	L	High Z	Data Out	Read – Upper Bits Only	Active ( $I_{CC}$ )
L	X	L	L	L	Data In	Data In	Write – All Bits	Active ( $I_{CC}$ )
L	X	L	L	H	Data In	High Z	Write – Lower Bits Only	Active ( $I_{CC}$ )
L	X	L	H	L	High Z	Data In	Write – Upper Bits Only	Active ( $I_{CC}$ )
L	H	H	X	X	High Z	High Z	Selected, Outputs Disabled	Active ( $I_{CC}$ )

Ordering Information

Speed (ns)	Ordering Code	Package Diagram	Package Type	Operating Range
10	CY7C1011CV33-10BVI	51-85150	48-ball (6 x 8 x 1 mm) VFBGA	Industrial
	CY7C1011CV33-10ZSXA	51-85087	44-pin TSOP II (Pb-Free)	Automotive-A
12	CY7C1011CV33-12AXI	51-85064	44-pin TQFP (Pb-Free)	Industrial
	CY7C1011CV33-12ZSXE	51-85087	44-pin TSOP II (Pb-Free)	Automotive-E

Package Diagrams

Figure 10. 44-Pin Thin Small Outline Package Type II, 51-85087

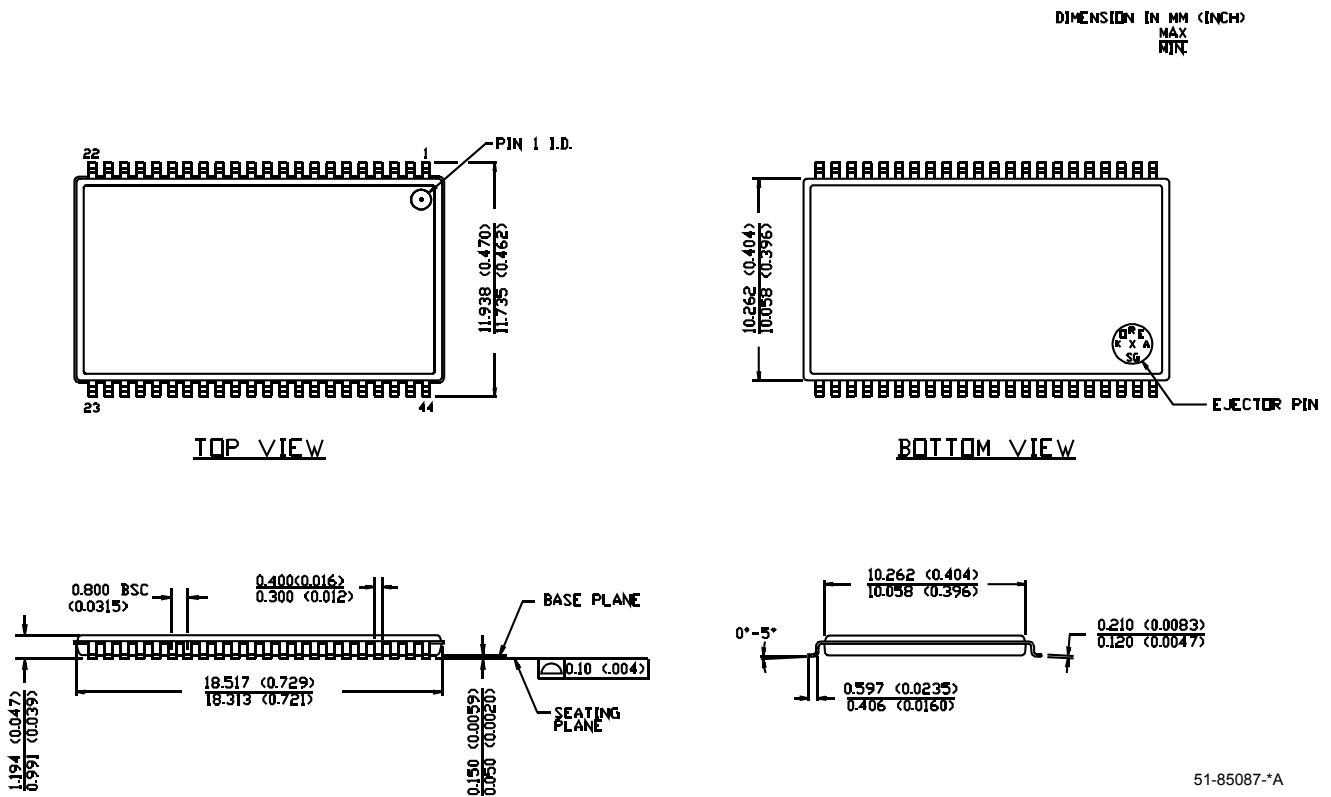

Package Diagrams (continued)

Figure 11. 44-Pin Thin Plastic Quad Flat Pack, 51-85064

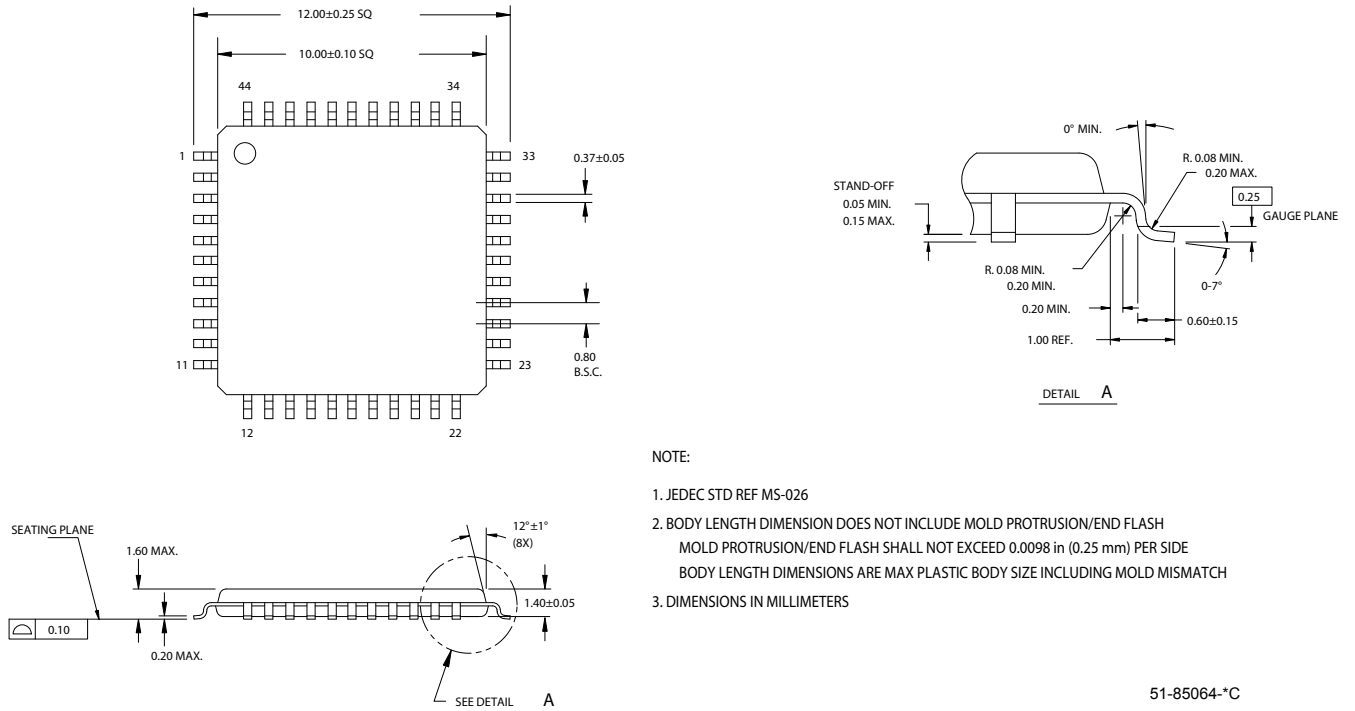

NOTE:

1. JEDEC STD REF MS-026
2. BODY LENGTH DIMENSION DOES NOT INCLUDE MOLD PROTRUSION/END FLASH  
MOLD PROTRUSION/END FLASH SHALL NOT EXCEED 0.0098 in (0.25 mm) PER SIDE  
BODY LENGTH DIMENSIONS ARE MAX PLASTIC BODY SIZE INCLUDING MOLD MISMATCH
3. DIMENSIONS IN MILLIMETERS

51-85064-°C

Package Diagrams (continued)

Figure 12. 48-Ball VFBGA (6 x 8 x 1 mm), 51-85150

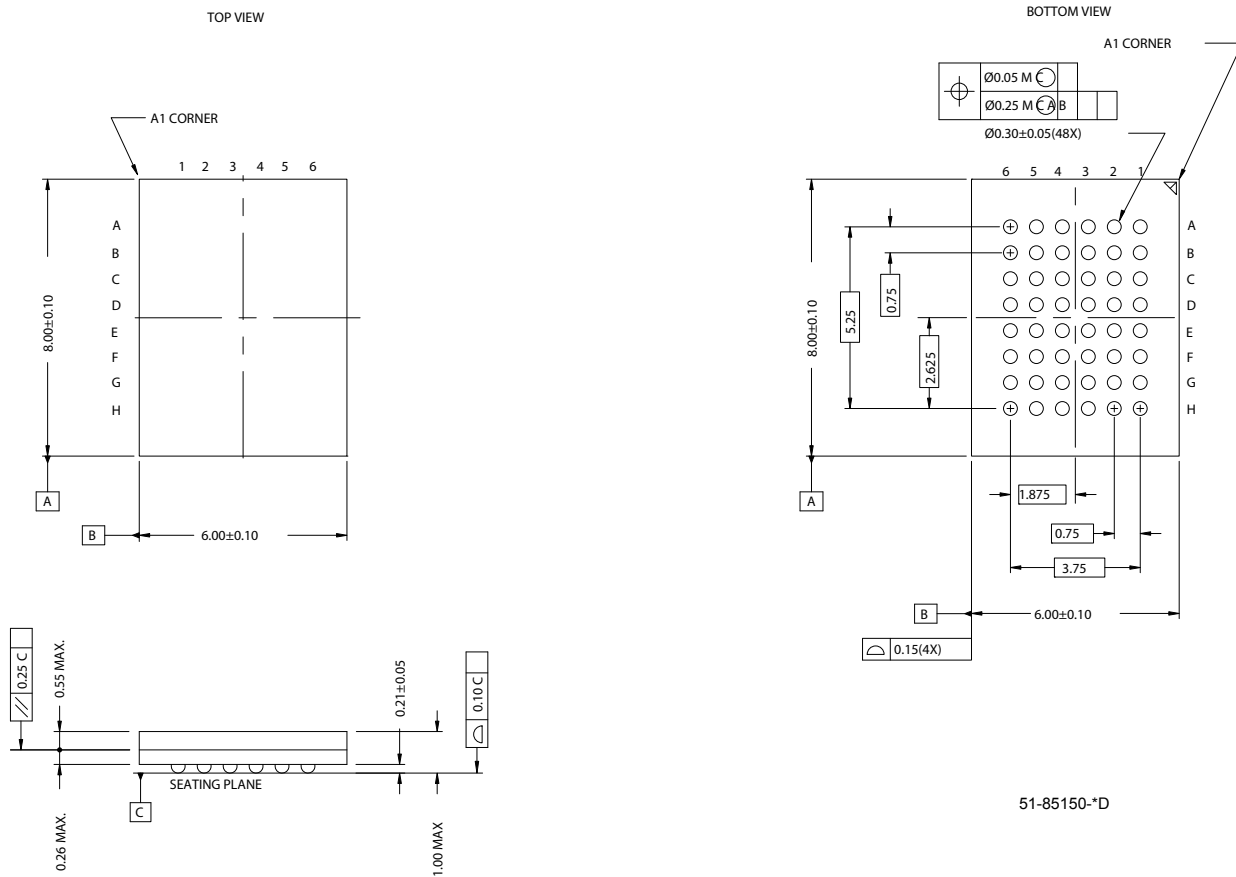

Document History Page

Document Title: CY7C1011CV33, 2-Mbit (128K x 16) Static RAM				
Document Number: 38-05232				
REV.	ECN NO.	Issue Date	Orig. of Change	Description of Change
**	117132	07/31/02	HGK	New Data Sheet
*A	118057	08/19/02	HGK	Pin configuration for 48-ball FBGA correction
*B	119702	10/11/02	DFP	Updated FBGA to VFBGA; updated package code on page 8 to BV48A. Updated address pinouts on page 1 to A0 to A16. Updated CMOS standby current on page 1 from 8 to 10 mA
*C	386106	See ECN	PCI	Added lead-free parts in Ordering Information Table
*D	498501	See ECN	NXR	Corrected typo in the Logic Block Diagram on page# 1 Included the Maximum Ratings for Static Discharge Voltage and Latch up Current on page# 3 Changed the description of I <sub>IX</sub> from Input Load Current to Input Leakage Current in DC Electrical Characteristics table Updated the Ordering Information Table
*E	522620	See ECN	VKN	Added Thermal Resistance Table
*F	1891366	See ECN	VKN/AESA	Added -10ZSXA part Updated Ordering Information table
*G	2428606	See ECN	VKN/PYRS	Corrected typo in the 44-Pin TSOP and 48-Ball FBGA pinout Removed Commercial parts Removed 15 ns speed bin Removed inactive parts from the Ordering Information table
*H	2664421	02/25/09	VKN/AESA	Added Automotive-E specs for 12 ns speed Updated Ordering Information table

Sales, Solutions, and Legal Information

Worldwide Sales and Design Support

Cypress maintains a worldwide network of offices, solution centers, manufacturer’s representatives, and distributors. To find the office closest to you, visit us at [cypress.com/sales](http://cypress.com/sales).

Products

- PSoC [psoc.cypress.com](http://psoc.cypress.com)
- Clocks & Buffers [clocks.cypress.com](http://clocks.cypress.com)
- Wireless [wireless.cypress.com](http://wireless.cypress.com)
- Memories [memory.cypress.com](http://memory.cypress.com)
- Image Sensors [image.cypress.com](http://image.cypress.com)

PSoC Solutions

- General [psoc.cypress.com/solutions](http://psoc.cypress.com/solutions)
- Low Power/Low Voltage [psoc.cypress.com/low-power](http://psoc.cypress.com/low-power)
- Precision Analog [psoc.cypress.com/precision-analog](http://psoc.cypress.com/precision-analog)
- LCD Drive [psoc.cypress.com/lcd-drive](http://psoc.cypress.com/lcd-drive)
- CAN 2.0b [psoc.cypress.com/can](http://psoc.cypress.com/can)
- USB [psoc.cypress.com/usb](http://psoc.cypress.com/usb)

© Cypress Semiconductor Corporation, 2009. The information contained herein is subject to change without notice. Cypress Semiconductor Corporation assumes no responsibility for the use of any circuitry other than circuitry embodied in a Cypress product. Nor does it convey or imply any license under patent or other rights. Cypress products are not warranted nor intended to be used for medical, life support, life saving, critical control or safety applications, unless pursuant to an express written agreement with Cypress. Furthermore, Cypress does not authorize its products for use as critical components in life-support systems where a malfunction or failure may reasonably be expected to result in significant injury to the user. The inclusion of Cypress products in life-support systems application implies that the manufacturer assumes all risk of such use and in doing so indemnifies Cypress against all charges.

Any Source Code (software and/or firmware) is owned by Cypress Semiconductor Corporation (Cypress) and is protected by and subject to worldwide patent protection (United States and foreign), United States copyright laws and international treaty provisions. Cypress hereby grants to licensee a personal, non-exclusive, non-transferable license to copy, use, modify, create derivative works of, and compile the Cypress Source Code and derivative works for the sole purpose of creating custom software and/or firmware in support of licensee product to be used only in conjunction with a Cypress integrated circuit as specified in the applicable agreement. Any reproduction, modification, translation, compilation, or representation of this Source Code except as specified above is prohibited without the express written permission of Cypress.

Disclaimer: CYPRESS MAKES NO WARRANTY OF ANY KIND, EXPRESS OR IMPLIED, WITH REGARD TO THIS MATERIAL, INCLUDING, BUT NOT LIMITED TO, THE IMPLIED WARRANTIES OF MERCHANTABILITY AND FITNESS FOR A PARTICULAR PURPOSE. Cypress reserves the right to make changes without further notice to the materials described herein. Cypress does not assume any liability arising out of the application or use of any product or circuit described herein. Cypress does not authorize its products for use as critical components in life-support systems where a malfunction or failure may reasonably be expected to result in significant injury to the user. The inclusion of Cypress’ product in a life-support systems application implies that the manufacturer assumes all risk of such use and in doing so indemnifies Cypress against all charges.

Use may be limited by and subject to the applicable Cypress software license agreement.