

REVISIONS

LTR	DESCRIPTION	DATE (YR-MO-DA)	APPROVED
A	Add device type 02. Add package Y. Correct table I, I _{CC} . Editorial changes throughout.	92-01-16	Monica Poelking
B	Changes in accordance with NOR 5962-R058-94	93-12-02	Tim Noh
C	Changes in accordance with NOR 5962-R025-95	94-11-15	Thomas M. Hess
D	Add device 03. Editorial changes throughout.	95-09-26	Monica Poelking

REV																				
SHEET																				
REV	D	D	D	D	D	D	D	D	D	D	D									
SHEET	15	16	17	18	19	20	21	22	23	24	25									
REV STATUS OF SHEETS			REV			D	D	D	D	D	D	D	D	D	D	D	D	D	D	D
			SHEET			1	2	3	4	5	6	7	8	9	10	11	12	13	14	
PMIC N/A			PREPARED BY Todd D. Creek						DEFENSE ELECTRONICS SUPPLY CENTER DAYTON, OHIO 45444											
STANDARD MICROCIRCUIT DRAWING THIS DRAWING IS AVAILABLE FOR USE BY ALL DEPARTMENTS AND AGENCIES OF THE DEPARTMENT OF DEFENSE AMSC N/A			CHECKED BY Ray Monnin																	MICROCIRCUIT, DIGITAL, CMOS, 32-BIT DMA CONTROLLER WITH INTEGRATED SYSTEM SUPPORT PERIPHERALS, MONOLITHIC SILICON
			APPROVED BY Michael Frye																	
			DRAWING APPROVAL DATE 89-06-23																	
						REVISION LEVEL D						SIZE A	CAGE CODE 67268	5962-89593						
									SHEET 1 OF 25											

1. SCOPE

1.1 Scope. This drawing describes device requirements for class B microcircuits in accordance with 1.2.1 of MIL-STD-883, "Provisions for the use of MIL-STD-883 in conjunction with compliant non-JAN devices".

1.2 Part or Identifying Number (PIN). The complete PIN shall be as shown in the following example:



1.2.1 Device type(s). The device type(s) shall identify the circuit function as follows:

<u>Device type</u>	<u>Generic number</u>	<u>Circuit function</u>	<u>Frequency</u>
01	82380	32-bit DMA controller with integrated system support peripherals	16 MHz
02	82380	32-bit DMA controller with integrated system support peripherals	20 MHz
03	82380	32-bit DMA controller with integrated system support peripherals	25 MHz

1.2.2 Case outline(s). The case outline(s) shall be as designated in MIL-STD-1835 and as follows:

<u>Outline letter</u>	<u>Descriptive designator</u>	<u>Terminals</u>	<u>Package style</u>
Y	See figure 1	164	Leaded chip carrier leads
Z	CMGA6-P132	132	Pin grid array package

1.2.3 Lead finish. The lead finish shall be as specified in MIL-STD-883 (see 3.1 herein). Finish letter "X" shall not be marked on the microcircuit or its packaging. The "X" designation is for use in specifications when lead finishes A, B, and C are considered acceptable and interchangeable without preference.

1.3 Absolute maximum ratings.

Storage temperature range - - - - -	-65°C to +150°C
Voltage on any pin with respect to ground - - - - -	-0.5 V dc to +6.5 V dc
Power dissipation (P _D) - - - - -	2.0 W
Lead temperature (soldering, 10 seconds) - - - - -	+300°C
Thermal resistance, junction-to-case (θ _{JC}):	
Case Z - - - - -	See MIL-STD-1835
Case Y - - - - -	+8°C/W
Junction temperature (T _J) - - - - -	+175°C

1.4 Recommended operating conditions.

Case operating temperature range (T _C) - - - - -	-55°C to +125°C
Supply voltage range (V _{CC}) - - - - -	+4.75 V dc to +5.25 V dc

2. APPLICABLE DOCUMENTS

2.1 Government specification, standards, and bulletin. Unless otherwise specified, the following specification, standards, and bulletin of the issue listed in that issue of the Department of Defense Index of Specifications and Standards specified in the solicitation, form a part of this drawing to the extent specified herein.

SPECIFICATION

MILITARY

MIL-I-38535 - Integrated Circuits (Microcircuits) Manufacturing, General Specification for.

STANDARD MICROCIRCUIT DRAWING DEFENSE ELECTRONICS SUPPLY CENTER DAYTON, OHIO 45444	SIZE A	5962-89593	
	REVISION LEVEL D	SHEET 2	

STANDARDS

MILITARY

- MIL-STD-883 - Test Methods and Procedures for Microelectronics.
- MIL-STD-1835 - Microcircuit Case Outlines.

BULLETIN

MILITARY

- MIL-BUL-103 - List of Standardized Military Drawings (SMD's).

(Copies of the specification, standards, and bulletin required by manufacturers in connection with specific acquisition functions should be obtained from the contracting activity or as directed by the contracting activity.)

2.2 Order of precedence. In the event of a conflict between the text of this drawing and the references cited herein, the text of this drawing shall take precedence.

3. REQUIREMENTS

3.1 Item requirements. The individual item requirements shall be in accordance with 1.2.1 of MIL-STD-883, "Provisions for the use of MIL-STD-883 in conjunction with compliant non-JAN devices" and as specified herein. Product built to this drawing that is produced by a Qualified Manufacturer Listing (QML) certified and qualified manufacturer or a manufacturer who has been granted transitional certification to MIL-I-38535 may be processed as QML product in accordance with the manufacturers approved program plan and qualifying activity approval in accordance with MIL-I-38535. This QML flow as documented in the Quality Management (QM) plan may make modifications to the requirements herein. These modifications shall not affect form, fit, or function of the device. These modifications shall not affect the PIN as described herein. A "Q" or "QML" certification mark in accordance with MIL-I-38535 is required to identify when the QML flow option is used.

3.2 Design, construction, and physical dimensions. The design, construction, and physical dimensions shall be as specified in MIL-STD-883 (see 3.1 herein) and herein.

3.2.1 Case outline(s). The case outline(s) shall be in accordance with 1.2.2 herein and figure 1.

3.2.2 Terminal connections. The terminal connections shall be as specified on figure 2.

3.2.3 Functional block diagram. The functional block diagram shall be as specified on figure 3.

3.3 Electrical performance characteristics. Unless otherwise specified herein, the electrical performance characteristics are as specified in table I and shall apply over the full case operating temperature range.

3.4 Electrical test requirements. The electrical test requirements shall be the subgroups specified in table II. The electrical tests for each subgroup are described in table I.

3.5 Marking. Marking shall be in accordance with MIL-STD-883 (see 3.1 herein). The part shall be marked with the PIN listed in 1.2 herein. In addition, the manufacturer's PIN may also be marked as listed in MIL-BUL-103 (see 6.6 herein).

3.6 Certificate of compliance. A certificate of compliance shall be required from a manufacturer in order to be listed as an approved source of supply in MIL-BUL-103 (see 6.6 herein). The certificate of compliance submitted to DESC-EC prior to listing as an approved source of supply shall affirm that the manufacturer's product meets the requirements of MIL-STD-883 (see 3.1 herein) and the requirements herein.

3.7 Certificate of conformance. A certificate of conformance as required in MIL-STD-883 (see 3.1 herein) shall be provided with each lot of microcircuits delivered to this drawing.

3.8 Notification of change. Notification of change to DESC-EC shall be required in accordance with MIL-STD-883 (see 3.1 herein).

3.9 Verification and review. DESC, DESC's agent, and the acquiring activity retain the option to review the manufacturer's facility and applicable required documentation. Offshore documentation shall be made available onshore at the option of the reviewer.

STANDARD MICROCIRCUIT DRAWING DEFENSE ELECTRONICS SUPPLY CENTER DAYTON, OHIO 45444	SIZE A		5962-89593
		REVISION LEVEL D	SHEET 3

TABLE 1. Electrical performance characteristics.

Test	Symbol	Conditions -55°C ≤ T _C ≤ +125°C unless otherwise specified	Group A subgroups	Device type	Limits		Unit
					Min	Max	
Input low voltage	V _{IL}		1,2,3	A11	-0.3 1/	0.8	V
Input high voltage	V _{IH}		1,2,3		2.0	V _{CC} 1/ 0.3	V
CLK2 input low voltage	V _{ILC}		1,2,3		-0.3 1/	0.8	V
CLK2 input high voltage	V _{IHC}		1,2,3		V _{CC} 0.8	V _{CC} 1/ 0.3	V
Output low voltage	V _{OL}	I _{OL} = 4 mA: A ₂ -A ₃₁ , D ₀ -D ₃₁ . I _{OL} = 5 mA: all others	1,2,3			0.45	V
Output high voltage	V _{OH}	I _{OH} = -1 mA: A ₂ -A ₃₁ , D ₀ -D ₃₁ . I _{OH} = -0.9 mA: all others	1,2,3		2.4		V
Input leakage current	I _{LI}	All inputs except: <u>TR011</u> - <u>TRQ23</u> , EOP, TOUT2/TRQ3 DREQ4, 0 < V _{IN} < V _{CC}	1,2,3		-15	+15	μA
Input leakage current	I _{LI1}	Inputs: <u>TR011</u> - <u>TRQ23</u> EOP, TOUT2/TRQ3, DREQ4 0 < V _{IN} < V _{CC} 2/	1,2,3			325	μA
Output leakage current	I _{LO}	0 < V _{OUT} < V _{CC}	1,2,3		-15	+15	μA
Supply current	I _{CC}	CLK2 = 32 MHz	1,2,3	01		240	mA
		CLK2 = 40 MHz 3/		02		248	
		CLK2 = 50 Mhz 3/		03		375	
Input capacitance	C _I	f = 1 MHz See 4.3.1c	4	A11		12	pF
CLK2 input capacitance	C _{CLK}		4	A11		20	pF
Functional tests		4.75 V ≤ V _{CC} ≤ 5.25 V See 4.3.1d	7,8	A11			

See footnotes at end of table.

STANDARD
MICROCIRCUIT DRAWING
DEFENSE ELECTRONICS SUPPLY CENTER
DAYTON, OHIO 45444

SIZE
A

5962-89593

REVISION LEVEL
D

SHEET
4

TABLE I. Electrical performance characteristics - Continued.

Test	Symbol	Conditions -55°C ≤ T _C ≤ +125°C V _{CC} = 5 V ±5% unless otherwise specified	Group A subgroups	Device types	Limits		Unit
					Min	Max	
Operating frequency	f _{MAX}	See figure 4	9,10,11	01	4	16	MHz
				02	4	20	
CLK2 period time	t ₁		9,10,11	01	31.25	125	ns
				02	25	125	
				03	20	125	
CLK2 high time	t _{2a}	Measured at 2.0 V See figure 4	9,10,11	01	9		ns
				02	8		
				03	7		
CLK2 high time <u>1/</u>	t _{2b}	Measured at V _{CC} -0.8 V See figure 4	9,10,11	01	5		ns
				02	5		
				03	4		
CLK2 low time	t _{3a}	Measured at 2.0 V See figure 4	9,10,11	01	9		ns
				02	8		
				03	7		
CLK2 low time <u>1/</u>	t _{3b}	Measured at 0.8 V See figure 4	9,10,11	01	7		ns
				02	6		
				03	4		
CLK2 fall time <u>1/</u>	t ₄	Measured from V _{CC} -0.8 V to 0.8 V, see figure 4	9,10,11	01		8	ns
				02		8	
				03		7	
CLK2 rise time <u>1/</u>	t ₅	Measured from 0.8 V to V _{CC} -0.8 V, see figure 4	9,10,11	01		8	ns
				02		8	
				03		7	
A ₂ -A ₃₁ , \overline{BE}_0 - \overline{BE}_3 , EDACK ₀ -EDACK ₂ valid delay	t ₆	See figure 4	9,10,11	01	4	36	ns
				02	4	30	
				03	4	20	
A ₂ -A ₃₁ , \overline{BE}_0 - \overline{BE}_3 , float delay <u>1/</u>	t ₇		9,10,11	01	4	40	ns
				02	4	32	
A ₂ -A ₃₁ , \overline{BE}_0 - \overline{BE}_3 , setup times	t ₈		9,10,11	A11	6		ns
A ₂ -A ₃₁ , \overline{BE}_0 - \overline{BE}_3 , hold time	t ₉		9,10,11	A11	4		ns
W/R, M/T \overline{O} , D/ \overline{C} valid delay	t ₁₀		9,10,11	01	6	33	ns
				02	6	28	
				03	4	20	
W/R, M/T \overline{O} , D/ \overline{C} float <u>1/</u> delay	t ₁₁		9,10,11	01	4	35	ns
				02	4	30	
				03	4	29	
W/R, M/T \overline{O} , D/ \overline{C} setup	t ₁₂		9,10,11	A11	6		ns

See footnotes at end of table.

STANDARD
MICROCIRCUIT DRAWING
DEFENSE ELECTRONICS SUPPLY CENTER
DAYTON, OHIO 45444

SIZE
A

REVISION LEVEL
D

5962-89593

SHEET
5

TABLE I. Electrical performance characteristics - Continued.

Test	Symbol	Conditions -55°C ≤ T _C ≤ +125°C V _{CC} = 5 V ±5% unless otherwise specified	Group A subgroups	Device types	Limits		Unit
					Min	Max	
W/R, M/I \bar{O} , D/C hold time	t ₁₃	See figure 4	9,10,11	All	4		ns
\overline{ADS} valid delay	t ₁₄		01	6	33	ns	
			02	6	28		
			03	4	19		
\overline{ADS} float delay $\frac{1}{2}$	t ₁₅		01	4	35	ns	
			02	4	30		
			03	4	29		
ADS setup time	t ₁₆		01	21		ns	
			02	15			
			03	12			
\overline{ADS} hold time	t ₁₇		9,10,11	All	4		ns
Slave mode D ₀ -D ₃₁ read	t ₁₈		01	3	46	ns	
			02	4	46		
			03	4	31		
Slave mode D ₀ -D ₃₁ read float delay $\frac{1}{2}$	t ₁₉		01	6	35	ns	
			02	6	29		
			03	6	21		
Slave mode D ₀ -D ₃₁ write setup time	t ₂₀		01	31		ns	
			02	29			
			03	20			
Slave mode D ₀ -D ₃₁ write hold time	t ₂₁		01	26		ns	
			02	26			
			03	20			
Master mode D ₀ -D ₃₁ write valid delay	t ₂₂		01	4	48	ns	
			02	4	38		
			03	6	27		
Master mode D ₀ -D ₃₁ write float delay $\frac{1}{2}$	t ₂₃		01	4	35	ns	
			02	4	27		
		03	4	19			
Master mode D ₀ -D ₃₁ read setup time	t ₂₄	01	11		ns		
		02	11				
		03	7				
Master mode D ₀ -D ₃₁ read hold time	t ₂₅	01	6		ns		
		02	6				
		03	4				
READY setup time	t ₂₆	01	21		ns		
		02	12				
		03	9				
READY hold time	t ₂₇	9,10,11	All	4		ns	
WSCO-WSC1 setup time	t ₂₈	9,10,11	All	6		ns	

See footnotes at end of table.

STANDARD
MICROCIRCUIT DRAWING
DEFENSE ELECTRONICS SUPPLY CENTER
DAYTON, OHIO 45444

SIZE
A

REVISION LEVEL
D

5962-89593

SHEET
6

TABLE I. Electrical performance characteristics - Continued.

Test	Symbol	Conditions -55°C ≤ T _C ≤ +125°C V _{CC} = 5 V ±5% unless otherwise specified	Group A subgroups	Device types	Limits		Unit
					Min	Max	
WSCO-WSC1 hold time	t ₂₉	See figure 4	9,10,11	01	21		ns
				02	21		
				03	15		
RESET hold time	t ₃₀		9,10,11	01	4		ns
				02	4		
				03	4		
RESET setup time	t ₃₁		9,10,11	01	13		ns
				02	12		
				03	9		
$\overline{\text{READY0}}$ valid delay	t ₃₂		9,10,11	01	4	31	ns
				02	4	28	
				03	3	21	
CPU reset delay	t ₃₃		9,10,11	01	2	18	ns
				02	2	16	
				03	2	14	
Hold delay	t ₃₄		9,10,11	01	5	33	ns
				02	5	30	
				03	4	22	
HLDA setup time	t ₃₅		9,10,11	01	21		ns
				02	17		
				03	17		
HLDA hold time	t ₃₆		9,10,11	01	6		ns
				02	6		
				03	4		
$\overline{\text{EOP}}$ setup time	t _{37a}		9,10,11	01	21		ns
				02	17		
				03	13		
$\overline{\text{EOP}}$ hold time	t _{38a}		9,10,11	All	4		ns
$\overline{\text{EOP}}$ setup time	t _{37b}		9,10,11	01	11		ns
				02	11		
				03	10		
$\overline{\text{EOP}}$ hold time	t _{38b}		9,10,11	01	11		ns
				02	11		
				03	10		
$\overline{\text{EOP}}$ valid delay	t ₃₉		9,10,11	01	5	38	ns
				02	5	30	
				03	4	21	
$\overline{\text{EOP}}$ float delay <u>1/</u>	t ₄₀		9,10,11	01	5	40	ns
				02	5	32	
				03	4	21	

See footnotes at end of table.

STANDARD MICROCIRCUIT DRAWING DEFENSE ELECTRONICS SUPPLY CENTER DAYTON, OHIO 45444	SIZE A		5962-89593
		REVISION LEVEL D	SHEET 7

TABLE I. Electrical performance characteristics - Continued.

Test	Symbol	Conditions -55°C ≤ T _C ≤ +125°C V _{CC} = 5 V ±5% unless otherwise specified	Group A subgroups	Device types	Limits		Unit	
					Min	Max		
DREQ setup time	t _{41a}	Synchronous See figure 4	9,10,11	01	21		ns	
				02	19			
				03	17			
DREQ hold time	t _{42a}		9,10,11	A11	4		ns	
DREQ setup time	t _{41b}		Synchronous See figure 4	9,10,11	01	11		ns
					02	11		
		03			4			
DREQ hold time	t _{42b}	9,10,11		A11	11		ns	
					02	11		
					03	10		
INT valid delay	t ₄₃	See figure 4	9,10,11	A11		500	ns	
\overline{NA} setup time	t ₄₄	See figure 4	9,10,11	01	11		ns	
				02	10			
				03	7			
\overline{NA} hold time	t ₄₅		9,10,11	A11	15		ns	
					02	15		
					03	8		
CLKIN frequency	t ₄₆		9,10,11	A11	0 ^{1/}	10	MHz	
CLKIN high time	t ₄₇	Measured at 2.0 V See figure 4	9,10,11	A11	30		ns	
CLKIN low time	t ₄₈	Measured at 0.8 V See figure 4	9,10,11	A11	50		ns	
CLKIN rise time ^{1/}	t ₄₉	Measured from 0.8 V to V _{CC} -0.8 V, see figure 4	9,10,11	A11		10	ns	
CLKIN fall time ^{1/}	t ₅₀	Measured from V _{CC} -0.8 V to 0.8 V	9,10,11	A11		10	ns	
TOUT1/ \overline{REF} valid from CLK2	t ₅₁	See figure 4 ^{4/}	9,10,11	01	4	36	ns	
				02	4	30		
				03	4	20		
TOUT1/ \overline{REF} valid from CLKIN	t ₅₂		9,10,11	A11	3	93	ns	
					02	3	93	
					03	3	90	
TOUT2 valid delay	t ₅₃		9,10,11	A11	3	93	ns	
					02	3	93	
					03	3	90	
TOUT2 float delay	t ₅₄		9,10,11	A11	3	40	ns	
					02	3	40	
					03	3	37	
TOUT3 valid delay	t ₅₅		9,10,11	A11	3	93	ns	
					02	3	93	
					03	3	90	

See footnotes at end of table.

STANDARD MICROCIRCUIT DRAWING DEFENSE ELECTRONICS SUPPLY CENTER DAYTON, OHIO 45444	SIZE A		5962-89593
		REVISION LEVEL D	SHEET 8

TABLE I. Electrical performance characteristics - Continued.

- 1/ Guaranteed to the limit specified herein, if not tested.
- 2/ These pins should not be left floating.
- 3/ I_{CC} is specified with inputs driven to CMOS levels, and outputs driving CMOS loads. I_{CC} may be higher if inputs are driven to TTL levels, or if outputs are driving TTL loads.
- 4/ All outputs loaded to 50 pf.

STANDARD MICROCIRCUIT DRAWING DEFENSE ELECTRONICS SUPPLY CENTER DAYTON, OHIO 45444	SIZE A		5962-89593
		REVISION LEVEL D	SHEET 9

Case Y

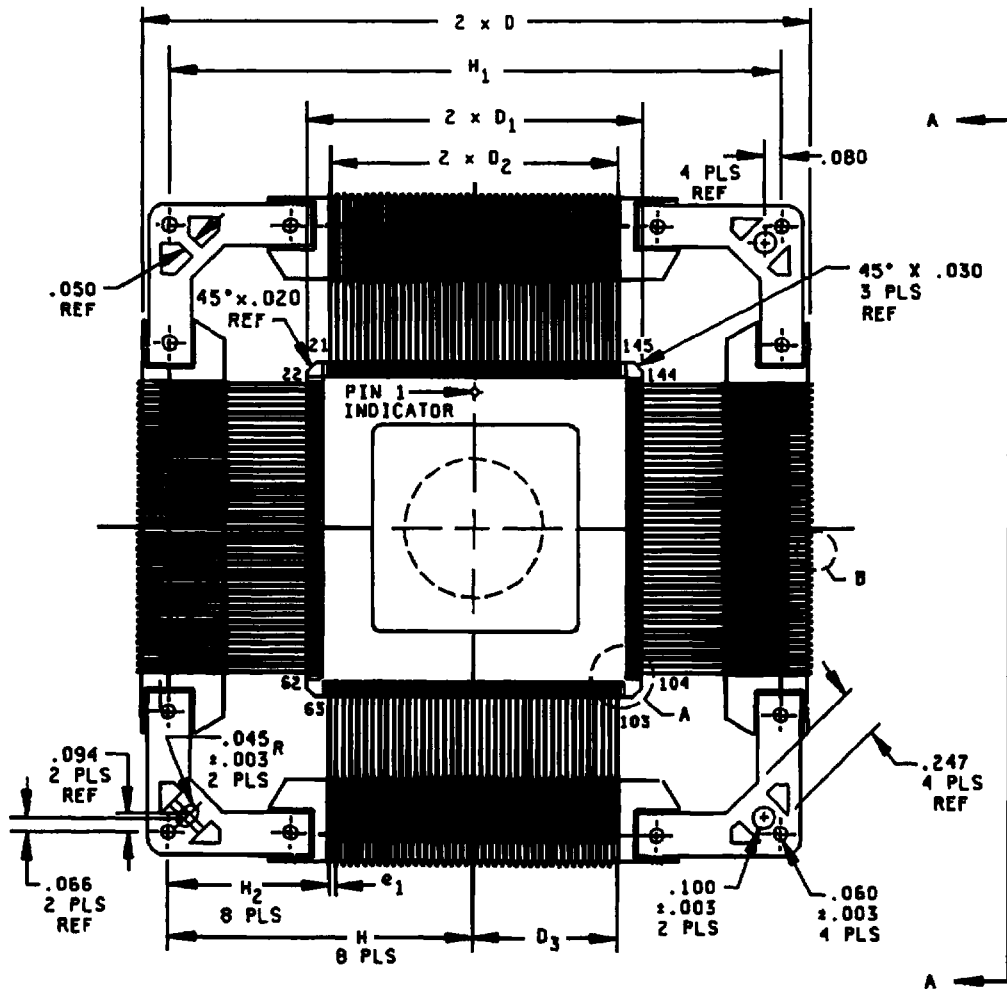

FIGURE 1. Case outline.

STANDARD
MICROCIRCUIT DRAWING
DEFENSE ELECTRONICS SUPPLY CENTER
DAYTON, OHIO 45444

SIZE
A

5962-89593

REVISION LEVEL
D

SHEET
10

Case Y

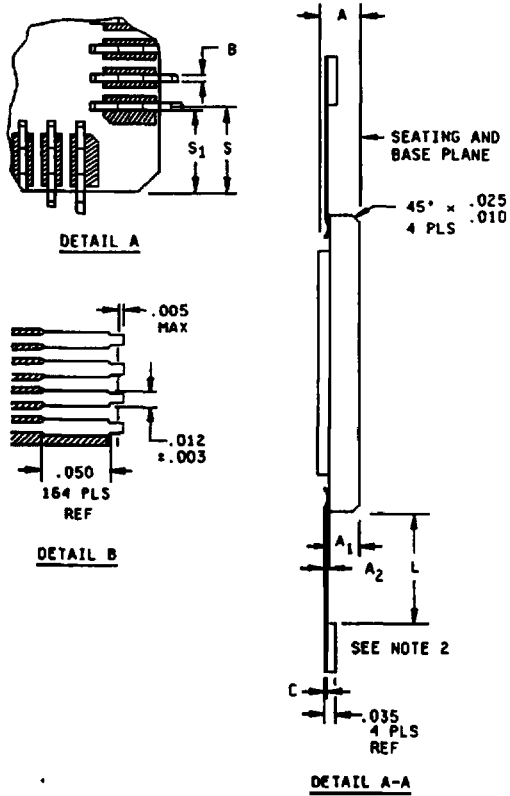

Symbol	Inches		Millimeters	
	Min	Max	Min	Max
A	.088	.115	2.23	2.92
A ₁	.078	.094	1.98	2.39
A ₂	.006	.012	0.15	0.30
B	.007	.010	0.18	0.25
C	.004	.006	0.10	0.15
D	2.480	2.520	63.00	64.01
D ₁	1.120	1.140	28.45	28.96
D ₂	1.00	BASIC	25.40	BASIC
D ₃	.500	BASIC	12.70	BASIC
e ₁	.023	.027	0.58	0.69
H	1.150	BASIC	29.21	BASIC
H ₁	2.30	BASIC	58.42	BASIC
H ₂	.650	BASIC	16.51	BASIC
L	.365	.395	9.27	10.03
N	164 TERMINALS			
S	.060	.080	1.52	2.03
S ₁	.060	.076	1.52	1.93

NOTES:

1. Dimensions are in inches.
2. Metric equivalents are given for general information only.
3. Symbols B and C dimensions shall be increased by .002 inch when solder coat is added.

FIGURE 1. Case outline - Continued.

STANDARD MICROCIRCUIT DRAWING DEFENSE ELECTRONICS SUPPLY CENTER DAYTON, OHIO 45444	SIZE A		5962-89593
		REVISION LEVEL D	SHEET 11

Case Y

Pin	Signal	Pin	Signal	Pin	Signal	Pin	Signal
1	A ₄	28	A ₂₂	55	D ₁₃	82	D ₁
2	V _{CC}	29	V _{SS}	56	D ₅	83	D ₂₄
3	V _{SS}	30	V _{CC}	57	D ₂₈	84	D ₁₆
4	A ₅	31	A ₂₃	58	D ₂₀	85	D ₈
5	A ₆	32	A ₂₄	59	D ₁₂	86	D ₀
6	A ₇	33	A ₂₅	60	V _{CC}	87	V _{SS}
7	A ₈	34	A ₂₆	61	V _{SS}	88	V _{CC}
8	A ₉	35	A ₂₇	62	NC	89	READY ₀
9	V _{CC}	36	A ₂₈	63	NC	90	TOUT1/REF
10	V _{SS}	37	A ₂₉	64	V _{CC}	91	HOLD
11	A ₁₀	38	A ₃₀	65	D ₄	92	M/ $\overline{T0}$
12	A ₁₁	39	A ₃₁	66	D ₂₇	93	V _{SS}
13	A ₁₂	40	NC	67	D ₁₉	94	V _{CC}
14	A ₁₃	41	D ₃₁	68	D ₁₁	95	NC
15	V _{CC}	42	D ₂₃	69	D ₃	96	NC
16	V _{SS}	43	D ₁₅	70	D ₂₆	97	W/ \overline{R}
17	A ₁₄	44	D ₇	71	D ₁₈	98	D/ \overline{C}
18	A ₁₅	45	D ₃₀	72	D ₁₀	99	TOUT3
19	A ₁₆	46	V _{SS}	73	D ₂	100	TOUT2/TRQ3
20	A ₁₇	47	V _{CC}	74	V _{SS}	101	CPURST
21	NC	48	D ₂₂	75	V _{CC}	102	NC
22	NC	49	D ₁₄	76	D ₂₅	103	V _{CC}
23	V _{CC}	50	D ₆	77	D ₁₇	104	V _{SS}
24	A ₁₈	51	V _{SS}	78	D ₉	105	V _{CC}
25	A ₁₉	52	V _{CC}	79	V _{SS}	106	NC
26	A ₂₀	53	D ₂₉	80	CLK2	107	V _{SS}
27	A ₂₁	54	D ₂₁	81	V _{SS}	108	V _{CC}

FIGURE 2. Terminal connections.

STANDARD
MICROCIRCUIT DRAWING
DEFENSE ELECTRONICS SUPPLY CENTER
DAYTON, OHIO 45444

SIZE
A

5962-89593

REVISION LEVEL
D

SHEET
12

Case Y

Pin	Signal	Pin	Signal	Pin	Signal	Pin	Signal
109	READY	123	TRQ18	137	NA	151	EDACK1
110	RESET	124	TRQ19	138	DREQ6	152	EDACK2
111	WSC1	125	TRQ20	139	DREQ7	153	V _{CC}
112	WSC0	126	TRQ21	140	V _{CC}	154	V _{SS}
113	V _{SS}	127	TRQ22	141	V _{SS}	155	EOP
114	CLKIN	128	TRQ23	142	NC	156	ADS
115	V _{CC}	129	V _{CC}	143	NC	157	BE ₀
116	TRQ11	130	V _{SS}	144	NC	158	BE ₁
117	TRQ12	131	DREQ0	145	NC	159	BE ₂
118	TRQ13	132	DREQ1	146	HLDA	160	BE ₃
119	TRQ14	133	DREQ2	147	INT	161	V _{CC}
120	TRQ15	134	DREQ3	148	NC	162	V _{SS}
121	TRQ16	135	DREQ4/TRQ9	149	NC	163	A ₂
122	TRQ17	136	DREQ5	150	EDACK0	164	A ₃

FIGURE 2. Terminal connections - Continued.

STANDARD MICROCIRCUIT DRAWING DEFENSE ELECTRONICS SUPPLY CENTER DAYTON, OHIO 45444	SIZE A		5962-89593
		REVISION LEVEL D	SHEET 13

Pin/signal	Pin/signal	Pin/signal	Pin/signal
A7	A ₃₁	A8	D ₃₁
C7	A ₃₀	B9	D ₃₀
B7	A ₂₉	A11	D ₂₉
A6	A ₂₈	C11	D ₂₈
B6	A ₂₇	D12	D ₂₇
C6	A ₂₆	E13	D ₂₆
A5	A ₂₅	F14	D ₂₅
B5	A ₂₄	J13	D ₂₄
C5	A ₂₃	B8	D ₂₃
B4	A ₂₂	C9	D ₂₂
B3	A ₂₁	B11	D ₂₁
C4	A ₂₀	B13	D ₂₀
B2	A ₁₉	D13	D ₁₉
C3	A ₁₈	E14	D ₁₈
C2	A ₁₇	G12	D ₁₇
D3	A ₁₆	H13	D ₁₆
D2	A ₁₅	C8	D ₁₅
E3	A ₁₄	A10	D ₁₄
E2	A ₁₃	C10	D ₁₃
E1	A ₁₂	C12	D ₁₂
F3	A ₁₁	D14	D ₁₁
F2	A ₁₀	F12	D ₁₀
F1	A ₉	G13	D ₉
G1	A ₈	K14	D ₈
G2	A ₇	A9	D ₇
G3	A ₆	B10	D ₆
H1	A ₅	B12	D ₅
H2	A ₄	C13	D ₄
J1	A ₃	E12	D ₃
H3	A ₂	F13	D ₂
J2	<u>BE₃</u>	H14	D ₁
J3	<u>BE₂</u>	J14	D ₀
K1	<u>BE₁</u>	N12	RESET
L1	<u>BE₀</u>	M12	CPURST
		P12	V _{CC}
		M14	V _{CC}
		P1	V _{CC}
		P2	V _{CC}
		P14	V _{CC}
		D1	V _{CC}
		C14	V _{CC}
		B1	V _{CC}
		A2	V _{CC}
		A4	V _{CC}
		A12	V _{CC}
		A14	V _{CC}
		G14	CLK2
		L12	D/C
		K12	W/R
		L13	M/I/O
		K2	ADS
		N4	NA
		J12	HOLD
		M3	HLDA
		M6	DREQ0
		P5	DREQ1
		N5	DREQ2
		P4	DREQ3
		M5	DREQ4/IRQ9
		P3	DREQ5
		M4	DREQ6
		N3	DREQ7
		K3	EOP
		L3	EDACK0
		M1	EDACK1
		L2	EDACK2
		L14	V _{SS}
		A1	V _{SS}
		P13	V _{SS}
		N1	V _{SS}
		N2	V _{SS}
		C1	V _{SS}
		A3	V _{SS}
		B14	V _{SS}
		A13	V _{SS}
		N14	V _{SS}
		P6	IRQ23
		N6	IRQ22
		M7	IRQ21
		N7	IRQ20
		P7	IRQ19
		P8	IRQ18
		M8	IRQ17
		N8	IRQ16
		P9	IRQ15
		N9	IRQ14
		M9	IRQ13
		N10	IRQ12
		P10	IRQ11
		M2	INT
		N11	CLKIN
		K13	TOUT1/REF
		N13	TOUT2/IRQ3
		M13	TOUT3
		M11	READY
		H12	READY0
		P11	WSCO
		M10	WSC1

FIGURE 2. Terminal connections - Continued.

STANDARD
MICROCIRCUIT DRAWING
DEFENSE ELECTRONICS SUPPLY CENTER
DAYTON, OHIO 45444

SIZE
A

5962-89593

REVISION LEVEL
D

SHEET
14

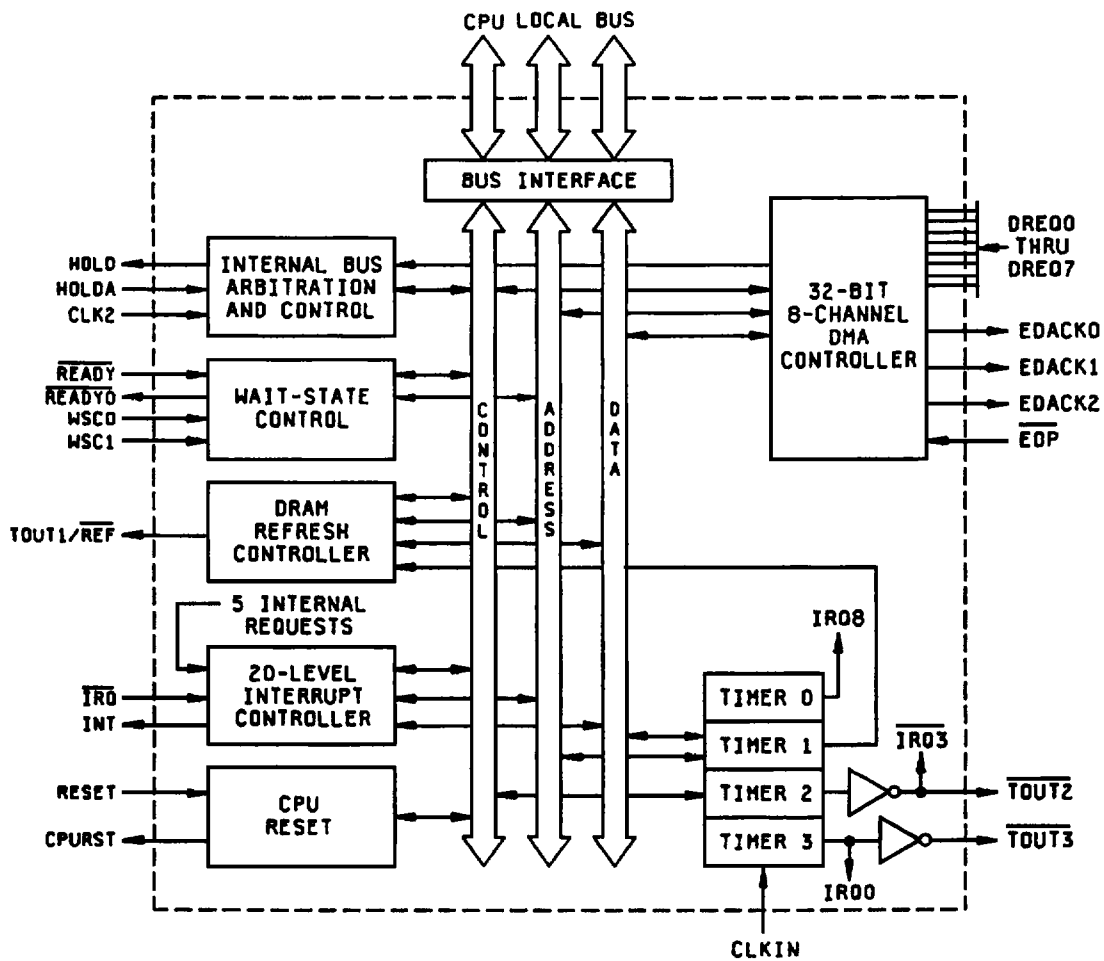
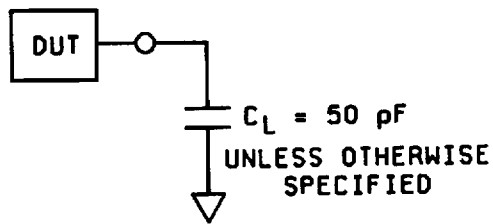
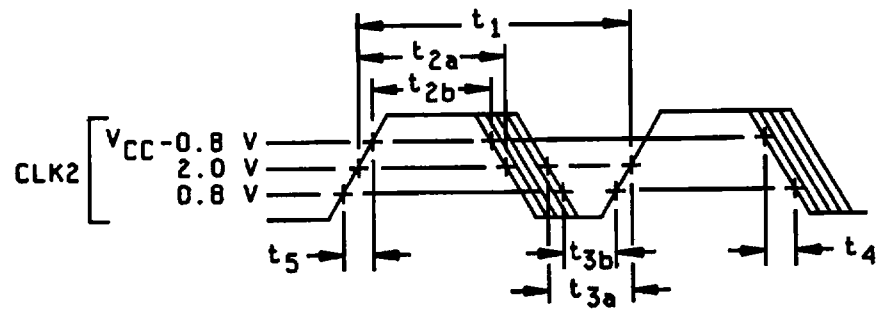

FIGURE 3. Functional block diagram.

STANDARD MICROCIRCUIT DRAWING DEFENSE ELECTRONICS SUPPLY CENTER DAYTON, OHIO 45444	SIZE A		5962-89593
		REVISION LEVEL D	SHEET 15



AC TEST CIRCUIT



CLK2 TIMING

NOTE: All ac timings are tested at 1.5 V threshold, unless otherwise specified.

FIGURE 4. AC test circuit and timing waveforms.

STANDARD MICROCIRCUIT DRAWING DEFENSE ELECTRONICS SUPPLY CENTER DAYTON, OHIO 45444	SIZE A		5962-89593
		REVISION LEVEL D	SHEET 16

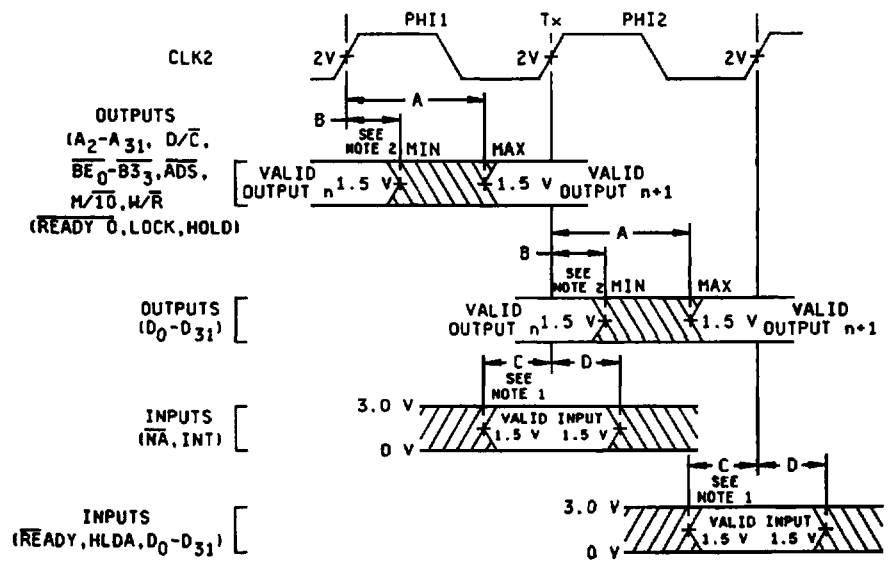

LEGEND:
 A - Maximum output delay specification.
 B - Minimum output delay specification.
 C - Minimum input setup specification.
 D - Minimum input hold specification.

NOTES:
 1. Input waveforms have $t_r \leq 2$ ns from 0.8 V to 2 V.
 2. Under rated loading (120 pF): output t_r , t_f is typically ≤ 4 ns from 0.8 V to 2 V.
 3. All timing measurements are tested at 1.5 V, unless otherwise specified.

Drive levels and measurements points for ac specification.

FIGURE 4. AC test circuit and timing waveforms - Continued.

STANDARD MICROCIRCUIT DRAWING DEFENSE ELECTRONICS SUPPLY CENTER DAYTON, OHIO 45444	SIZE A		5962-89593
		REVISION LEVEL D	SHEET 17

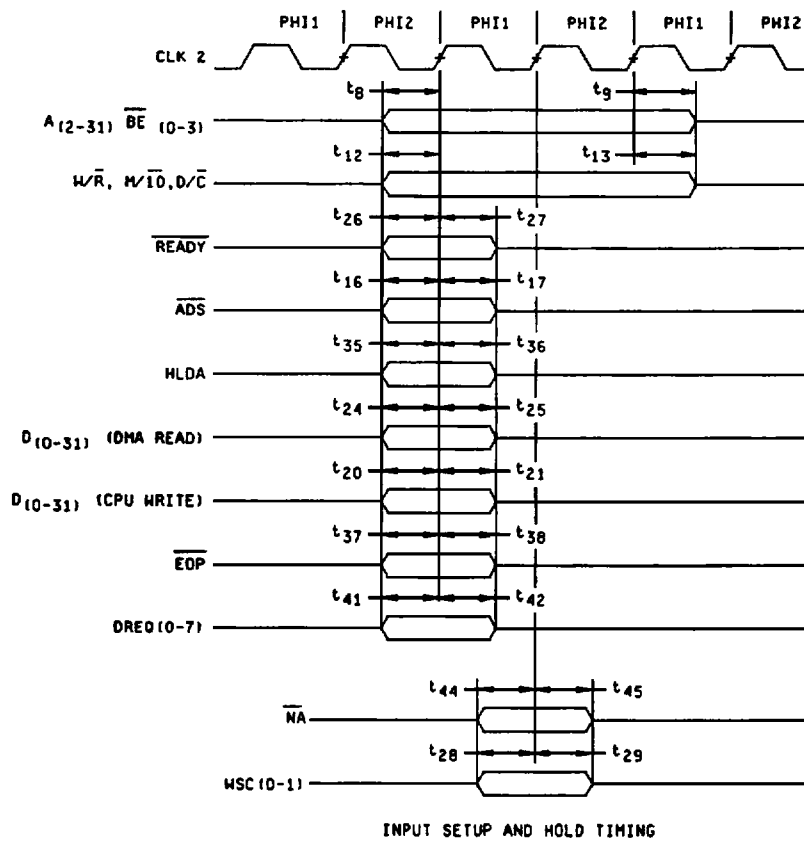

NOTE: All timing measurements are tested at 1.5 V, unless otherwise specified.

FIGURE 4. AC test circuit and timing waveforms - Continued.

STANDARD
MICROCIRCUIT DRAWING
DEFENSE ELECTRONICS SUPPLY CENTER
DAYTON, OHIO 45444

SIZE
A

5962-89593

REVISION LEVEL
D

SHEET
18

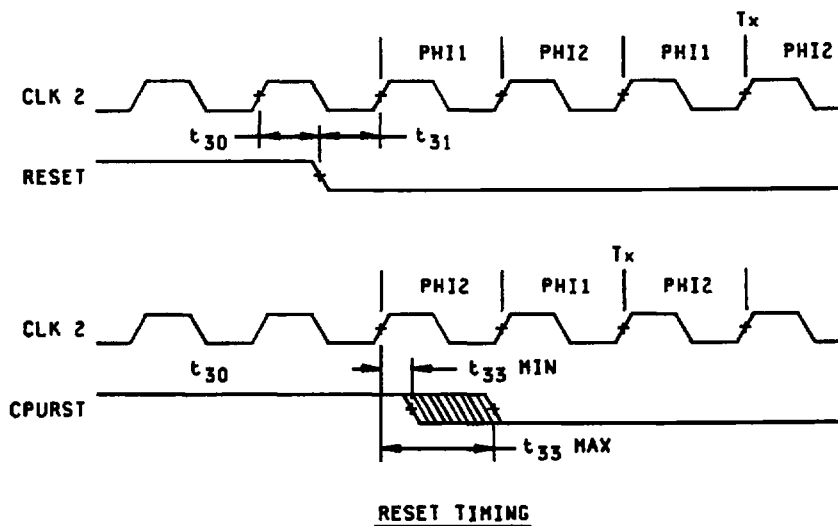

NOTE: All timing measurements are tested at 1.5 V, unless otherwise specified.

FIGURE 4. AC test circuit and timing waveforms - Continued.

STANDARD MICROCIRCUIT DRAWING DEFENSE ELECTRONICS SUPPLY CENTER DAYTON, OHIO 45444	SIZE A		5962-89593
		REVISION LEVEL D	SHEET 19

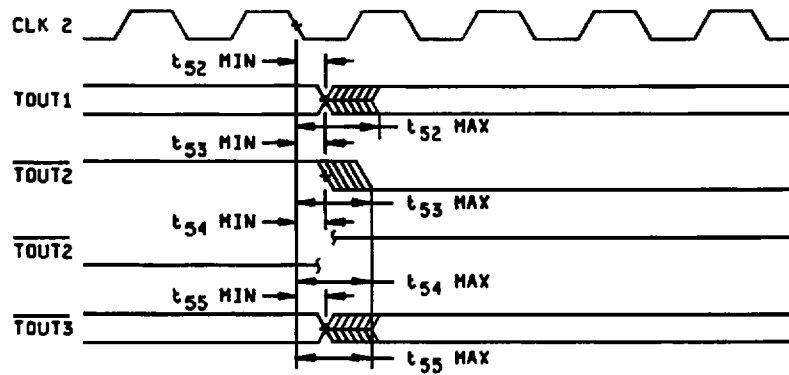

TIMER OUTPUT DELAYS

NOTE: All timing measurements are tested at 1.5 V, unless otherwise specified.

FIGURE 4. AC test circuit and timing waveforms - Continued.

STANDARD MICROCIRCUIT DRAWING DEFENSE ELECTRONICS SUPPLY CENTER DAYTON, OHIO 45444	SIZE A		5962-89593
		REVISION LEVEL D	SHEET 20

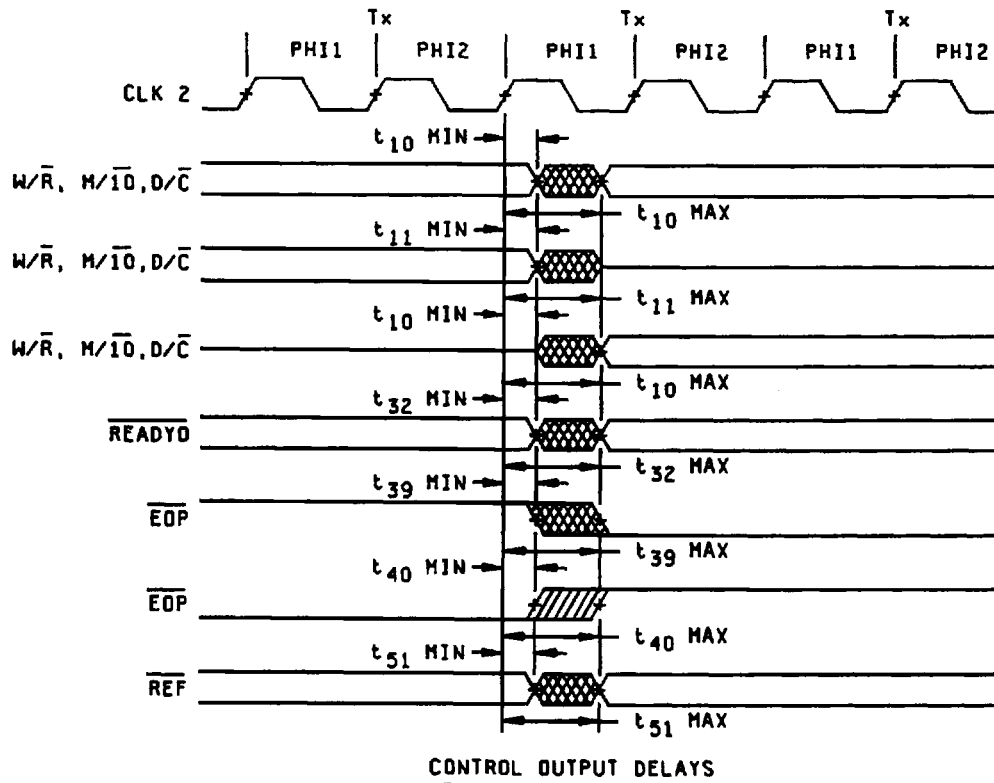

NOTE: All timing measurements are tested at 1.5 V, unless otherwise specified.

FIGURE 4. AC test circuit and timing waveforms - Continued.

STANDARD MICROCIRCUIT DRAWING DEFENSE ELECTRONICS SUPPLY CENTER DAYTON, OHIO 45444	SIZE A		5962-89593
		REVISION LEVEL D	SHEET 21

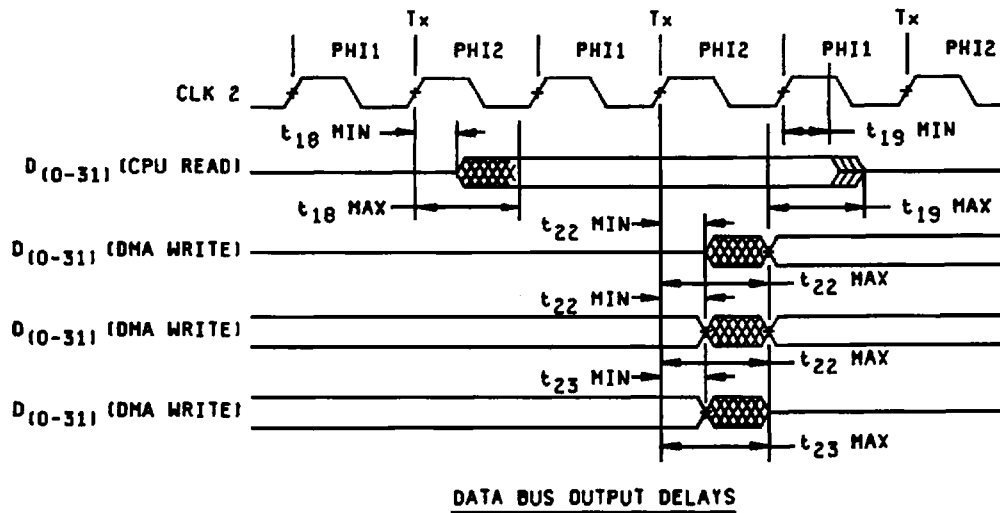

NOTE: All timing measurements are tested at 1.5 V, unless otherwise specified.

FIGURE 4. AC test circuit and timing waveforms - Continued.

STANDARD MICROCIRCUIT DRAWING DEFENSE ELECTRONICS SUPPLY CENTER DAYTON, OHIO 45444	SIZE A		5962-89593
		REVISION LEVEL D	SHEET 22

4. QUALITY ASSURANCE PROVISIONS

4.1 Sampling and inspection. Sampling and inspection procedures shall be in accordance with MIL-STD-883 (see 3.1 herein).

4.2 Screening. Screening shall be in accordance with method 5004 of MIL-STD-883, and shall be conducted on all devices prior to quality conformance inspection. The following additional criteria shall apply:

- a. Burn-in test, method 1015 of MIL-STD-883.
 - (1) Test condition C or D. The test circuit shall be maintained by the manufacturer under document revision level control and shall be made available to the preparing or acquiring activity upon request. The test circuit shall specify the inputs, outputs, biases, and power dissipation, as applicable, in accordance with the intent specified in test method 1015 of MIL-STD-883.
 - (2) $T_A = +125^\circ\text{C}$, minimum.
- b. Interim and final electrical test parameters shall be as specified in table II herein, except interim electrical parameter tests prior to burn-in are optional at the discretion of the manufacturer.

TABLE II. Electrical test requirements.

MIL-STD-883 test requirements	Subgroups (in accordance with method 5005, table I)
Interim electrical parameters (method 5004)	
Final electrical test parameters (method 5004)	1*, 2, 3, 7*, 8, 9, 10, 11
Group A test requirements (method 5005)	1*, 2, 3, 7*, 8, 9, 10, 11
Groups C and D end-point electrical parameters (method 5005)	2, 8a, 10

* PDA applies to subgroup 1.

4.3 Quality conformance inspection. Quality conformance inspection shall be in accordance with method 5005 of MIL-STD-883 including groups A, B, C, and D inspections. The following additional criteria shall apply.

4.3.1 Group A inspection.

- a. Tests shall be as specified in table II herein.
- b. Subgroups 5 and 6 in table I, method 5005 of MIL-STD-883 shall be omitted.
- c. Subgroup 4 (C_{IN} and C_{CLK} measurement) shall be measured only for the initial test and after process or design changes which may affect input capacitance.
- d. Subgroups 7 and 8 shall include verification of the functionality of the device. These tests form a part of the manufacturer's test tape and shall be maintained and available from the approved source of supply..

STANDARD MICROCIRCUIT DRAWING DEFENSE ELECTRONICS SUPPLY CENTER DAYTON, OHIO 45444	SIZE A		5962-89593
		REVISION LEVEL D	SHEET 23

4.3.2 Groups C and D inspections.

- a. End-point electrical parameters shall be as specified in table II herein.
- b. Steady-state life test conditions, method 1005 of MIL-STD-883.
 - (1) Test condition C or D. The test circuit shall be maintained by the manufacturer under document revision level control and shall be made available to the preparing or acquiring activity upon request. The test circuit shall specify the inputs, outputs, biases, and power dissipation, as applicable, in accordance with the intent specified in test method 1005 of MIL-STD-883.
 - (2) $T_A = +125^{\circ}\text{C}$, minimum.
 - (3) Test duration: 1,000 hours, except as permitted by method 1005 of MIL-STD-883.

5. PACKAGING

5.1 Packaging requirements. The requirements for packaging shall be in accordance with MIL-STD-883 (see 3.1 herein).

6. NOTES

6.1 Intended use. Microcircuits conforming to this drawing are intended for use for Government microcircuit applications (original equipment), design applications, and logistics purposes.

6.2 Replaceability. Microcircuits covered by this drawing will replace the same generic device covered by a contractor-prepared specification or drawing.

6.3 Configuration control of SMD's. All proposed changes to existing SMD's will be coordinated with the users of record for the individual documents. This coordination will be accomplished in accordance with MIL-STD-973 using DD Form 1692, Engineering Change Proposal .

6.4 Record of users. Military and industrial users shall inform Defense Electronics Supply Center when a system application requires configuration control and the applicable SMD. DESC will maintain a record of users and this list will be used for coordination and distribution of changes to the drawings. Users of drawings covering microelectronics devices (FSC 5962) should contact DESC-EC, telephone (513) 296-6047.

6.5 Comments. Comments on this drawing should be directed to DESC-EC, Dayton, Ohio 45444-5270, or telephone (513) 296-5377.

6.6 Approved sources of supply. Approved sources of supply are listed in MIL-BUL-103. The vendors listed in MIL-BUL-103 have agreed to this drawing and a certificate of compliance (see 3.6 herein) has been submitted to and accepted by DESC-EC.

6.7 Pin descriptions.

Pin name	I/O	Description
A_0-A_{31}	I/O	Address bus. This is the 32-bit address bus. The addresses are doubleword memory and I/O addresses. These are three-state signals which are active only during master mode. The address lines should be connected directly to the CPU's local bus.
D_0-D_{31}	I/O	Data bus. This is the 32-bit data bus. These pins are active outputs during interrupt acknowledges, during slave accesses, and when the device is in the master mode.
CLK2	I	Processor clock. This pin must be connected to CLK2. The device monitors the phase of this clock in order to remain synchronized with the CPU. This clock drives all of the internal synchronous circuitry.
D/\bar{C}	I/O	Data/control. D/\bar{C} is used to distinguish between CPU control cycles and DMA or CPU data access cycles. It is active as an output only in the master mode.

STANDARD MICROCIRCUIT DRAWING DEFENSE ELECTRONICS SUPPLY CENTER DAYTON, OHIO 45444	SIZE A		5962-89593
		REVISION LEVEL D	SHEET 24

Pin name	I/O	Description - Continued.
\overline{BE}_0	I/O	Byte enable 0. \overline{BE}_0 active indicates that data bits D_0-D_7 are being accessed or are valid. It is connected directly to the CPU's \overline{BE}_0 . The byte enable signals are active outputs when the device is in the master mode.
\overline{BE}_1	I/O	Byte enable 1. \overline{BE}_1 active indicates that data bits D_8-D_{15} are being accessed or are valid. It is connected directly to the CPU's \overline{BE}_1 . The byte enable signals are active only when the device is in the master mode.
\overline{BE}_2	I/O	Byte enable 2. \overline{BE}_2 active indicates that data bits $D_{16}-D_{23}$ are being accessed or are valid. It is connected directly to the CPU's \overline{BE}_2 . The byte enable signals are active only when the device is in the master mode.
\overline{BE}_3	I/O	Byte enable 3. \overline{BE}_3 active indicates that data bits $D_{24}-D_{31}$ are being accessed or are valid. The byte enable signals are active only when the device is in the master mode. This pin should be connected directly to the CPU's \overline{BE}_3 . This pin is used for factory testing and must be low during reset. The CPU drivers \overline{BE}_3 low during reset.
HOLD	0	Hold request. This is an active-high signal to the CPU to request control of the system bus. When control is granted, the CPU activates the hold acknowledge signal (HLDA).
HLDA	1	Hold acknowledge. This input signals tells the DMA controller that the CPU has relinquished control of the system bus to the DMA controller.

STANDARD MICROCIRCUIT DRAWING DEFENSE ELECTRONICS SUPPLY CENTER DAYTON, OHIO 45444	SIZE A		5962-89593
		REVISION LEVEL D	SHEET 25

STANDARDIZED MILITARY DRAWING SOURCE APPROVAL BULLETIN

DATE: 95-09-26

Approved sources of supply for SMD 5962-89593 are listed below for immediate acquisition only and shall be added to MIL-BUL-103 during the next revision. MIL-BUL-103 will be revised to include the addition or deletion of sources. The vendors listed below have agreed to this drawing and a certificate of compliance has been submitted to and accepted by DESC-EC. This bulletin is superseded by the next dated revision of MIL-BUL-103.

Standardized military drawing PIN	Vendor CAGE number	Vendor similar PIN <u>1/</u>
5962-8959301YX	34649	MQ82380-16/Q
5962-8959301ZX	34649	MG82380-16/Q
5962-8959302YX	34649	MQ82380-20/Q
5962-8959302ZX	34649	MG82380-20/Q
5962-8959303YX	34649	MQ82380-25/Q
5962-8959303ZX	34649	MG82380-25/Q

1/ Caution. Do not use this number for item acquisition. Items acquired to this number may not satisfy the performance requirements of this drawing.

Vendor CAGE number

34649

Vendor name and address

Intel Corporation
 3065 Bowers Ave.
 Santa Clara, CA 95051
 Point of contact: 5800 W. Chandler Blvd.
 Chandler, AZ 85226

The information contained herein is disseminated for convenience only and the Government assumes no liability whatsoever for any inaccuracies in this information bulletin.