



001-0028

**2 dBi Dipole Antenna with RP SMA
863-870 MHz**

ELECTRICAL SPECIFICATIONS

Operating Frequency (MHz)	863-870
VSWR	≤ 2.0:1
Gain (dBi)	2.0
Nominal Impedance (Ohms)	50
Polarization	Linear vertical

MECHANICAL & ENVIRONMENTAL SPECIFICATIONS

Dimensions - mm (inches)	197.0 x 13.0 (7.76 x 0.51)
Ingress Protection	IP-65
Weight - g (ounces)	27.0 (0.95)
Antenna Color	Black
Operating Temperature - °C (°F)	-20 to +65°C (-4 to +149°F)
Storage Temperature - °C (°F)	-30 to +70°C (-22 to +158°F)

ORDERING INFORMATION

PART NUMBER	DESCRIPTION
001-0028	868 MHz dipole antenna with reverse polarity SMA connector
080-0001	U.FL to SMA bulkhead cable, 1.13 mm diameter, 105.0 mm length

MECHANICAL DRAWING

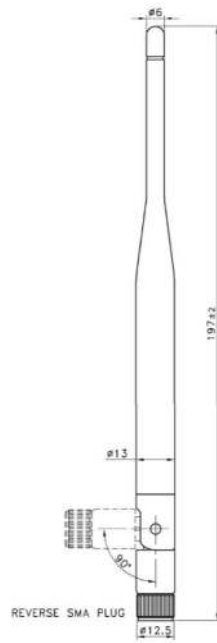

Figure 1: Physical dimensions

TEST SETUP

Antenna measurements such as VSWR were measured with an Agilent E5071C vector network analyzer. Radiation patterns were measured with a CMT planar 804/1 vector network analyzer in a Howland Company 3100 chamber equivalent. Phase center is nine inches above the Phi positioner.

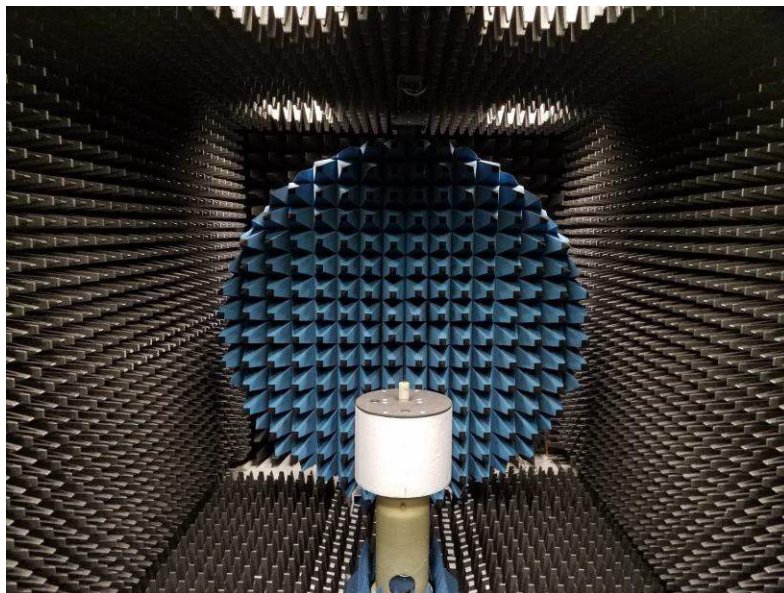

Figure 2: Antenna chamber

TYPICAL ANTENNA REFLECTION PERFORMANCE

Straight Position

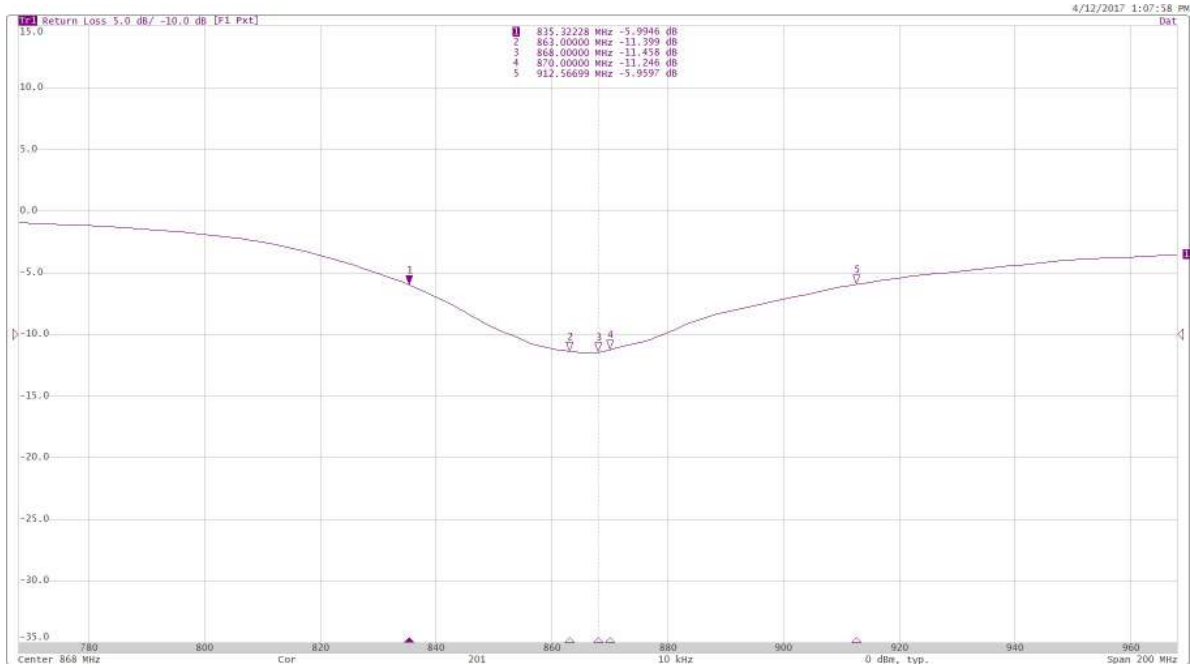

Figure 3: Typical antenna reflection performance

Bent Position

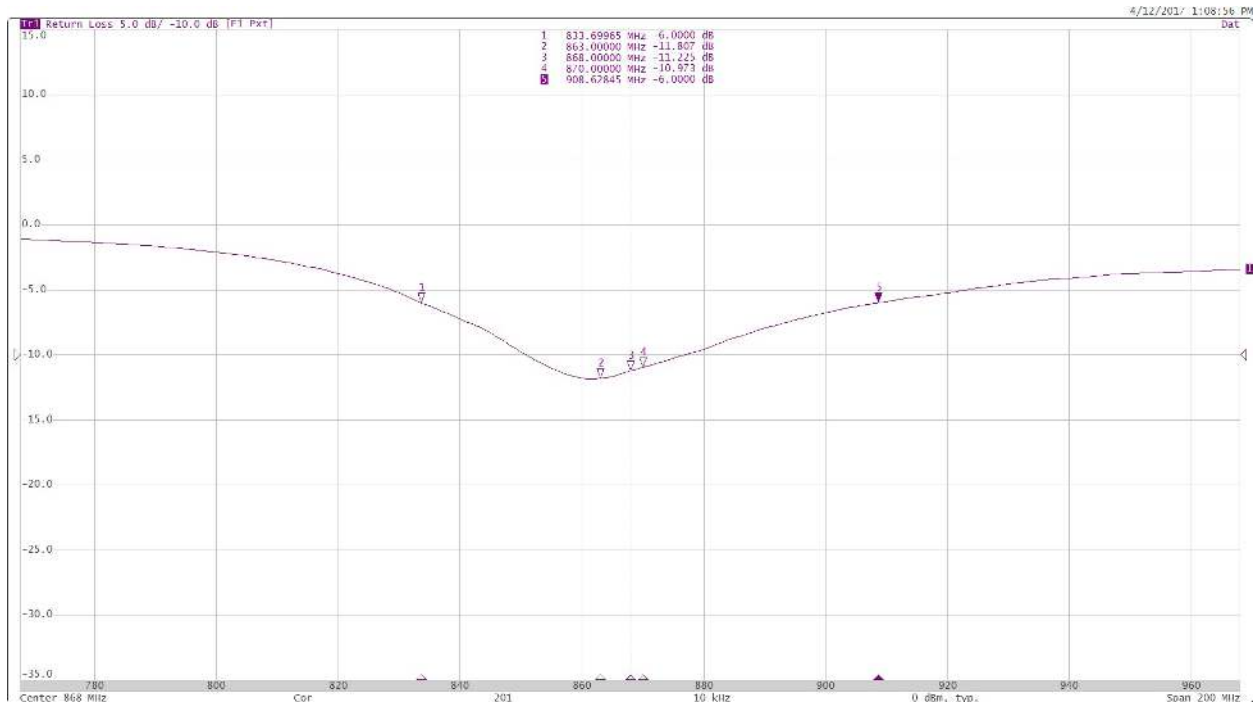

Figure 4: Typical antenna reflection performance

TYPICAL ANTENNA RADITION PERFORMANCE

Antenna Measurement Setup

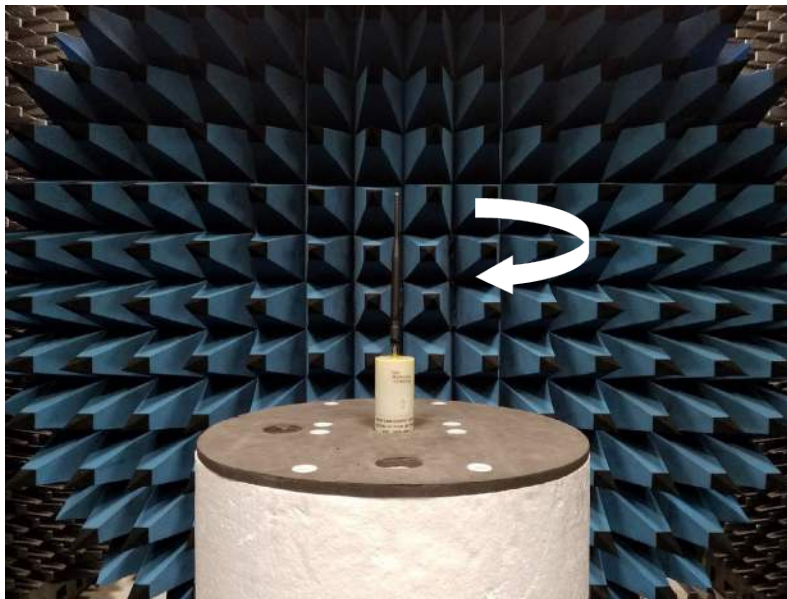

Figure 5: Straight position test setup

Straight Position

Azimuth Conical Cuts at 868 MHz:

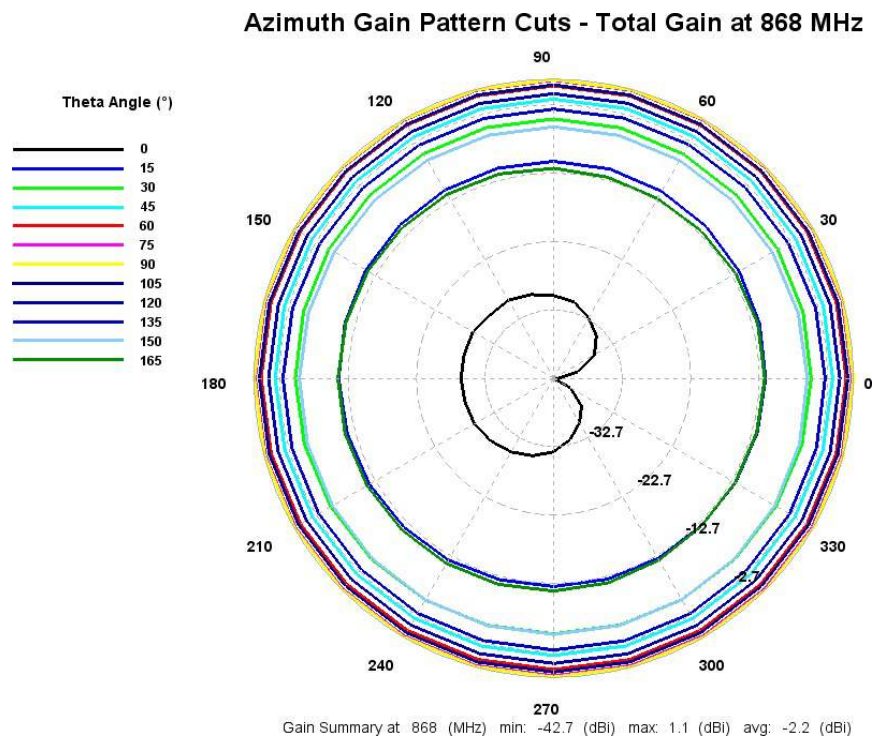

Figure 6: Total gain pattern

3D Plots at 868 MHz:

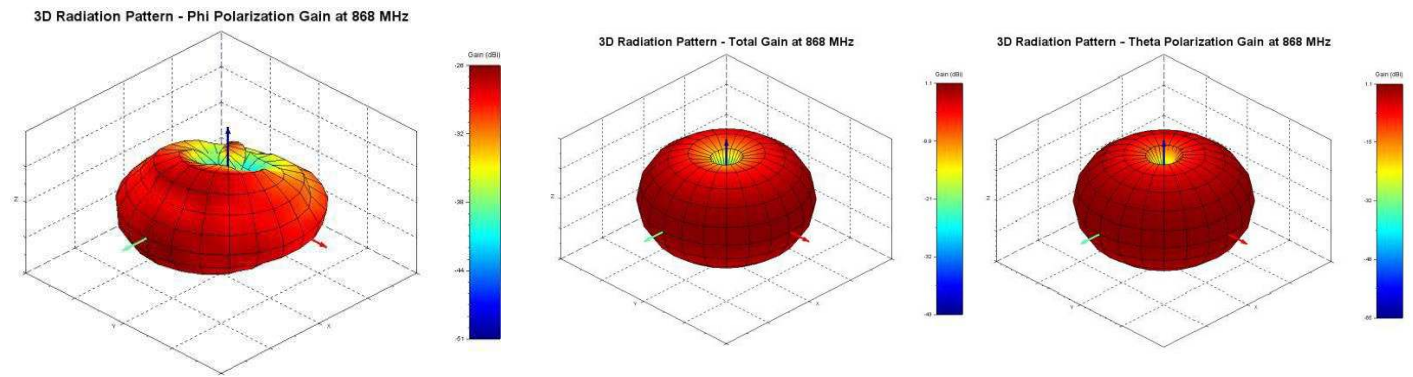

Figure 7: Phi, theta, and total gain plots

ANTENNA MEASUREMENT SETUP



Figure 8: Bent position test setup

Bent Position

Azimuth Conical Cuts at 868 MHz:

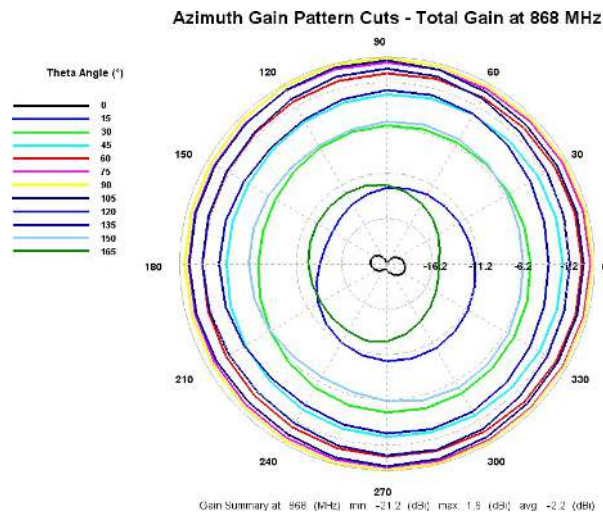

Figure 9: Total gain pattern

3D Plots at 868 MHz:

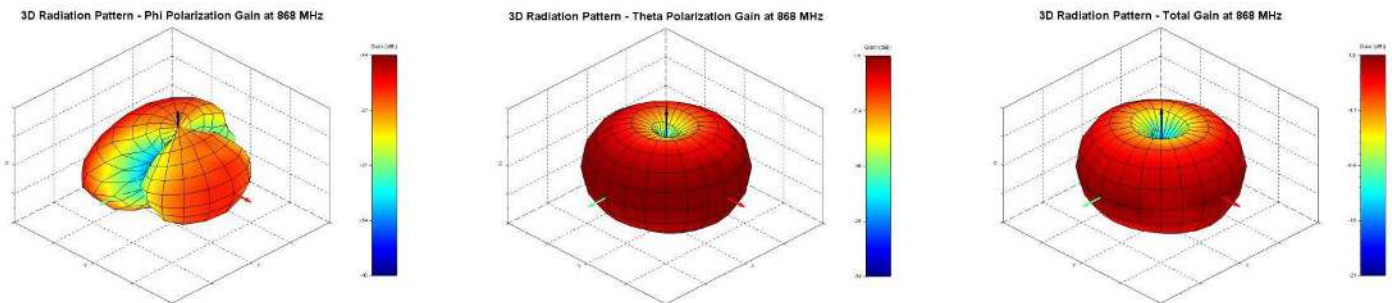

Figure 10: Phi, theta, and total gain plots

te.com

TE, and TE connectivity (logo) are trademarks owned or licensed by the TE Connectivity Ltd. family of companies. All other logos, products and/or company names referred to herein might be trademarks of their respective owners.

The information given herein, including drawings, illustrations and schematics which are intended for illustration purposes only, is believed to be reliable. However, TE Connectivity makes no warranties as to its accuracy or completeness and disclaims any liability in connection with its use. TE Connectivity's obligations shall only be as set forth in TE Connectivity's Standard Terms and Conditions of Sale for this product and in no case will TE Connectivity be liable for any incidental, indirect or consequential damages arising out of the sale, resale, use or misuse of the product. Users of TE Connectivity products should make their own evaluation to determine the suitability of each such product for the specific application.

TE Connectivity warrants to the original end user customer of its products that its products are free from defects in material and workmanship. Subject to conditions and limitations TE Connectivity will, at its option, either repair or replace any part of its products that prove defective because of improper workmanship or materials. This limited warranty is in force for the useful lifetime of the original end product into which the TE Connectivity product is installed. Useful lifetime of the original end product may vary but is not warranted to exceed one (1) year from the original date of the end product purchase.

©2022 TE Connectivity. All Rights Reserved.

08/22 Original

TE TECHNICAL SUPPORT CENTER

USA:	+1 (800) 522-6752
Canada:	+1 (905) 475-6222
Mexico:	+52 (0) 55-1106-0800
Latin/S. America:	+54 (0) 11-4733-2200
Germany:	+49 (0) 6251-133-1999
UK:	+44 (0) 800-267666
France:	+33 (0) 1-3420-8686
Netherlands:	+31 (0) 73-6246-999
China:	+86 (0) 400-820-6015