



MAX8668 Evaluation Kit

General Description

The MAX8668 evaluation kit (EV kit) is a fully assembled and tested printed-circuit board (PCB) for evaluating the MAX8668 dual step-down DC-DC converter with dual LDOs. The MAX8668 EV kit operates from a 2.6V to 5.5V supply and provides a 600mA step-down output, a 1200mA step-down output, and two 300mA LDO outputs. The EV kit comes with the MAX8668ETEA+ installed, providing two adjustable step-down outputs and two 2.8V preset LDO outputs. The adjustable output voltages for the two step-down converters are set to 1.2V (OUT1) and 1.8V (OUT2), and can be adjusted from 0.6V to 3.3V by changing resistors on the board. The MAX8668 EV kit can also be used to evaluate any version of the MAX8667 (preset step-down/preset LDO) or MAX8668 (adjustable step-down/preset LDO). Refer to the *Selector Guide* in the MAX8667/MAX8668 IC data sheet for a list of available preset output voltages.

Features

- ◆ Tiny, Thin QFN, 3mm x 3mm IC Package
- ◆ Individual Enables
- ◆ Dual Step-Down Converters
 - 600mA Guaranteed Current on OUT1
 - 1200mA Guaranteed Current on OUT2
 - Output Voltage from 0.6V to 3.3V
 - Ultra-Fast Line and Load Transients
 - Low 25µA Supply Current Each
- ◆ Dual 300mA LDOs
- ◆ Fully Assembled and Tested

Ordering Information

PART	TYPE
MAX8668EVKIT+	EV Kit

+Denotes lead-free and RoHS-compliant.

Component List

DESIGNATION	QTY	DESCRIPTION
C1	1	0.01µF ±10%, 25V X7R ceramic capacitor (0402) TDK C1005X7R1E103K Murata GRM155R71E103KA
C2	1	10µF ±10%, 6.3V X5R ceramic capacitor (0805) TDK C2012X5R0J106K
C3, C7	2	4.7µF ±10%, 6.3V X5R ceramic capacitors (0603) TDK C1608X5R0J475K
C4	1	68pF, 50V C0G ceramic capacitor (0402) TDK C1005C0G1H680J Murata GRM1555C1H680J
C5	1	27pF, 50V C0G ceramic capacitor (0402) TDK C1005C0G1H270J Murata GRM1555C1H270J
C6	1	2.2µF ±10%, 6.3V X5R ceramic capacitor (0603) TDK C1608X5R0J225K

DESIGNATION	QTY	DESCRIPTION
C8, C9	2	4.7µF ±10%, 10V X5R ceramic capacitors (0805) TDK C2012X5R1A475K Murata GRM21BR61A475K
C10	1	56pF, 50V C0G ceramic capacitor (0402) TDK C1005C0G1H560J Murata GRM1555C1H560J
JU1–JU5	5	3-pin headers
L1	1	2.2µH inductor Murata LQH32CN2R2M53
L2	1	2.3µH inductor Sumida CDRH4D22-2R3
R1, R6	2	200kΩ ±1% resistors (0402)
R2, R4	2	100kΩ ±1% resistors (0402)
R3, R5	2	402kΩ ±1% resistors (0402)
TP1, TP2	0	Not installed, test points
U1	1	MAX8668ETEA+ (16-pin Thin QFN, 3mm x 3mm)
—	5	Shunts, 2 positions
—	1	PCB: MAX8668 Evaluation Kit+

Evaluates: MAX8667/MAX8668

MAX8668 Evaluation Kit

Quick Start

Recommended Equipment

Before beginning, the following equipment is needed:

- 2.6V to 5.5V power supply capable of delivering 2.5A
- Voltmeter
- Loads (resistors or electronic loads)

Procedure

The MAX8668 EV kit is fully assembled and tested. Follow the steps below to verify board operation.

Caution: Do not turn on the power supply until all connections are completed.

- 1) Place a shunt across pins 2-3 of jumpers JU1–JU4 on the EV kit to enable all outputs.
- 2) Place a shunt across pins 2-3 of jumper JU5 for single-supply operation.
- 3) Set the power-supply voltage to 3.6V. Turn the power supply off. Do not turn on the power supply until all connections are completed.
- 4) Connect the positive power-supply lead to the EV kit pad labeled IN12. Connect the power-supply ground to one of the EV kit pads labeled GND.
- 5) Connect loads between the EV kit pads labeled OUT_ and GND.
- 6) Turn on the power supply.
- 7) Connect a voltmeter across the EV kit OUT_ pads and GND to verify that the output voltage matches the voltages listed in Table 1.

Table 1. Default Output Voltages and Maximum Load Current

OUTPUT	CONVERTER TYPE	DEFAULT VOLTAGE (V)	MAXIMUM LOAD CURRENT (mA)
OUT1	Step-down	1.2	600
OUT2	Step-down	1.8	1200
OUT3	LDO	2.8	300
OUT4	LDO	2.8	300

Detailed Description

Enable Inputs

The MAX8668 provides individual enable inputs for each regulator. On the MAX8668 EV kit, they are controlled by jumpers JU1–JU4. Place a shunt on pins 1-2 of the corresponding jumper to shut down the regulator, or place the shunt on pins 2-3 to enable the regulator.

LDO Input Supply

The MAX8668 allows the LDO regulators to be powered from a supply range of 1.7V to V_{IN12} . To power the LDOs from a separate external supply, remove the shunt from JU5 and connect the supply from IN34 to GND. To power the LDOs from OUT2, place a shunt across pins 1-2 of JU5. To use the step-down input supply (IN12) for the LDOs, place a shunt across pins 2-3 of JU5.

Adjusting the Output Voltages

The step-down output voltages for the MAX8668 (OUT1 and OUT2) can be adjusted from 0.6V to 3.3V. This is done by changing the feedback resistors (R1 and R6 for OUT1 or R3 and R5 for OUT2). For optimal performance, the feed-forward capacitor (C4 for OUT1 or C5 for OUT2) may also be changed. Refer to the MAX8667/MAX8668 IC data sheet for detailed information on calculating these component values.

Evaluating Other Versions of the MAX8668

Other versions of the MAX8668 are available with different LDO output voltages. To evaluate one of these parts, carefully remove the MAX8668 from the EV kit board and replace it with the new part.

Evaluating the MAX8667

The MAX8667 has factory-preset output voltages for both the step-down converters and the LDOs. To evaluate the MAX8667, carefully remove the IC from the EV kit board and replace it with the MAX8667. Remove components C4, C5, C10, R1, R2, R3, R4, R5, and R6, and then short the pads of R5 and R6.

Table 2. Jumper Functions

JUMPER	POSITION	FUNCTION
JU1	1-2	Disable OUT1
	2-3	Enable OUT1
JU2	1-2	Disable OUT2
	2-3	Enable OUT2
JU3	1-2	Disable OUT3
	2-3	Enable OUT3
JU4	1-2	Disable OUT4
	2-3	Enable OUT4
JU5	1-2	LDOs are powered from OUT2
	2-3	LDOs are powered from IN12
	Open	LDOs are powered from IN34 (external voltage supply between 1.7V to V_{IN12})

MAX8668 Evaluation Kit

Evaluates: MAX8667/MAX8668

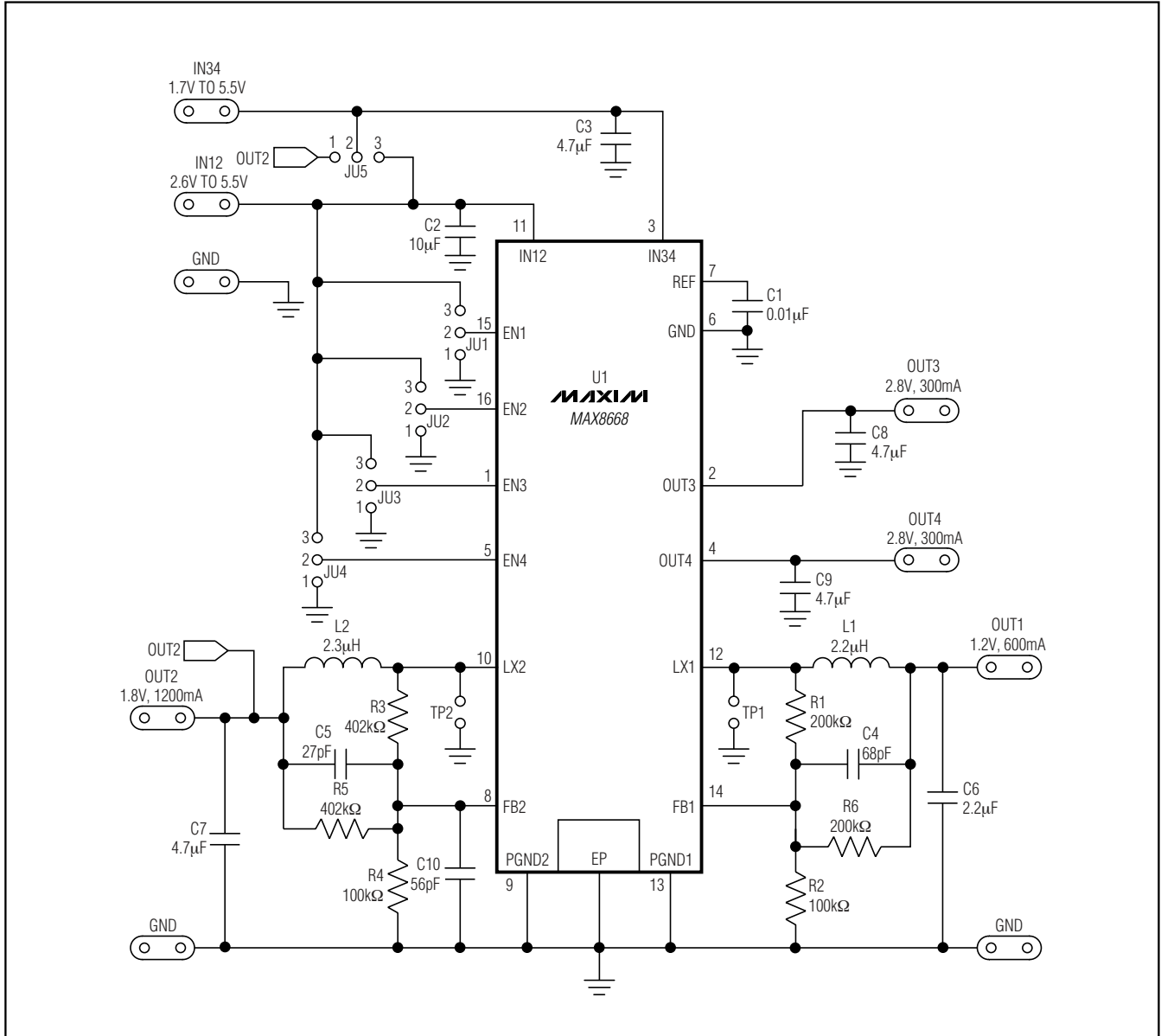

Figure 1. MAX8668 EV Kit Schematic

MAX8668 Evaluation Kit

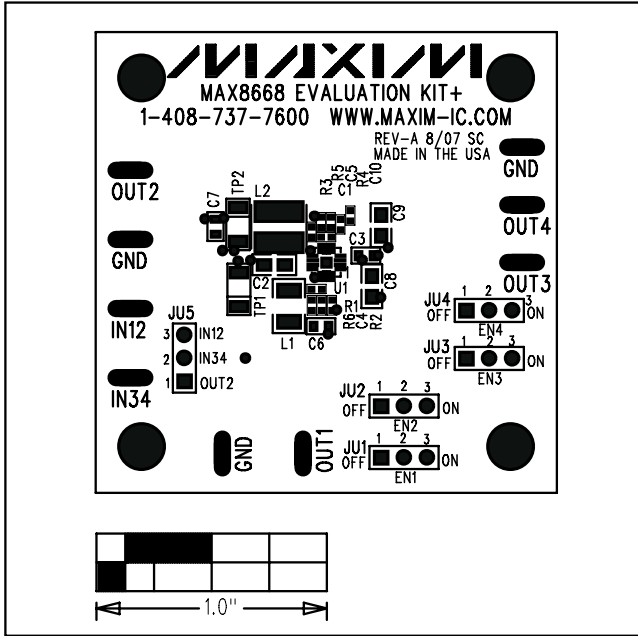

Figure 2. MAX8668 EV Kit Component Placement Guide—Component Side

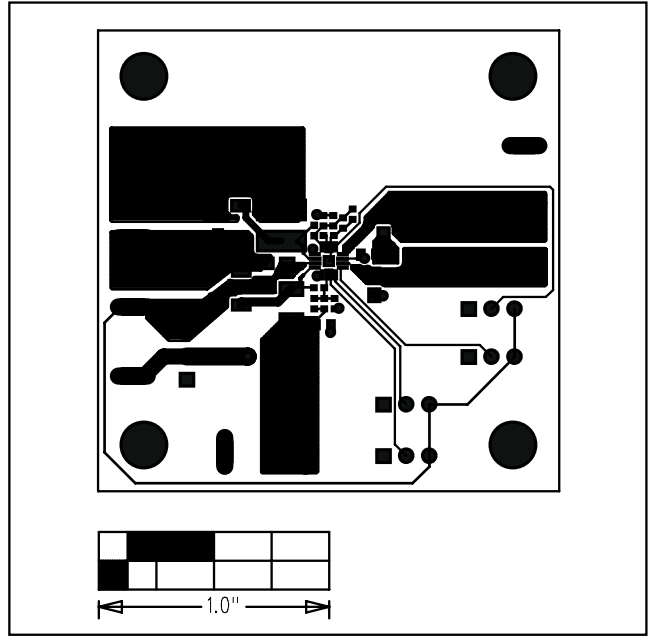

Figure 3. MAX8668 EV Kit PCB Layout—Component Side

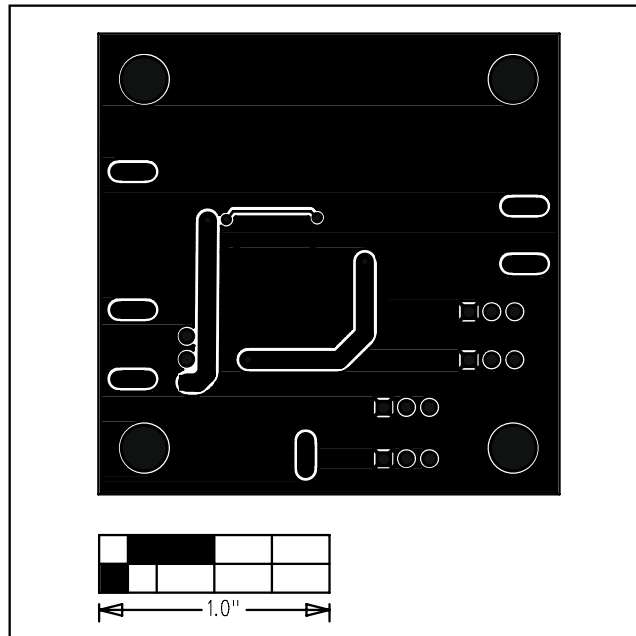

Figure 4. MAX8668 EV Kit PCB Layout—Solder Side

Maxim cannot assume responsibility for use of any circuitry other than circuitry entirely embodied in a Maxim product. No circuit patent licenses are implied. Maxim reserves the right to change the circuitry and specifications without notice at any time.

4 _____ **Maxim Integrated Products, 120 San Gabriel Drive, Sunnyvale, CA 94086 408-737-7600**