

**FEATURES**

**Programmable FastDSP audio processing engine**  
Up to 768 kHz sample rate  
Biquad filters, limiters, volume controls, mixing

**28-bit SigmaDSP audio processing core**  
Visually programmable using [SigmaStudio](#)  
Up to 50 MIPS performance

**Low latency, 24-bit ADCs and DAC**  
96 dB SNR (signal through PGA and ADC with A-weighted filter)  
105 dB combined SNR (signal through DAC and headphone with A-weighted filter)

**Serial port  $f_{\text{SYNC}}$  frequency from 8 kHz to 768 kHz**  
5  $\mu\text{s}$  group delay ( $f_s = 768 \text{ kHz}$ ) analog in to analog out  
2 single-ended analog inputs, configurable as microphone or line inputs  
4 digital microphone inputs  
1 analog differential audio output, configurable as either line output or headphone driver

**PLL supporting any input clock rate from 30 kHz to 27 MHz**  
Full-duplex, 4-channel ASRCs  
16-channel serial audio port supporting I<sup>2</sup>S, left justified, or up to TDM16  
8 interpolators and 8 decimators with flexible routing

**Power supplies**  
Analog AVDD at 1.8 V typical  
Digital I/O IOVDD at 1.1 V to 1.98 V  
Digital DVDD at 0.9 V typical

**Low power (8.030 mW for typical power consumption)**  
I<sup>2</sup>C and SPI control interfaces  
Flexible GPIO  
42-ball, 0.35 mm pitch, 2.695 mm  $\times$  2.320 mm WLCSP

**APPLICATIONS**

Noise cancelling handsets, headsets, and headphones  
Bluetooth ANC handsets, headsets, and headphones  
Personal navigation devices  
Digital still and video cameras  
Musical instrument effect processors  
Multimedia speaker systems  
Smartphones

**GENERAL DESCRIPTION**

The ADAU1788 is a codec with two inputs and one output that incorporates two digital signal processors (DSPs). The path from the analog input to the DSP core to the analog output is optimized for low latency and is ideal for noise cancelling headsets. With the addition of just a few passive components, the ADAU1788 provides a noise cancelling headphone solution.

Note that throughout this data sheet, multifunction pins, such as BCLK\_0/MP1, are referred to either by the entire pin name or by a single function of the pin, for example, BCLK\_0, when only that function is relevant.

**TABLE OF CONTENTS**

Features .....	1	PDM Outputs.....	39
Applications.....	1	ASRCs .....	39
General Description .....	1	Interpolation and Decimation Blocks .....	40
Revision History .....	5	Signal Levels.....	40
Functional Block Diagram .....	6	FastDSP Core .....	41
Specifications.....	7	Instructions .....	41
Analog Performance Specifications .....	7	Filter Precision.....	41
Crystal Amplifier Specifications.....	9	Flags and Conditional Execution.....	41
Digital Input and Output Specifications .....	9	Input Sources .....	41
Power Supply Specifications.....	10	Power and Run Control.....	42
Power-Down Current .....	10	Data Memory.....	42
Typical Power Consumption.....	11	Parameters.....	42
Digital Filters.....	12	Parameter Bank Switching .....	42
Digital Timing Specifications .....	13	Parameter Bank Copying .....	42
Absolute Maximum Ratings.....	17	Parameter Memory Access.....	43
Thermal Resistance .....	17	FastDSP Parameter Safeload .....	43
ESD Caution.....	17	SigmaDSP Core.....	44
Pin Configuration and Function Descriptions.....	18	Signal Processing Details.....	44
Typical Performance Characteristics .....	21	Read/Write Data Formats .....	45
System Block Diagram .....	28	Software Safeload .....	46
Theory of Operation .....	29	FastDSP Safeload .....	46
System Clocking and Power-Up.....	30	Program RAM, Parameter RAM, and Data RAM .....	47
Power-Down Operation and Options .....	30	Program RAM .....	47
Example ADC to DAC Power-up.....	31	Parameter RAM.....	47
DVDD LDO Regulator .....	31	Data RAM .....	47
Clock Initialization.....	31	Power Saving Options.....	48
PLL.....	32	ADC Bias Current Control .....	48
Multichip Phase Synchronization .....	33	DAC Bias Current Control.....	48
Clock Output.....	33	DAC Low Power Modes .....	48
Power Supply Sequencing .....	33	PLL Bypass .....	48
Signal Routing.....	34	SigmaDSP Clock Speed Control.....	49
Input Signal Paths.....	35	Asynchronous Sample Rate Converters Low Power Modes.....	49
Analog Inputs.....	35	Control Port .....	50
Digital Microphone Inputs.....	36	Burst Mode Communication.....	50
ADCs.....	37	Reading and Writing to Memories .....	51
Output Signal Paths.....	38	I <sup>2</sup> C Port .....	51
Analog Outputs.....	38	SPI Port .....	54
DAC.....	38	Multipurpose Pins.....	55

Serial Data Port.....	56	PGA Channel 0 Gain Control MSBs, Mute, Boost, and Slew Register.....	84
Applications Information.....	58	PGA Channel 0 Gain Control LSBs Register.....	84
Power Supply Bypass Capacitors.....	58	PGA Channel 1 Gain Control MSBs, Mute, Boost, and Slew Register.....	85
Layout.....	58	PGA Channel 1 Gain Control LSBs Register.....	85
Grounding.....	58	PGA Slew Rate and Gain Link Register.....	86
PCB Stackup.....	58	Microphone Bias Level and Current Register.....	86
Register Summary.....	59	DMIC Clock Rate Control Register.....	87
Register Details.....	66	Digital Microphone Channel 0 and Channel 1 Rate, Order, Mapping, and Edge Control Register.....	88
Analog Devices Vendor ID Register.....	66	Digital Microphone Channel 2 and Channel 3 Rate, Order, Mapping, and Edge Control Register.....	89
Device ID Registers.....	66	DMIC Volume Options Register.....	90
Revision Code Register.....	66	Digital Microphone Channel Mute Controls Register.....	90
ADC, DAC, and Headphone Power Controls Register.....	67	Digital Microphone Channel 0 Volume Control Register.....	91
PLL, Microphone Bias, and PGA Power Controls Register.....	67	Digital Microphone Channel 1 Volume Control Register.....	92
Digital Microphone Power Controls Register.....	68	Digital Microphone Channel 2 Volume Control Register.....	93
Serial Port, PDM Output, and Digital Microphone Clock Power Controls Register.....	69	Digital Microphone Channel 3 Volume Control Register.....	94
DSP Power Controls Register.....	70	DAC Sample Rate, Filtering, and Power Controls Register.....	95
ASRC Power Controls Register.....	70	DAC Volume Lunk, High-Pass Filter, and Mute Controls Register.....	96
Interpolator Power Controls Register.....	72	DAC Channel 0 Volume Register.....	97
Decimator Power Controls Register.....	73	DAC Channel 0 Routing Register.....	98
State Retention Controls Register.....	74	Headphone Control Register.....	99
Chip Power Control Register.....	75	Fast to Slow Decimator Sample Rates Channel 0 and Channel 1 Register.....	100
Clock Control Register.....	76	Fast to Slow Decimator Sample Rates Channel 2 and Channel 3 Register.....	101
PLL Input Divider Register.....	76	Fast to Slow Decimator Sample Rates Channel 4 and Channel 5 Register.....	101
PLL Feedback Integer Divider (MSBs) Register.....	77	Fast to Slow Decimator Sample Rates Channel 6 and Channel 7 Register.....	102
PLL Feedback Integer Divider (LSBs) Register.....	77	Fast to Slow Decimator Channel 0 Input Routing Register.....	103
PLL Fractional Numerator Value (MSBs) Register.....	77	Fast to Slow Decimator Channel 1 Input Routing Register.....	104
PLL Fractional Numerator Value (LSBs) Register.....	77	Fast to Slow Decimator Channel 2 Input Routing Register.....	105
PLL Fractional Denominator (MSBs) Register.....	78	Fast to Slow Decimator Channel 3 Input Routing Register.....	106
PLL Fractional Denominator (LSBs) Register.....	78	Fast to Slow Decimator Channel 4 Input Routing Register.....	108
PLL Update Register.....	78	Fast to Slow Decimator Channel 5 Input Routing Register.....	109
ADC Sample Rate Control Register.....	79	Fast to Slow Decimator Channel 6 Input Routing Register.....	110
ADC I <sub>BIAS</sub> Controls Register.....	79	Fast to Slow Decimator Channel 7 Input Routing Register.....	112
ADC High-Pass Filter Control Register.....	80		
ADC Mute and Compensation Control Register.....	80		
Analog Input Precharge Time Register.....	81		
ADC Channel Mutes Register.....	82		
ADC Channel 0 Volume Control Register.....	82		
ADC Channel 1 Volume Control Register.....	83		

Slow to Fast Interpolator Sample Rates Channel 0/Channel 1 Register .....	113	FastDSP Modulo N Counter for Lower Rate Conditional Execution Register .....	146
Slow to Fast Interpolator Sample Rates Channel 2/Channel 3 Register .....	114	FastDSP Generic Conditional Execution Registers .....	147
Slow to Fast Interpolator Sample Rates Channel 4/Channel 5 Register .....	115	FastDSP Safeload Address Register .....	148
Slow to Fast Interpolator Sample Rates Channel 6/Channel 7 Register .....	116	FastDSP Safeload Parameter 0 Value Registers .....	148
Slow to Fast Interpolator Channel 0 Input Routing Register .....	117	FastDSP Safeload Parameter 1 Value Registers .....	149
Slow to Fast Interpolator Channel 1 Input Routing Register .....	119	FastDSP Safeload Parameter 2 Value Registers .....	150
Slow to Fast Interpolator Channel 2 Input Routing Register .....	120	FastDSP Safeload Parameter 3 Value Registers .....	151
Slow to Fast Interpolator Channel 3 Input Routing Register .....	122	FastDSP Safeload Parameter 4 Value Registers .....	152
Slow to Fast Interpolator Channel 4 Input Routing Register .....	124	FastDSP Safeload Update Register .....	153
Slow to Fast Interpolator Channel 5 Input Routing Register .....	126	SigmaDSP Frame Rate Source Select Register.....	153
Slow to Fast Interpolator Channel 6 Input Routing Register .....	128	SigmaDSP Run Register .....	154
Slow to Fast Interpolator Channel 7 Input Routing Register .....	130	SigmaDSP Watchdog Controls Register.....	154
Input ASRC Control, Source, and Rate Selection Register .....	132	SigmaDSP Watchdog Value Registers.....	154
Input ASRC Channel 0 and Channel 1 Input Routing Register .....	133	SigmaDSP Modulo Data Memory Start Position Registers.....	155
Input ASRC Channel 2 and Channel 3 Input Routing Register .....	134	SigmaDSP Fixed Frame Rate Divisor Registers .....	156
Output ASRC Control Register .....	135	SigmaDSP Set Interrupts Register.....	156
Output ASRC Channel 0 Input Routing Register .....	136	Multipurpose Pin 0/Pin 1 Mode Select Register .....	157
Output ASRC Channel 1 Input Routing Register .....	137	Multipurpose Pin 2/Pin 3 Mode Select Register .....	158
Output ASRC Channel 2 Input Routing Register .....	139	Multipurpose Pin 4/Pin 5 Mode Select Register .....	159
Output ASRC Channel 3 Input Routing Register .....	140	Multipurpose Pin 6/Pin 7 Mode Select Register .....	160
FastDSP Run Register .....	141	Multipurpose Pin 8/Pin 9 Mode Select Register .....	161
FastDSP Current Bank and Bank Ramping Controls Register .....	142	Multipurpose Pin 10 Mode Select Register .....	162
FastDSP Bank Ramping Stop Point Register .....	143	General-Purpose Input Debounce Control and Master Clock Output Rate Selection Register.....	162
FastDSP Bank Copying Register.....	144	General-Purpose Outputs Control Pin 0 to Pin 7 Register .....	163
FastDSP Frame Rate Source Register.....	145	General-Purpose Outputs Control Pins 8 to Pin 10 Register .....	164
FastDSP Fixed Rate Division MSBs Register .....	145	FSYNC_0 Pin Controls Register .....	165
FastDSP Fixed Rate Division LSBs Register.....	146	BCLK_0 Pin Controls Register.....	166
		SDATAO_0 Pin Control Register.....	166
		SDATAI_0 Pin Controls Register.....	167
		MP3 Pin Controls Register .....	168
		MP4 Pin Controls Register .....	169
		MP5 Pin Controls Register .....	170
		MP6 Pin Controls Register .....	171
		DMIC_CLK0 Pin Controls Register.....	172
		DMIC_CLK1 Pin Controls Register.....	173
		DMIC01 Pin Controls Register .....	174
		DMIC23 Pin Controls Register .....	175

SDA/MISO Pin Controls Register .....	175	Serial Port 0 Output Routing Slot 3 Register.....	199
IRQ Signaling and Clearing Register.....	176	Serial Port 0 Output Routing Slot 4 Register.....	201
IRQ1 Masking Registers.....	177	Serial Port 0 Output Routing Slot 5 Register.....	202
IRQ2 Masking Registers.....	180	Serial Port 0 Output Routing Slot 6 Register.....	204
Chip Resets Register .....	182	Serial Port 0 Output Routing Slot 7 Register.....	205
FastDSP Current Lambda Register .....	183	Serial Port 0 Output Routing Slot 8 Register.....	207
Chip Status 1 Register.....	184	Serial Port 0 Output Routing Slot 9 Register.....	208
Chip Status 2 Register.....	184	Serial Port 0 Output Routing Slot 10 Register .....	210
General-Purpose Input Read 0 to Input Read 7 Register ...	185	Serial Port 0 Output Routing Slot 11 Register.....	211
General-Purpose Input Read 8 to Input Read 10 Register.....	186	Serial Port 0 Output Routing Slot 12 Register .....	213
DSP Status Register .....	186	Serial Port 0 Output Routing Slot 13 Register .....	214
IRQ1 Status 1 Register.....	187	Serial Port 0 Output Routing Slot 14 Register .....	216
IRQ1 Status 2 Register.....	188	Serial Port 0 Output Routing Slot 15 Register .....	217
IRQ1 Status 3 Register.....	189	PDM Sample Rate and Filtering Control Register .....	219
IRQ2 Status 1 Register.....	190	PDM Muting, High-Pass, and Volume Options Register....	220
IRQ2 Status 2 Register.....	191	PDM Output Channel 0 Volume Register.....	221
IRQ2 Status 3 Register.....	192	PDM Output Channel 1 Volume Register.....	222
Serial Port 0 Control 1 Register.....	193	PDM Output Channel 0 Routing Register .....	222
Serial Port 0 Control 2 Register.....	194	PDM Output Channel 1 Routing Register .....	224
Serial Port 0 Output Routing Slot 0 (Left) Register.....	195	Outline Dimensions.....	226
Serial Port 0 Output Routing Slot 1 (Right) Register .....	196	Ordering Guide .....	226
Serial Port 0 Output Routing Slot 2 Register.....	198		

## REVISION HISTORY

8/2019—Revision 0: Initial Version

FUNCTIONAL BLOCK DIAGRAM

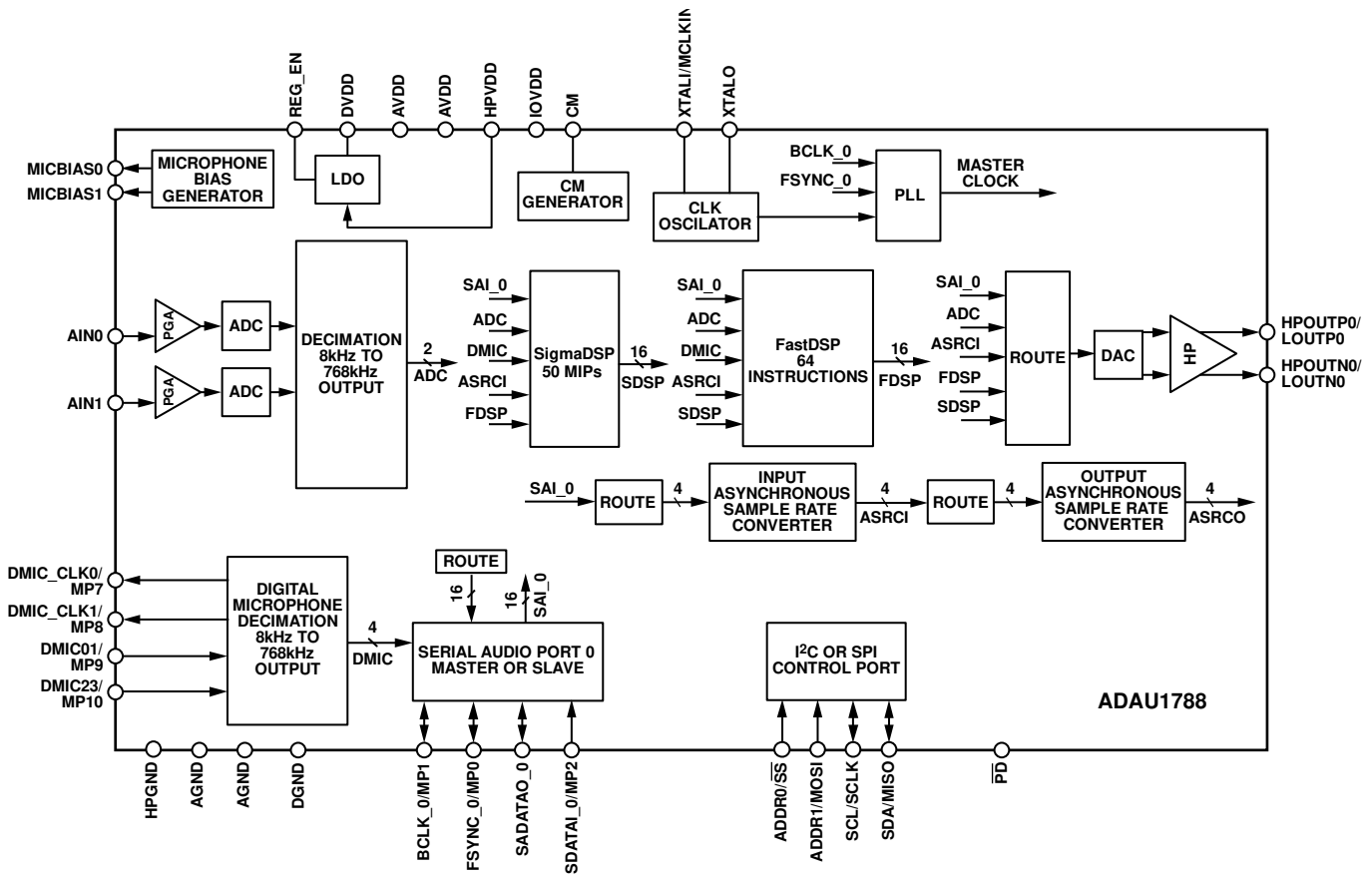

- NOTES
1. SAI\_0 IS THE SERIAL AUDIO INTERFACE 0.
  2. DMIC IS THE DIGITAL MICROPHONE.
  3. ASRCI IS THE INPUT ASYNCHRONOUS SAMPLE RATE CONVERTER.
  4. ASRCO IS THE OUTPUT ASYNCHRONOUS SAMPLE RATE CONVERTER.
  5. FDSP IS FastDSP.
  6. SDSP IS SigmaDSP.

Figure 1.

20534-001

## SPECIFICATIONS

Master clock input = 24.576 MHz, serial input sample rate = 48 kHz, measurement bandwidth = 20 Hz to 20 kHz, word width = 24 bits, ambient temperature ( $T_A$ ) = 25°C, and line output load = 10 k $\Omega$ , unless otherwise noted.

### ANALOG PERFORMANCE SPECIFICATIONS

Supply voltages AVDD = IOVDD = 1.8 V and DVDD = 0.9 V, unless otherwise noted.

Table 1.

Parameter	Test Conditions/Comments	Min	Typ	Max	Unit
<b>ANALOG-TO-DIGITAL CONVERTERS (ADCs)</b>					
ADC Resolution	All ADCs		24		Bits
Digital Gain Step			0.375		dB
Digital Gain Range		-71		+24	dB
<b>INPUT RESISTANCE</b>					
Single-Ended Line Input			14.3		k $\Omega$
Programmable Gain Amplifier (PGA) Inputs	0 dB gain		20.26		k $\Omega$
	32 dB gain		0.97		k $\Omega$
<b>SINGLE-ENDED LINE INPUT</b>					
Full-Scale Input Voltage	PGAx_EN = 0, PGMx_BOOST = 0, PGAx_SLEW_DIS = 1		0.49		V rms
	0 dBFS		1.38		V p-p
Dynamic Range <sup>1</sup>	20 Hz to 20 kHz, -60 dB input				
With A-Weighted Filter (RMS)			97		dB
With Flat 20 Hz to 20 kHz Filter			94		dB
Signal-to-Noise Ratio (SNR) <sup>2</sup>					
With A-Weighted Filter (RMS)			98		dB
With Flat 20 Hz to 20 kHz Filter			96		dB
Interchannel Gain Mismatch			40		mdB
Total Harmonic Distortion + Noise (THD + N) Level	20 Hz to 20 kHz, -1 dB full-scale output				
			-90		dBFS
Offset Error			$\pm 0.1$		mV
Gain Error			$\pm 0.2$		dB
Interchannel Isolation	CM capacitor = 10 $\mu$ F		100		dB
Power Supply Rejection Ratio (PSRR)	CM capacitor = 10 $\mu$ F				
	100 mV p-p at 1 kHz		60		dB
	100 mV p-p at 10 kHz		40		dB
<b>SINGLE-ENDED PGA INPUT</b>					
Full-Scale Input Voltage	PGAx_EN = 1, PGMx_BOOST = 0		0.49		V rms
	0 dBFS		1.38		V p-p
Dynamic Range <sup>1</sup>	20 Hz to 20 kHz, -60 dB input				
With A-Weighted Filter (RMS)			96		dB
With Flat 20 Hz to 20 kHz Filter			94		dB
THD + N Level	20 Hz to 20 kHz, -1 dBFS output				
			-88		dBFS
SNR <sup>2</sup>					
With A-Weighted Filter (RMS)			96		dB
With Flat 20 Hz to 20 kHz Filter			94		dB
PGA Gain Variation	Standard deviation				
With 0 dB Setting			0.05		dB
With 35.25 dB Setting			0.15		dB

Parameter	Test Conditions/Comments	Min	Typ	Max	Unit
PGA Boost	PGA_X_BOOST		10		dB
Interchannel Gain Mismatch			0.005		dB
Offset Error			0		mV
Gain Error			±0.2		dB
Interchannel Isolation			83		dB
PSRR	CM capacitor = 10 µF, 100 mV p-p at 1 kHz		70		dB
	100 mV p-p at 1 kHz		49		dB
MICROPHONE BIAS	MBIASx_EN = 1, 1 µF load				
Bias Voltage	MBIASx_LEVEL = 1		1.18		V
	MBIASx_LEVEL = 0		1.63		V
Bias Current Source				2	mA
Output Impedance			1		Ω
MICBIASx Isolation	MBIASx_LEVEL = 0		95		dB
	MBIASx_LEVEL = 1		99		dB
Noise <sup>3</sup>	AVDD = 1.8 V, 20 Hz to 20 kHz, A-weighted				
	MBIASx_LEVEL = 0		3.5		µV
	MBIASx_LEVEL = 1		3.5		µV
CONVERTERS DIGITAL					
Internal Converter Resolution	All digital-to-analog converters (DAC)/ADCs		24		Bits
Digital Gain					
Step			0.375		dB
Range		-71		+24	dB
Ramp Rate			4.5		dB/ms
DAC DIFFERENTIAL OUTPUT	Differential operation				
Full-Scale Output Voltage	0 dBFS to DAC		1.0		V <sub>rms</sub>
Dynamic Range <sup>1</sup>	Line output mode, 20 Hz to 20 kHz, -60 dB input				
With A-Weighted Filter (RMS)			105		dB
With Flat 20 Hz to 20 kHz Filter			102		dB
SNR <sup>2</sup>	Line output mode, 20 Hz to 20 kHz				
With A-Weighted Filter (RMS)			105		dB
With Flat 20 Hz to 20 kHz Filter			102		dB
THD + N Level	Line output mode, 20 Hz to 20 kHz, -1 dBFS		-93		dBV
Gain Error	Line output mode		±1.5		%
Dynamic Range <sup>1</sup>	Headphone mode, 20 Hz to 20 kHz, -60 dB input				
With A-Weighted Filter (RMS)			105		dB
With Flat 20 Hz to 20 kHz Filter			101		dB
SNR <sup>2</sup>	Headphone mode, 20 Hz to 20 kHz				
With A-Weighted Filter (RMS)			105		dB
With Flat 20 Hz to 20 kHz Filter			101		dB
THD + N Level	Headphone mode				
32 Ω Load	-1 dBFS, output power (P <sub>OUT</sub> ) = 27 mW		-75		dBV
	P <sub>OUT</sub> = 1 mW		-82		dBV
24 Ω Load	-2 dBFS, P <sub>OUT</sub> = 28 mW		-75		dBV
16 Ω Load	-3 dBFS, P <sub>OUT</sub> = 33 mW		-75		dBV
Headphone Output Power					
32 Ω Load	AVDD = 1.8 V, <0.1% THD + N		30		mW
24 Ω Load	AVDD = 1.8 V, <0.1% THD + N		40		mW
16 Ω Load	AVDD = 1.8 V, <0.1% THD + N		50		mW



Parameter	Test Conditions/Comments	Min	Typ	Max	Unit
Gain Error	Headphone mode		±2.5		%
DC Offset			±0.2		mV
PSRR	CM capacitor = 10 µF 100 mV p-p at 1 kHz		70		dB
	100 mV p-p at 10 kHz		70		dB
AVDD Undervoltage Trip Point			1.5		V
CM REFERENCE	CM pin				
Output			0.85		V
Source Impedance			5		kΩ
PHASED-LOCKED LOOP (PLL)					
Input Frequency	After input prescale	0.03		27	MHz
Output Frequency		32	49.152	50	MHz
Fractional Limits	Fractional mode, fraction part (N/M), see the PLL section	0.1		0.9	
Integer Limits	Fractional mode, integer part	2		1536	
Lock Time	48 kHz input		2.03		ms
	24.576 MHz input		0.46	0.55	ms
REGULATOR					
Line Regulation			1		mV/V
Load Regulation			0.5		mV/mA

<sup>1</sup> Dynamic range is the ratio of the sum of the noise and harmonic power in the band of interest with a –60 dBFS signal present to the full-scale power level in decibels.

<sup>2</sup> SNR is the ratio of the sum of all noise power in the band of interest with no signal present to the full-scale power level in decibels.

<sup>3</sup> These specifications are with 4.7 µF decoupling and 5.0 kΩ load on the pin.

## CRYSTAL AMPLIFIER SPECIFICATIONS

Supply voltages AVDD = IOVDD = 1.8 V and DVDD = 0.9 V, unless otherwise noted.

Table 2.

Parameter	Test Conditions/Comments	Min	Typ	Max	Unit
JITTER			270	500	ps
FREQUENCY RANGE		1		27	MHz
LOAD CAPACITANCE				20	pF

## DIGITAL INPUT AND OUTPUT SPECIFICATIONS

–40°C < T<sub>A</sub> < +85°C, IOVDD = 1.1 V to 1.98 V, unless otherwise noted.

Table 3.

Parameter	Symbols	Test Conditions/Comments	Min	Typ	Max	Unit
INPUT VOLTAGE						
High	V <sub>IH</sub>		0.7 × IOVDD			V
Low	V <sub>IL</sub>				0.3 × IOVDD	V
		IOVDD = 1.8 V, input high current (I <sub>IH</sub> ) at V <sub>IH</sub> = 1.1 V			10	µA
		Input low current (I <sub>IL</sub> ) at V <sub>IL</sub> = 0.45 V			10	µA
OUTPUT VOLTAGE HIGH	V <sub>OH</sub>					
Drive Strength						
Low		Output high current (I <sub>OH</sub> ) = 1 mA	0.71 × IOVDD	0.83 × IOVDD		V
High		I <sub>OH</sub> = 3 mA	0.71 × IOVDD	0.83 × IOVDD		V

Parameter	Symbols	Test Conditions/Comments	Min	Typ	Max	Unit			
OUTPUT VOLTAGE LOW Drive Strength	V <sub>OL</sub>	Output low current (I <sub>OL</sub> ) = 1 mA I <sub>OL</sub> = 3 mA							
Low							0.1 × IOVDD	0.3 × IOVDD	V
High							0.1 × IOVDD	0.3 × IOVDD	V
INPUT CAPACITANCE					5	pF			

**POWER SUPPLY SPECIFICATIONS**

Supply voltages AVDD = IOVDD = 1.8 V and DVDD = 0.9 V, unless otherwise noted. PLL disabled, direct master clock. Digital input/output (I/O) lines loaded with 25 pF.

Table 4.

Parameter	Test Conditions/Comments	Min	Typ	Max	Unit	
SUPPLIES						
AVDD Voltage		1.7	1.8	1.98	V	
DVDD Voltage		0.85	0.9	0.99	V	
IOVDD Voltage		1.1	1.8	1.98	V	
Digital I/O Current with IOVDD = 1.8 V	Crystal oscillator (24.576 MHz) enabled, IOVDD = 1.8 V Sampling frequency (f <sub>s</sub> ) = 48 kHz, BCLK_0 = 3.072 MHz f <sub>s</sub> = 192 kHz, BCLK_0 = 12.288 MHz f <sub>s</sub> = 48 kHz, BCLK_0 = 3.072 MHz f <sub>s</sub> = 192 kHz, BCLK_0 = 12.288 MHz					
Slave Mode, Serial Audio Port 0 (SPT0) On			0.271		mA	
				0.280		mA
Master Mode, SPT0 On				0.477		mA
			1.077		mA	

**POWER-DOWN CURRENT**

Supply voltages AVDD = IOVDD = 1.8 V and DVDD = 0.9 V externally supplied. PLL and crystal oscillator disabled.

Table 5.

Parameter	AVDD Current			DVDD Current			IOVDD Current			Unit
	Min	Typ	Max	Min	Typ	Max	Min	Typ	Max	
PD PIN LOW (HARDWARE POWER-DOWN)		0.52			11			0.69		μA
POWER_EN = 0										
No Keep Alives		0.52			11			0.69		μA
CM_KEEP_ALIVE = 1, KEEP_FDSP and KEEP_SDSP = 0		62			11			6.0		μA
CM_KEEP_ALIVE = 1, KEEP_FDSP and KEEP_SDSP = 1		64			11			6.0		μA

**TYPICAL POWER CONSUMPTION**

PLL enabled with master clock = 24.576 MHz (crystal oscillator enabled). DVDD = 0.9 V, and AVDD = IOVDD = 1.8 V supplied externally. Where applicable, ADC0 and ADC1 running at 384 kHz. FastDSP™ running at 384 kHz (biquad filters with 27-bit precision), and SigmaDSP® running at 48 kHz. SDSP\_SPEED = 0 for 24 MIPS measurements, and SDSP\_SPEED = 1 for 50 MIPS measurements. DAC0 running at 384 kHz, and DAC\_LPM = 1. One serial port input and output, configured as a slave, with headphone load of 32 Ω. Quiescent current (no signal).

Table 6.

ADC Channel	DAC Channel	ASRCI/ ASRCO Channel <sup>1</sup>	SigmaDSP MIPS	FastDSP Instruction	Digital Microphone Channels	Interpolator/ Decimator Channel	DVDD Current (mA)	AVDD Current (mA)	IOVDD Current (mA)
0	1	0	0	0	0	0	0.395	1.188	0.283
2	0	0	24	0	0	0	1.213	1.652	0.293
2	0	0	50	0	0	0	2.081	1.652	0.293
2	0	0	0	32	0	0	1.876	1.652	0.293
2	0	0	0	64	0	0	3.289	1.652	0.293
2	1	2/2	24	32	0	0	3.020	2.531	0.293
2	1	2/2	24	32	0	2/2	3.060	2.531	0.293
2	1	2/2	24	32	4	2/2	3.131	2.531	0.415
2	1	2/2	50	64	4	4/4	5.477	2.531	0.415

<sup>1</sup> ASRCI is the input asynchronous sample rate converter, and ASRCO is the output asynchronous sample rate converter.

Typical active noise cancelling (ANC) settings. Master clock = 24.576 MHz (crystal oscillator disabled and PLL bypassed). DVDD = 0.9 V, and AVDD = IOVDD = 1.8 V supplied externally. Two ADCs with PGA enabled. DAC configured for differential headphone operation, and DAC output loaded with 32 Ω and DAC\_LPM = 1. One serial port input and output, configured as slave. Two input and output asynchronous sample rate converters (ASRCs). Two slow to fast interpolators enabled. Both MICBIAS0 and MICBIAS1 enabled at  $0.9 \times AVDD$ . FastDSP running 32 instructions (biquad filters with 27-bit precision) at 384 kHz. SigmaDSP running 24 MIPS at 48 kHz. Quiescent current (no signal).

Table 7.

Operating Voltage	Power Management Setting	Typical Current (mA)			Total Power Consumption (mW)	Typical ADC THD + N (dB)	Typical High Power Output THD + N (dB)
		AVDD	DVDD	IOVDD			
AVDD = IOVDD = 1.8 V	Normal (default)	2.828	3.216	0.025	8.030	-89.5	-78 at 24 mW output
DVDD = 0.9 V	Power saving	2.453	3.215	0.025	7.354	-80.5	-78 at 24 mW output
	Extreme power saving	2.306	3.213	0.025	7.088	-78	-77.5 at 24 mW output

**DIGITAL FILTERS**

Table 8.

Parameter	Test Conditions/Comments	Min	Typ	Max	Unit
ADC INPUT TO DAC OUTPUT PATH					
Pass-Band Ripple	DC to 20 kHz, $f_s = 192$ kHz (ADC01_FCOMP = 1, DAC_FCOMP = 1)			$\pm 0.02$	dB
Group Delay <sup>1</sup>	$f_s = 192$ kHz		12.9		$\mu$ s
	$f_s = 384$ kHz		7.5		$\mu$ s
	$f_s = 768$ kHz		5		$\mu$ s
SAMPLE RATE CONVERTER					
Pass Band	LRCLK < 63 kHz			$0.475 \times f_s$	kHz
	63 kHz < LRCLK < 112 kHz			$0.4286 \times f_s$	
	LRCLK > 112 kHz		$0.4286 \times f_s$		
Audio Band Ripple	20 Hz to 20 kHz	-0.1		+0.1	dB
Input and Output Sample Frequency Range		7		224	kHz
Dynamic Range	$x\_LPM = 0$		130		dB
	$x\_LPM = 1$		130		dB
	$x\_LPM\_II = 1$		130		dB
THD + Noise	20 Hz to 20 kHz, input: typical at 1 kHz and maximum at 20 kHz				
	$x\_LPM = 0$		-130	-120	dBFS
	$x\_LPM = 1$		-120	-110	dBFS
	$x\_LPM\_II = 1$		-115	-90	dBFS
Startup Time to Lock				25	ms
PULSE DENSITY MODULATION (PDM) OUTPUTS					
Dynamic Range	20 Hz to 20 kHz, with A-weighted filter		126		dBFS
THD + N	20 Hz to 20 kHz, -6 dBFS input		-125		dBFS
Group Delay from ADC	$f_s = 384$ kHz		7.5		$\mu$ s
	$f_s = 768$ kHz		4.9		$\mu$ s

<sup>1</sup> Group delay is measured with fast digital signal processor (FDSP) using zero instructions.

**DIGITAL TIMING SPECIFICATIONS**

-40°C < T<sub>A</sub> < +85°C, IOVDD = 1.1 V to 1.8 V, and DVDD = 0.9 V to 0.99 V.

**Table 9.**

Parameter	Limit		Unit	Description
	Min	Max		
<b>MASTER CLOCK</b>				
t <sub>MPI</sub>	0.037	33.3	μs	MCLKIN period 30 kHz to 27 MHz input clock using PLL in integer mode
t <sub>MPF</sub>	0.037	1.0	μs	30 kHz to 27 MHz input clock using PLL in fractional mode
<b>SERIAL PORT</b>				
t <sub>BL</sub>	18		ns	BCLK_0 low pulse width (master and slave modes)
t <sub>BH</sub>	18		ns	BCLK_0 high pulse width (master and slave modes)
f <sub>BCLK</sub>	0.512	24.576	MHz	BCLK_0 frequency
t <sub>LS</sub>	3		ns	FSYNC_0 setup, time to BCLK_0 rising (slave mode)
t <sub>LH</sub>	5		ns	FSYNC_0 hold, time from BCLK_0 rising (slave mode)
f <sub>SYNC</sub>	8	768	kHz	FSYNC_0 frequency
t <sub>SS</sub>	3		ns	SDATA1_0 setup, time to BCLK_0 rising (master and slave modes)
t <sub>SH</sub>	10		ns	SDATA1_0 hold, time from BCLK_0 rising (master and slave modes)
t <sub>TS</sub>		6	ns	BCLK_0 falling to FSYNC_0 timing skew (master mode)
t <sub>SOD</sub>	0	16	ns	SDATA0_0 delay, time from BCLK_0 falling (master and slave modes), IOVDD at 1.62 V minimum
	0	32	ns	SDATA0_0 delay, time from BCLK_0 falling (master and slave modes), IOVDD at 1.1 V minimum
t <sub>SOTD</sub>	0	16	ns	BCLK_0 falling to SDATA0_0 driven in tristate mode
t <sub>SOTX</sub>	0	16	ns	BCLK_0 falling to SDATA0_0 tristated in tristate mode
<b>SERIAL PERIPHERAL INTERFACE (SPI) PORT</b>				
f <sub>SCLK</sub>		10	MHz	SCLK frequency
t <sub>CCPL</sub>	35		ns	SCLK pulse width low
t <sub>CCPH</sub>	35		ns	SCLK pulse width high
t <sub>CLS</sub>	5		ns	$\overline{SS}$ setup, time to SCLK rising
t <sub>CLH</sub>	40		ns	$\overline{SS}$ hold, time from SCLK rising
t <sub>CLPH</sub>	10		ns	$\overline{SS}$ pulse width high
t <sub>CDS</sub>	10		ns	MOSI setup, time to SCLK rising
t <sub>CDH</sub>	10		ns	MOSI hold, time from SCLK rising
t <sub>COD</sub>		30	ns	MISO delay, time from SCLK falling
t <sub>COTS</sub>		30	ns	MISO high-Z, time from $\overline{SS}$ rising
<b>I<sup>2</sup>C PORT</b>				
f <sub>SCL</sub>		1	MHz	SCL frequency
t <sub>SCLH</sub>	0.26		μs	SCL high
t <sub>SCLL</sub>	0.5		μs	SCL low
t <sub>SCS</sub>	0.26		μs	SCL rise setup time (to SDA falling), relevant for repeated start condition
t <sub>SCR</sub>		120	ns	SCL and SDA rise time, C <sub>LOAD</sub> = 400 pF
t <sub>SCH</sub>	0.26		μs	SCL fall hold time (from SDA falling), relevant for start condition
t <sub>DS</sub>	50		ns	SDA setup time (to SCL rising)
t <sub>SCF</sub>		120	ns	SCL and SDA fall time, C <sub>LOAD</sub> = 400 pF
t <sub>BFT</sub>	0.5		μs	SCL rise setup time (to SDA rising), relevant for stop condition

Parameter	Limit		Unit	Description
	Min	Max		
GENERAL-PURPOSE INPUT/ OUTPUT (GPIO) PINS				
$t_{GIL}$		$1.5 \times 1/f_s$	$\mu s$	MPx input latency, time until high or low value is read by core
$t_{RLPW}$	20		ns	PD low pulse width
DIGITAL MICROPHONE				
$t_{CF}^1$		12	ns	Digital microphone clock fall time
$t_{CR}^1$		14	ns	Digital microphone clock rise time
$t_{SETUP}$	10		ns	Digital microphone data setup time
$t_{HOLD}$	3		ns	Digital microphone data hold time
PDM OUTPUT				
$f_{PDM\_CLK}$		3.072	MHz	PDM clock frequency 3 MHz setting
		6.144	MHz	6 MHz setting
$t_{CF}^1$		12	ns	Digital PDM clock output fall time
$t_{CR}^1$		14	ns	Digital PDM clock output rise time
$t_{HOLD}$	35	46	ns	PDM data hold time

<sup>1</sup> Digital microphone clock rise and fall times are measured at 2 mA drive strength with 25 pF load.

**Digital Timing Diagrams**

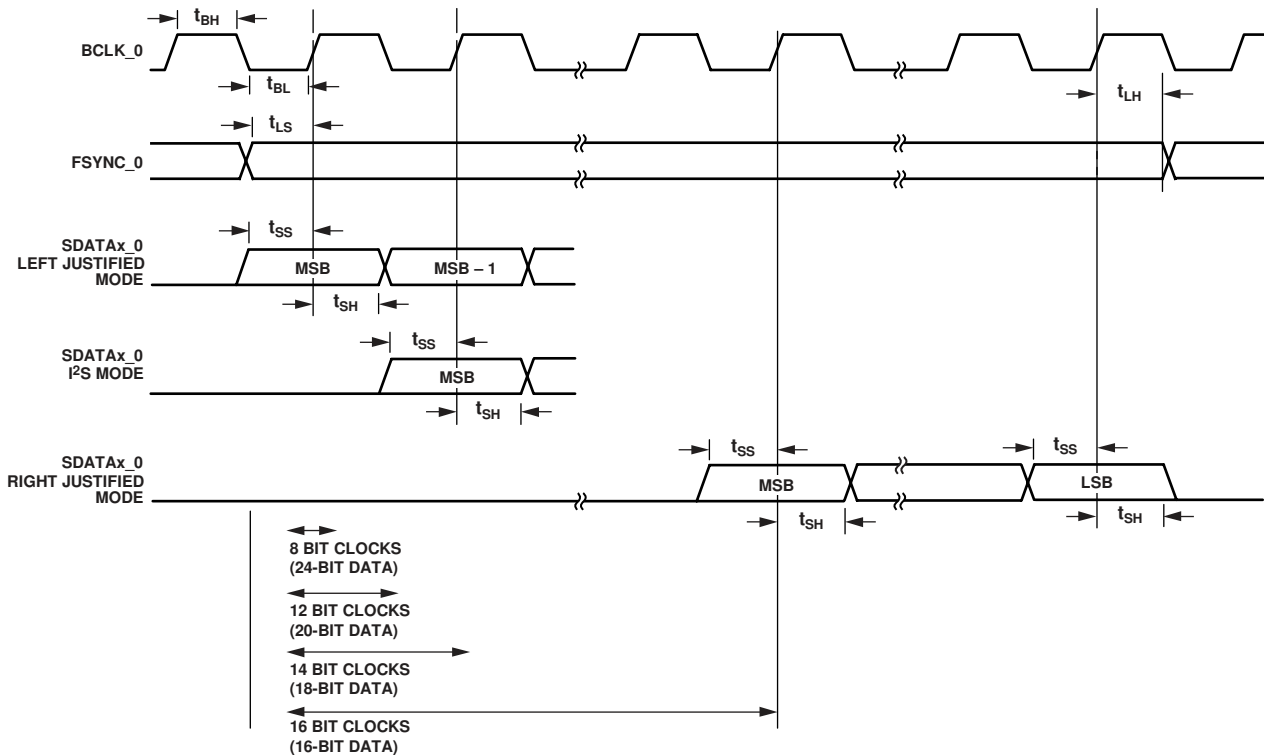

Figure 2. Serial Input Port Timing Diagram

20534-002

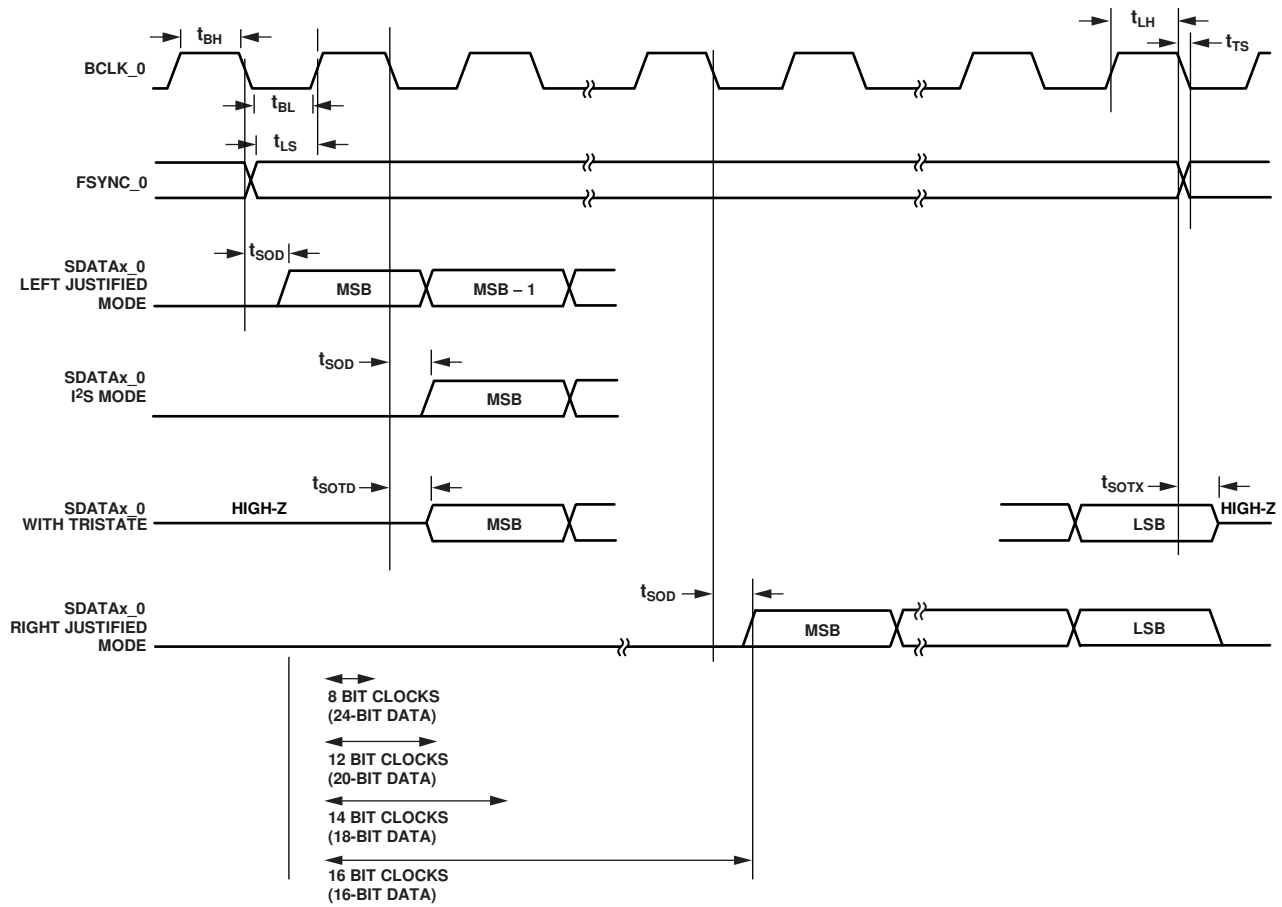

Figure 3. Serial Output Port Timing Diagram

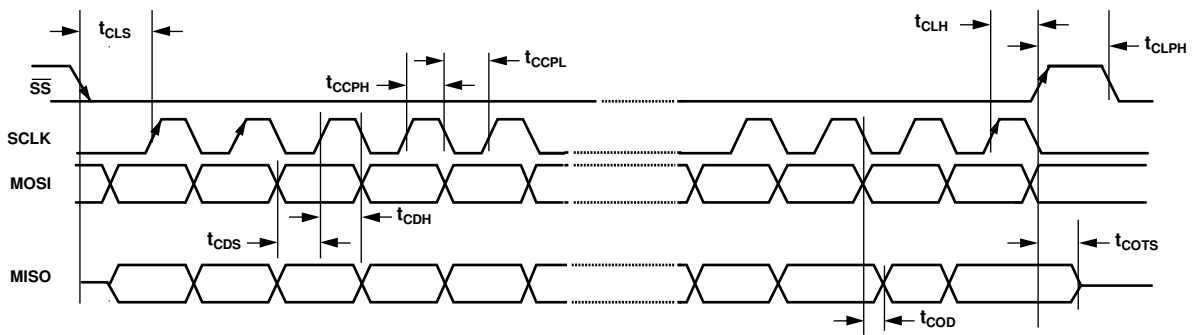

Figure 4. SPI Port Timing Diagram

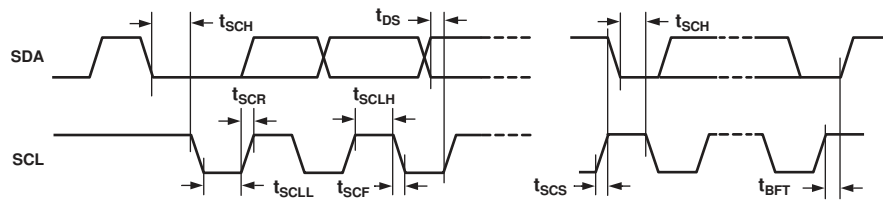

Figure 5. I²C Port Timing Diagram

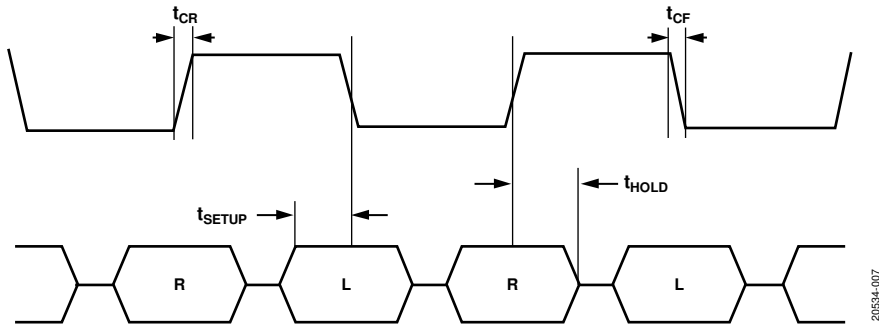

Figure 6. Digital Microphone Timing Diagram

20534-007

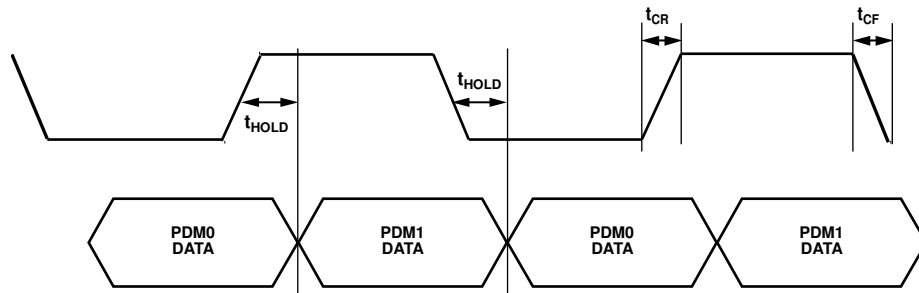

Figure 7. PDM Output Timing Diagram

20534-008



## ABSOLUTE MAXIMUM RATINGS

Table 10.

Parameter	Rating
Power Supply (AVDD, IOVDD)	−0.3 V to +1.98 V
Digital Supply (DVDD)	−0.3 V to +1.21 V
Input Current (Except Supply Pins)	±20 mA
Analog Input Voltage (Signal Pins)	−0.3 V to AVDD + 0.3 V
Digital Input Voltage (Signal Pins)	−0.3 to IOVDD + 0.3 V
Operating Temperature Range (Case)	−40°C to +85°C
Storage Temperature Range	−65°C to +150°C

Stresses at or above those listed under Absolute Maximum Ratings may cause permanent damage to the product. This is a stress rating only; functional operation of the product at these or any other conditions above those indicated in the operational section of this specification is not implied. Operation beyond the maximum operating conditions for extended periods may affect product reliability.

## THERMAL RESISTANCE

Thermal performance is directly linked to printed circuit board (PCB) design and operating environment. Careful attention to PCB thermal design is required.

$\theta_{JA}$  and  $\theta_{JC}$  are determined according to JEDEC51-9 on a 4-layer PCB with natural convection cooling.

Table 11. Thermal Resistance

Package Type	$\theta_{JA}$ <sup>1</sup>	$\theta_{JC}$ <sup>1</sup>	Unit
CB-42-2	46.7	0.3	°C/W

<sup>1</sup> Thermal impedance simulated values are based on a JEDEC 252P thermal test board with two thermal vias. See JEDEC JESD-51.

## ESD CAUTION



**ESD (electrostatic discharge) sensitive device.** Charged devices and circuit boards can discharge without detection. Although this product features patented or proprietary protection circuitry, damage may occur on devices subjected to high energy ESD. Therefore, proper ESD precautions should be taken to avoid performance degradation or loss of functionality.

# PIN CONFIGURATION AND FUNCTION DESCRIPTIONS

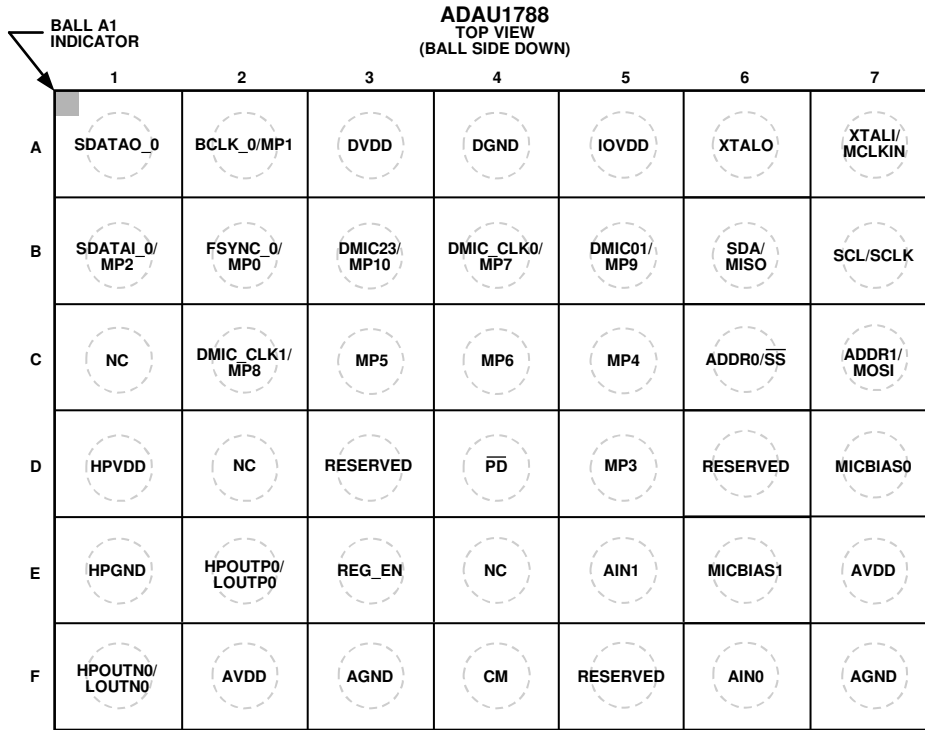

NC = NO CONNECTION. LEAVE THIS PIN OPEN.

Figure 8. Ball Configuration (Top View)

Table 12. Ball Function Descriptions

Ball No.	Mnemonic	Type <sup>1</sup>	Description
A1	SDATAO_0	D_IO	Serial Audio Port 0 Output Data.
A2	BCLK_0/MP1	D_IO	Serial Audio Port 0 Bit Clock (BCLK_0). Multipurpose Input/Output 1 (MP1).
A3	DVDD	PWR	Digital Core Supply. The digital supply can be generated from an on-board regulator or supplied directly from an external supply. In each case, decouple DVDD to DGND with a 1 µF and a 0.1 µF capacitor.
A4	DGND	PWR	Digital Ground. The AGND and DGND pins can be tied directly together in a common ground plane.
A5	IOVDD	PWR	Supply for the Digital Input and Output Pins. The digital output pins are supplied from IOVDD, and this pin sets the highest input voltage seen on the digital input pins. The current draw of this pin is variable because the current is dependent on the loads of the digital outputs. Decouple IOVDD to DGND with a 0.1 µF capacitor.
A6	XTALO	A_OUT	Crystal Clock Output. This pin is the output of the crystal amplifier. Do not use this pin to provide a clock to other ICs in the system.
A7	XTALI/MCLKIN	D_IN	Crystal Clock Input (XTALI). Master Clock Input (MCLKIN).

Ball No.	Mnemonic	Type <sup>1</sup>	Description
B1	SDATAI_0/MP2	D_IO	Serial Audio Port 0 Input Data (SDATAI_0). Multipurpose Input/Output 2 (MP2).
B2	FSYNC_0/MP0	D_IO	Serial Audio Port 0 Frame Sync/Left Right Clock (FSYNC_0). Multipurpose Input/Output 0 (MP0).
B3	DMIC23/MP10	D_IO	Digital Microphone Stereo Input 2 and Digital Microphone Stereo Input 3 (DMIC23). Multipurpose Input/Output 10 (MP10).
B4	DMIC_CLK0/MP7	D_IO	Digital Microphone Clock Output 0 (DMIC_CLK0). Multipurpose Input/Output 7 (MP7).
B5	DMIC01/MP9	D_IO	Digital Microphone Stereo Input 0 and Digital Microphone Stereo Input 1 (DMIC01). Multipurpose Input/Output 9 (MP9).
B6	SDA/MISO	D_IO	I <sup>2</sup> C Data (SDA). This pin is a bidirectional open-collector input. The line connected to this pin must have a 2.0 k $\Omega$ pull-up resistor. SPI Data Output (MISO). This SPI data output is used for reading back registers and memory locations. This pin is tristated when an SPI read is not active.
B7	SCL/SCLK	D_IN	I <sup>2</sup> C Clock (SCL). This pin is always an open-collector input when the device is in I <sup>2</sup> C control mode. When the device is in self-boot mode, this pin is an open-collector output (I <sup>2</sup> C master). The line connected to this pin must have a 2.0 k $\Omega$ pull-up resistor. SPI Clock (SCLK). This pin can either run continuously or be gated off between SPI transactions.
C1	NC	NC	No Connection. Leave this pin open.
C2	DMIC_CLK1/MP8	D_IO	Digital Microphone Clock Output 1 (DMIC_CLK1). Multipurpose Input/Output 8 (MP8).
C3	MP5	D_IO	Multipurpose Input/Output 5 (MP5). Connect this pin to DGND if not used.
C4	MP6	D_IO	Multipurpose Input/Output 6 (MP6). Connect this pin to DGND if not used.
C5	MP4	D_IO	Multipurpose Input/Output 4 (MP4). Connect this pin to DGND if not used.
C6	ADDR0/ $\overline{SS}$	D_IN	I <sup>2</sup> C Address 0 (ADDR0). SPI Latch Signal ( $\overline{SS}$ ). This pin must go low at the beginning of an SPI transaction and high at the end of a transaction. Each SPI transaction may take a different number of SCLK cycles to complete, depending on the address and read/write bit that are sent at the beginning of the SPI transaction.
C7	ADDR1/MOSI	D_IN	I <sup>2</sup> C Address 1 (ADDR1). SPI Data Input (MOSI).
D1	HPVDD	PWR	Headphone Amplifier Power, 1.8 V Analog Supply. Decouple this pin to HPGND with a 0.1 $\mu$ F capacitor. The PCB trace to this pin must be wider to supply the higher current necessary for driving the headphone outputs.
D2	NC	NC	No Connection. Leave this pin open.
D3	RESERVED	D_IN	Internal Use Only. Connect this pin to DGND.
D4	$\overline{PD}$	D_IN	Active Low Power-Down. All digital and analog circuits are powered down. There is an internal pull-down resistor on this pin. Therefore, the ADAU1788 is held in power-down mode if the input signal is floating while power is applied to the supply pins.
D5	MP3	D_IO	Multipurpose Input/Output 3. Connect this pin to DGND if not used.
D6	RESERVED	D_IN	Internal use only. Connect this pin to DGND.
D7	MICBIAS0	A_OUT	Bias Voltage for Electret Microphone 0. Decouple this pin with a 1 $\mu$ F capacitor.
E1	HPGND	PWR	Headphone Amplifier Ground.
E2	HPOUTP0/LOUTP0	A_OUT	Headphone Output Noninverted Channel 0 (HPOUTP0). Line Output Noninverted Channel 0 (LOUTP0).
E3	REG_EN	A_IN	Regulator Enable. Tie this pin to AVDD to enable the regulator and tie this pin to ground to disable the regulator.
E4	NC		No Connection. Leave this pin open.
E5	AIN1	A_IN	ADC1 Input.
E6	MICBIAS1	A_OUT	Bias Voltage for Electret Microphone 1. Decouple this pin with a 1 $\mu$ F capacitor.
E7	AVDD	PWR	1.8 V Analog Supply. Decouple this pin to AGND with a 0.1 $\mu$ F capacitor.

Ball No.	Mnemonic	Type <sup>1</sup>	Description
F1	HPOUTN0/LOUTN0	A_OUT	Headphone Output Noninverted Channel 0 (HPOUTP0). Line Output Noninverted Channel 0 (LOUTP0).
F2	AVDD	PWR	1.8 V Analog Supply. Decouple AVDD to AGND with a 0.1 $\mu$ F capacitor.
F3	AGND	PWR	Analog Ground. The AGND and DGND pins can be tied directly together in a common ground plane.
F4	CM	A_OUT	Common-Mode Reference, Fixed at 0.85 V Nominal. Connect a 10 $\mu$ F and a 0.1 $\mu$ F decoupling capacitor between this pin and AGND to reduce crosstalk between the ADCs and the DAC. The material of the capacitors is not critical. This pin can bias external analog circuits as long as the circuits are not drawing current from CM (for example, the noninverting input of an op amp).
F5	RESERVED	A_IN	Internal Use Only. Connect this pin to CM.
F6	AIN0	A_IN	ADC0 Input.
F7	AGND	PWR	Analog Ground.

<sup>1</sup> D\_IO means digital input/output, PWR means power, A\_OUT means analog output, D\_IN means digital input, NC means no connection, and A\_IN means analog input.

### TYPICAL PERFORMANCE CHARACTERISTICS

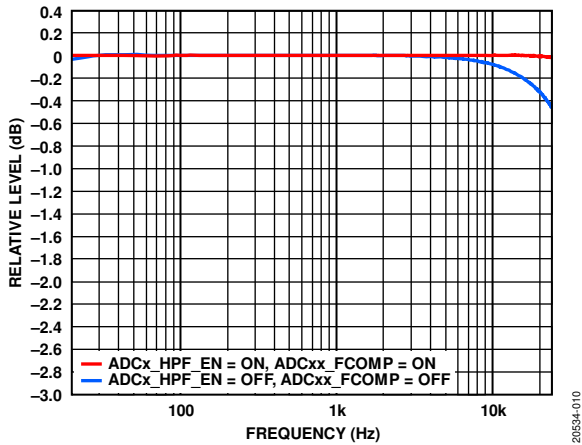

Figure 9. Frequency Response,  $f_s = 48$  kHz,  $-20$  dBV Input, Signal Path = AINx to SDATA0\_0, No PGA

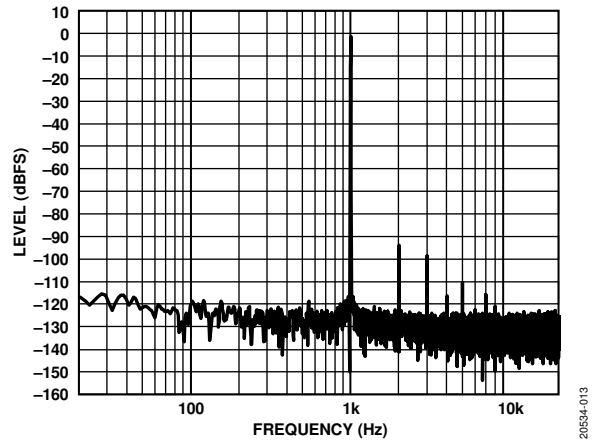

Figure 12. Fast Fourier Transform (FFT),  $-7$  dBV Input,  $-1$  dBFS Output,  $f_s = 48$  kHz, Signal Path = AINx to SDATA0\_0, No PGA

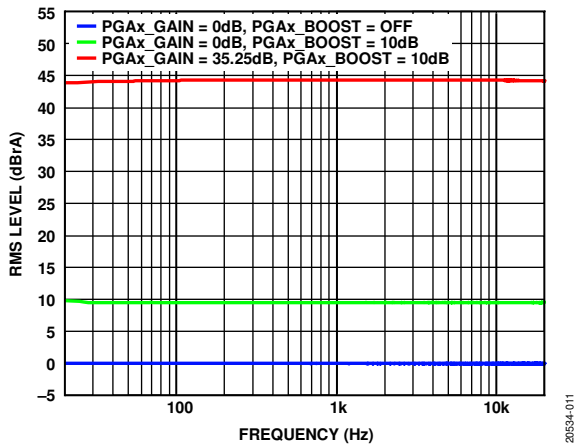

Figure 10. Frequency Response,  $f_s = 48$  kHz, Signal Path = AINx to SDATA0\_0, Output Relative to PGA Gain Settings (0 dB/10 dB/35.25 dB + 10 dB Boost)

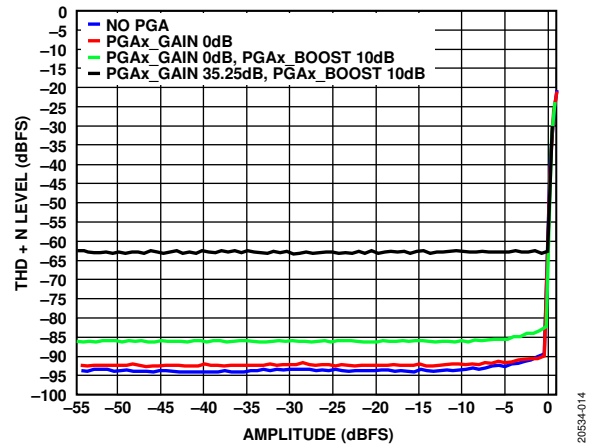

Figure 13. THD + N Level vs. Amplitude,  $f_s = 48$  kHz, Signal Path = AINx to SDATA0\_0

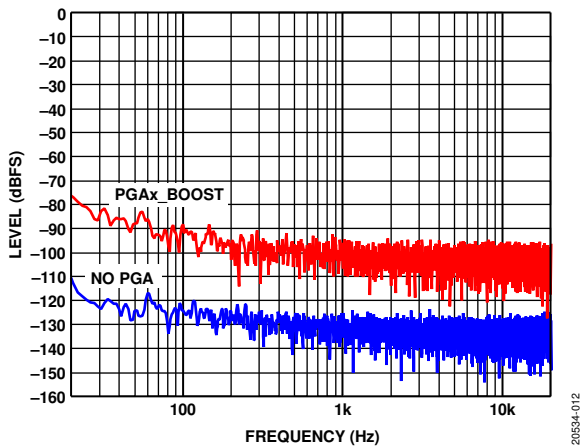

Figure 11. FFT, No Signal,  $f_s = 48$  kHz, Signal Path = AINx to SDATA0\_0, No PGA and 35.25 dB PGAx\_GAIN + 10 dB PGAx\_BOOST

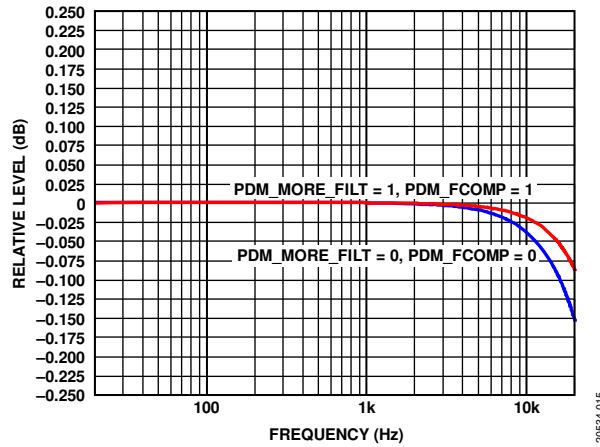

Figure 14. Frequency Response,  $f_s = 48$  kHz, Signal Path = SDATA1\_0 to PDM Output

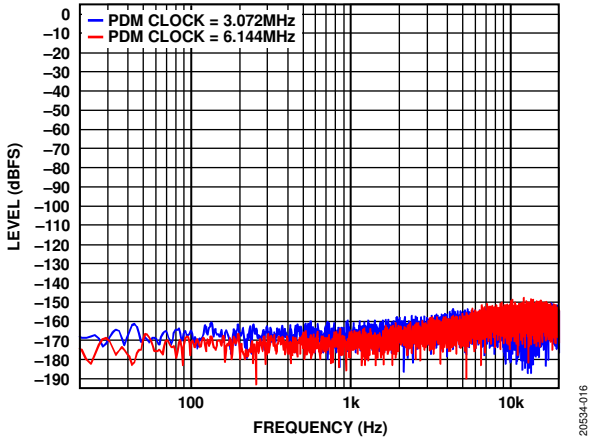

Figure 15. FFT, No Signal,  $f_s = 48$  kHz Throughout, Signal Path = SDATA1\_0 to FastDSP to PDM Output

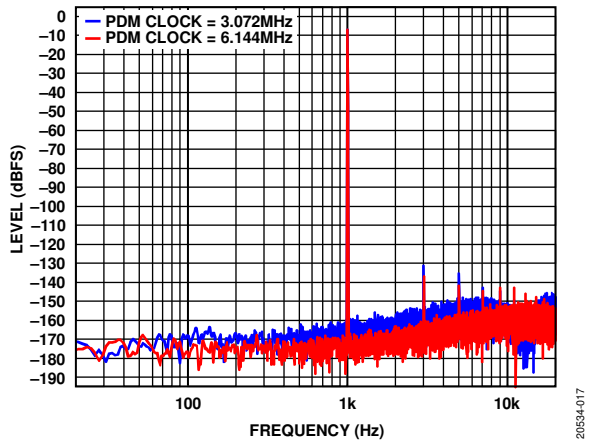

Figure 16. FFT,  $-7$  dBFS,  $f_s = 48$  kHz Throughout, Signal Path = SDATA1\_0 to FastDSP to PDM Output

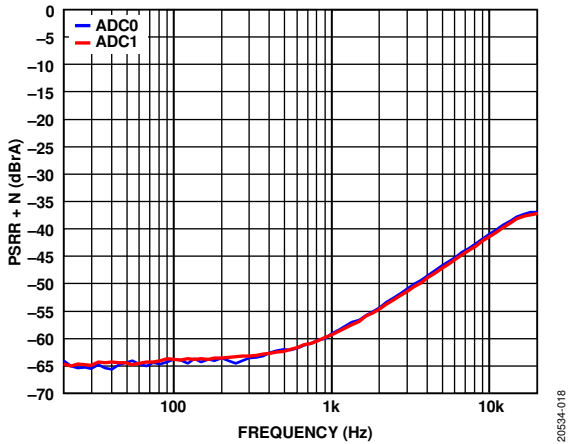

Figure 17. PSRR + N, Signal Path = AINx to SDATA0\_0,  $f_s = 48$  kHz,  $100$  mV p-p Ripple Input on AVDD, No PGA (0 dBra =  $-23.3$  dBFS)

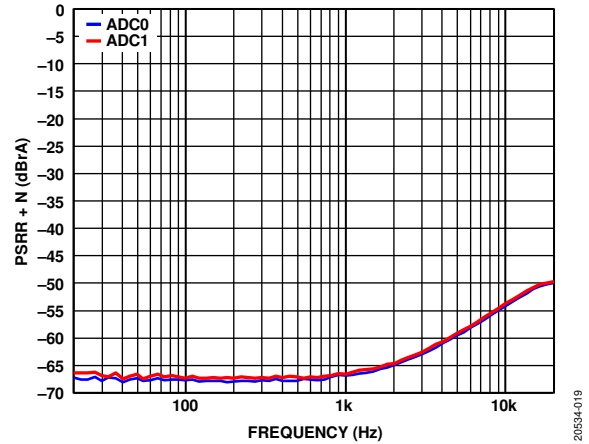

Figure 18. PSRR + N, Signal Path = AINx to SDATA0\_0,  $f_s = 48$  kHz,  $100$  mV p-p Ripple Input on AVDD, PGA = 0 dB (0 dBra =  $-23.3$  dBFS)

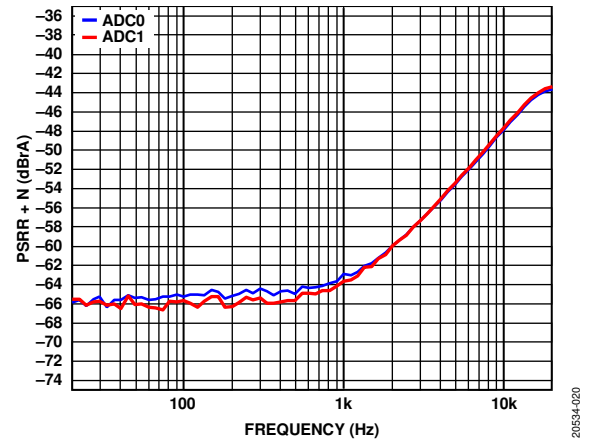

Figure 19. PSRR + N, Signal Path = AINx to SDATA0\_0,  $f_s = 48$  kHz,  $100$  mV p-p Ripple Input on AVDD, PGA = 10 dB (0 dBra =  $-23.3$  dBFS)

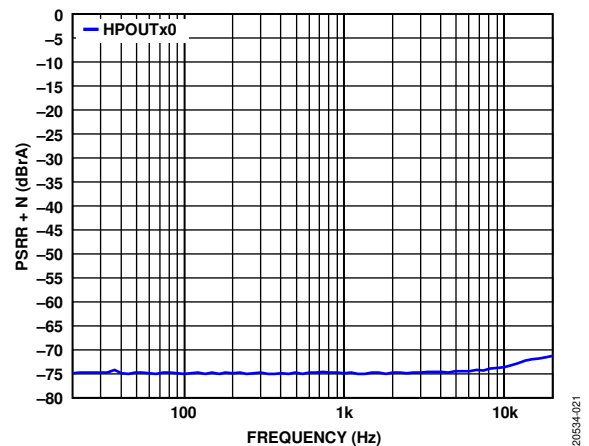

Figure 20. PSRR + N, Signal Path = SDATA1\_0 to HPOUTx0,  $f_s = 48$  kHz,  $100$  mV p-p Ripple Input on AVDD (0 dBra =  $-29$  dBV)

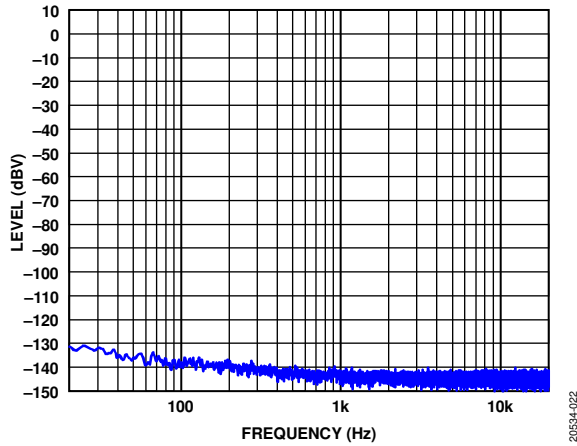

Figure 21. FFT, No Signal,  $f_s = 48$  kHz, Signal Path = SDATA1\_0 to HPOUTx0, Headphone Mode, Load =  $16 \Omega$

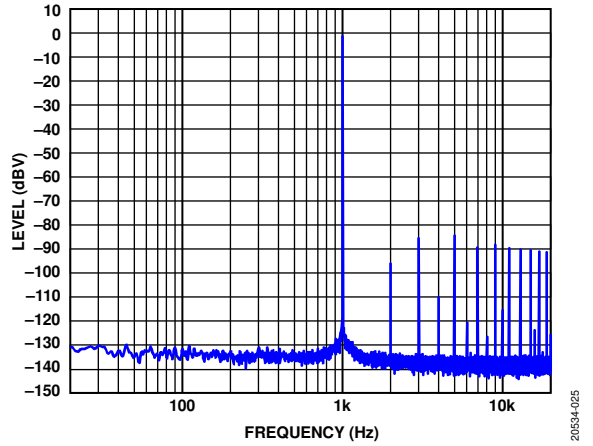

Figure 24. FFT,  $-1$  dBFS,  $f_s = 48$  kHz, Signal Path = SDATA1\_0 to HPOUTx0, Headphone Mode, Load =  $24 \Omega$

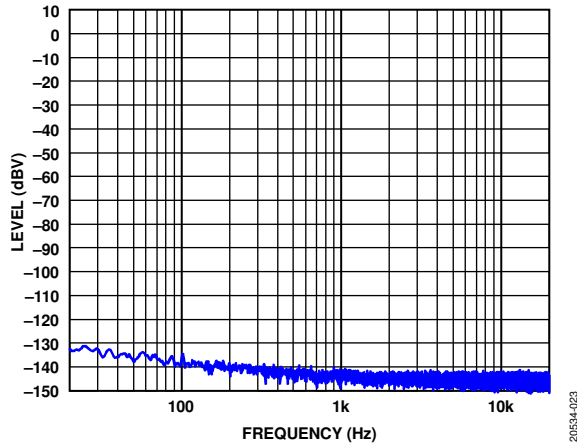

Figure 22. FFT, No Signal,  $f_s = 48$  kHz, Signal Path = SDATA1\_0 to LOUTx0, Line Output Mode, Load =  $10 \text{ k}\Omega$

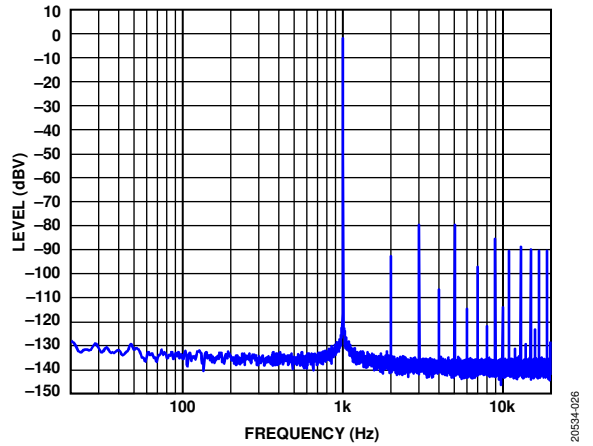

Figure 25. FFT,  $-1$  dBFS,  $f_s = 48$  kHz, Signal Path = SDATA1\_0 to HPOUTx0, Headphone Mode, Load =  $16 \Omega$

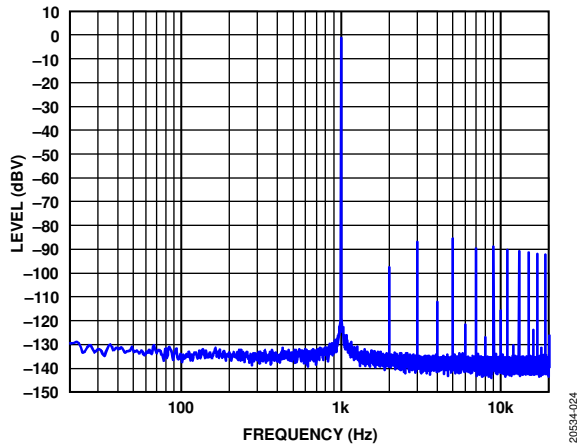

Figure 23. FFT,  $-1$  dBFS,  $f_s = 48$  kHz, Signal Path = SDATA1\_0 to HPOUTx0, Headphone Mode, Load =  $32 \Omega$

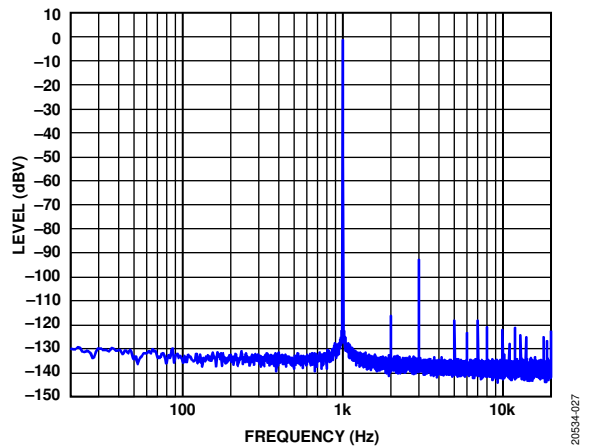

Figure 26. FFT,  $-1$  dBFS,  $f_s = 48$  kHz, Signal Path = SDATA1\_0 to LOUTx0, Line Output Mode, Load =  $10 \text{ k}\Omega$

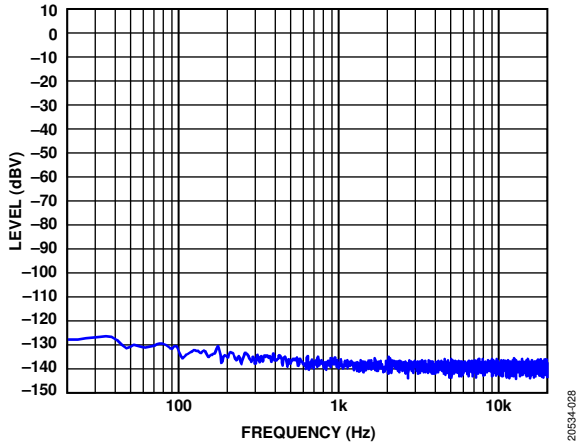

Figure 27. FFT, No Signal,  $f_s = 768$  kHz, Signal Path = SDATA1\_0 to Interpolator to FastDSP to HPOUTx0, Headphone Mode, Load = 16  $\Omega$

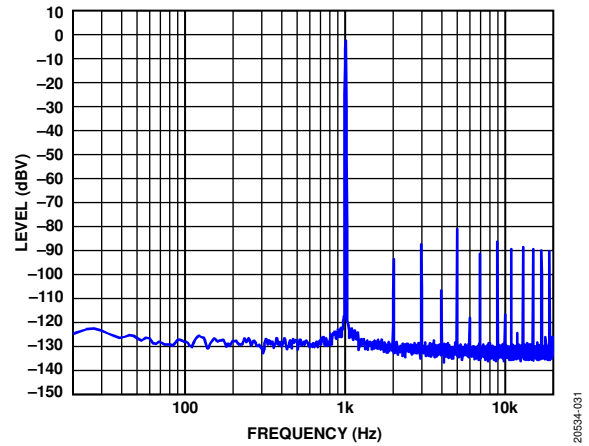

Figure 30. FFT, -1 dBFS,  $f_s = 768$  kHz, Signal Path = SDATA1\_0 to Interpolator to FastDSP to LOUTx0, Line Output Mode, Load = 10 k $\Omega$

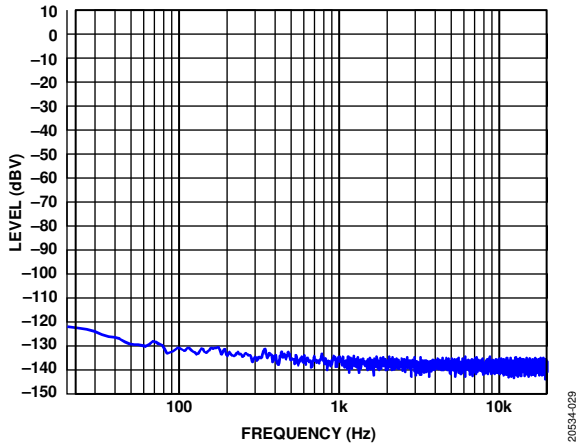

Figure 28. FFT, No Signal,  $f_s = 768$  kHz, Signal Path = SDATA1\_0 to Interpolator to FastDSP to LOUTx0, Line Output Mode, Load = 10 k $\Omega$

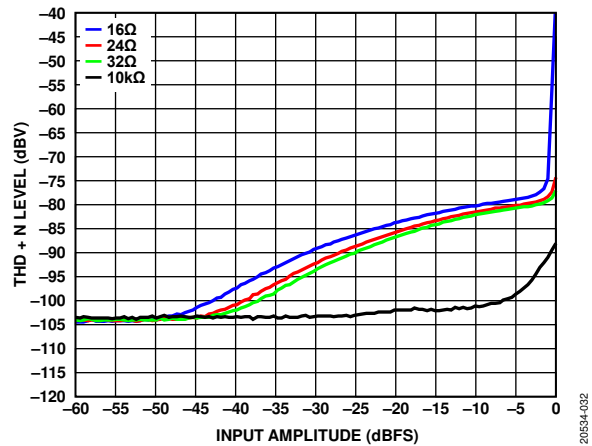

Figure 31. THD + N Level vs. Input Amplitude,  $f_s = 48$  kHz, 16  $\Omega$ , 24  $\Omega$ , 32  $\Omega$ , or 10 k $\Omega$ , Signal Path = SDATA1\_0 to HPOUTx0/LOUTx0

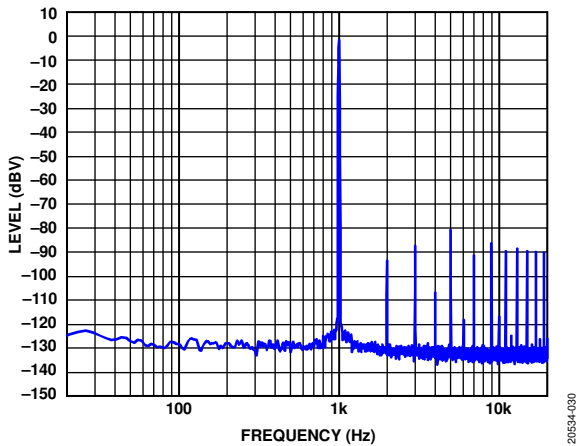

Figure 29. FFT, -1 dBFS,  $f_s = 768$  kHz, Signal Path = SDATA1\_0 to Interpolator to FastDSP to HPOUTx0, Headphone Mode, Load = 16  $\Omega$

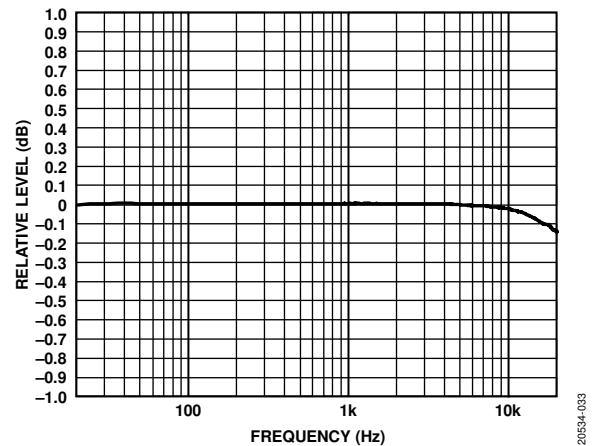

Figure 32. Relative Level vs. Frequency,  $f_s = 48$  kHz, Signal Path = SDATA1\_0 to HPOUTx0/LOUTx0, 16  $\Omega$  or 10 k $\Omega$



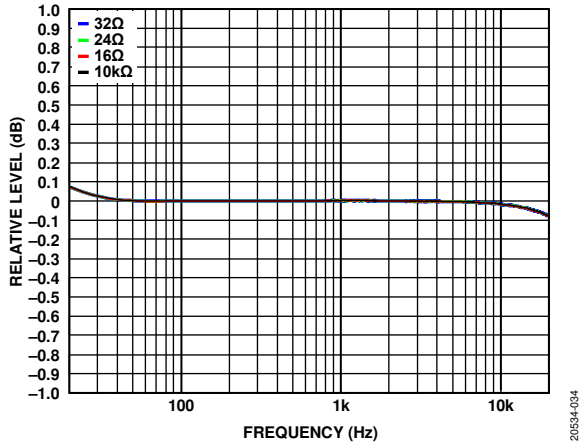

Figure 33. Relative Level vs. Frequency,  $f_s = 768$  kHz, Signal Path = SDATAI\_0 to Interpolator to FastDSP to HPOUTx0/LOUTx0, 16  $\Omega$  to 10k  $\Omega$

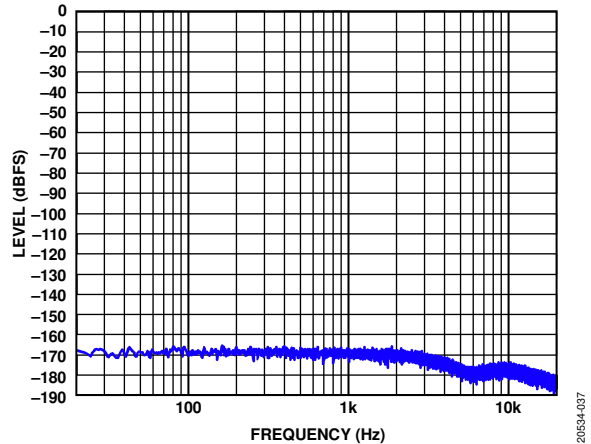

Figure 36. FFT, No Signal,  $f_s = 48$  kHz Throughout Except FastDSP = 768 kHz, Signal Path = SDATAI\_0 to SigmaDSP to Interpolator to FastDSP to Decimator to SDATAO\_0

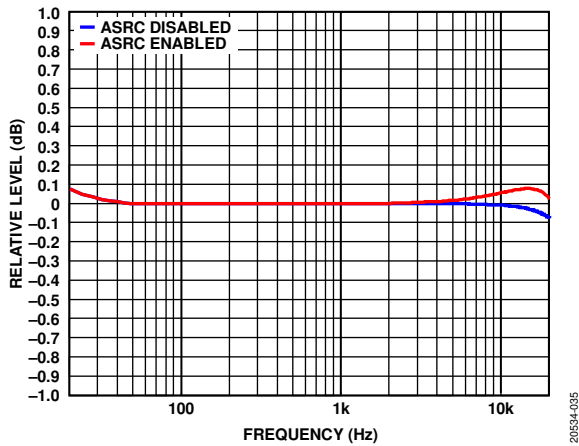

Figure 34. Relative Level vs. Frequency,  $f_s = 48$  kHz Throughout Except FastDSP = 768 kHz, Signal Path = SDATAI\_0 to ASRCI to SigmaDSP to Interpolator to FastDSP to Decimator to ASRCO to SDATAO\_0

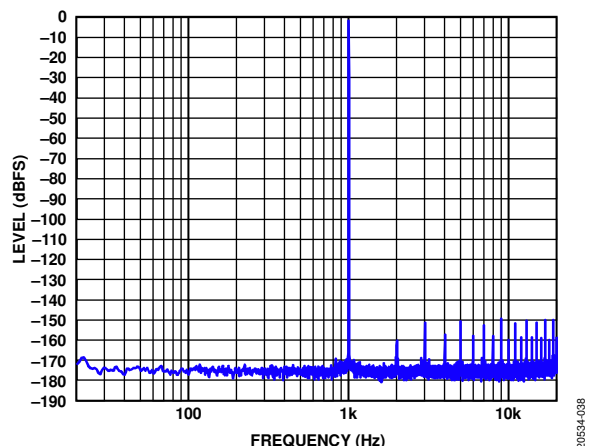

Figure 37. FFT, -1 dBFS,  $f_s = 48$  kHz Throughout Except FastDSP = 768 kHz, Signal Path = SDATAI\_0 to ASRCI to SigmaDSP to Interpolator to FastDSP to Decimator to ASRCO to SDATAO\_0

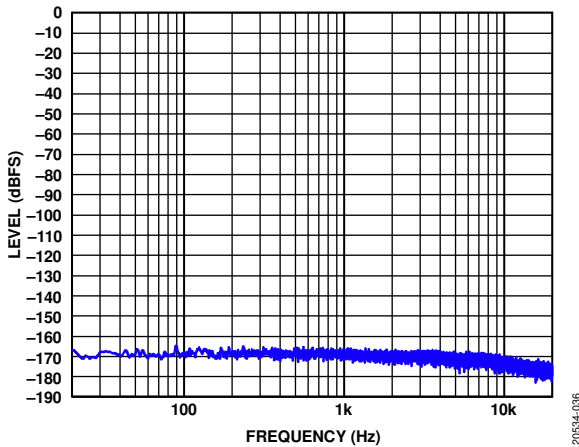

Figure 35. FFT, No Signal,  $f_s = 48$  kHz Throughout Except FastDSP = 768 kHz, Signal Path = SDATAI\_0 to ASRCI to SigmaDSP to Interpolator to FastDSP to Decimator to ASRCO to SDATAO\_0

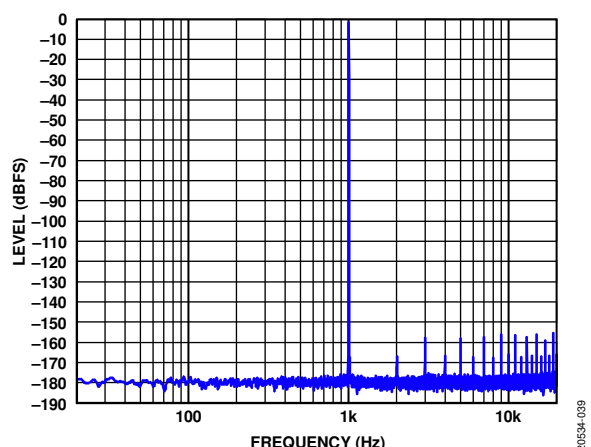

Figure 38. FFT, -1 dBFS,  $f_s = 48$  kHz Throughout Except FastDSP = 768 kHz, Signal Path = SDATAI\_0 to SigmaDSP to Interpolator to FastDSP to Decimator to SDATAO\_0

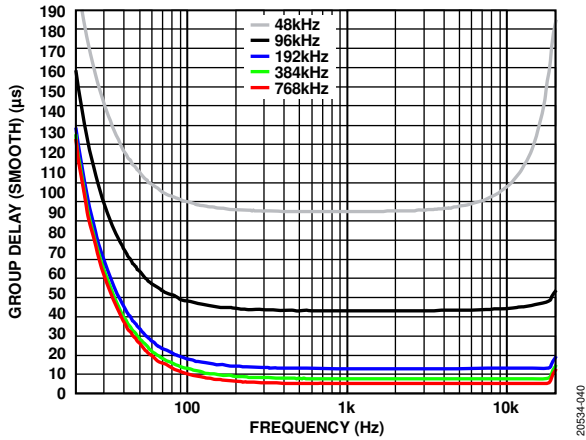

Figure 39. Group Delay (Smooth) vs. Frequency,  $f_s = 192$  kHz to 768 kHz, Signal Path = AINx to FastDSP to HPOUTx0/LOUTx0

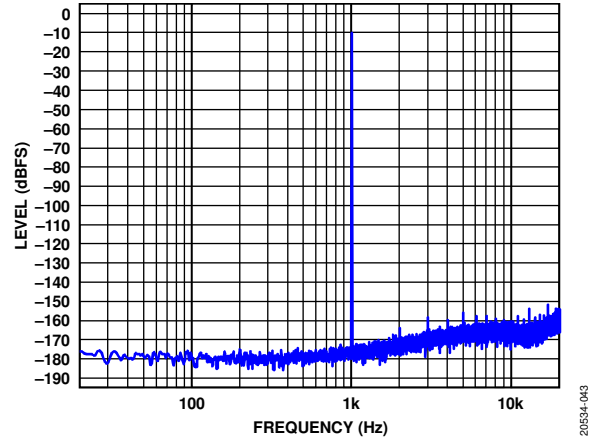

Figure 42. FFT, -10 dBFS, DMIC\_CLKx\_RATE = 3.072 MHz, Signal Path = DMICxx to SDATAO\_0

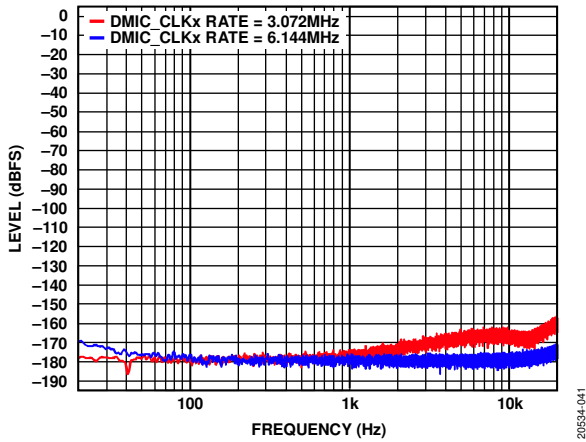

Figure 40. FFT, No Signal, DMIC\_CLKx\_RATE = 3.072 MHz to 6.144 MHz, Signal Path = DMICxx to SDATAO\_0

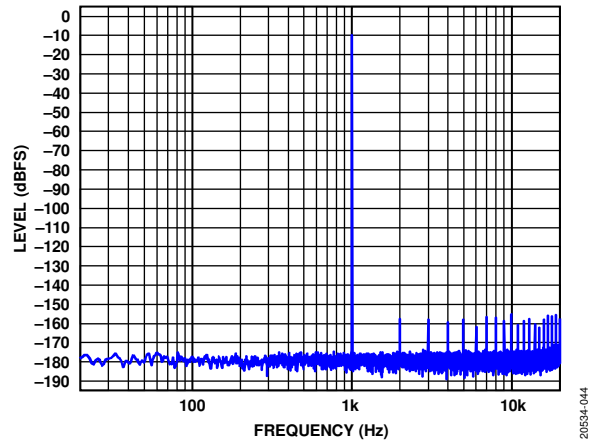

Figure 43. FFT, -10 dBFS, DMIC\_CLKx\_RATE = 3.072 MHz, Signal Path = DMICxx to SDATAO\_0

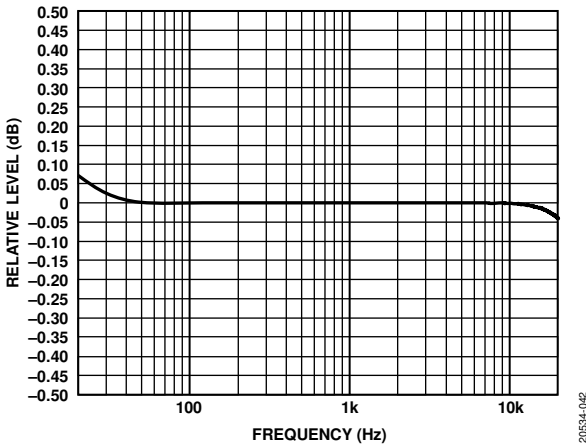

Figure 41. Relative Level vs. Frequency, DMIC\_CLKx\_RATE = 3.072 MHz to 6.144 MHz, Signal Path = DMICxx to SDATAO\_0

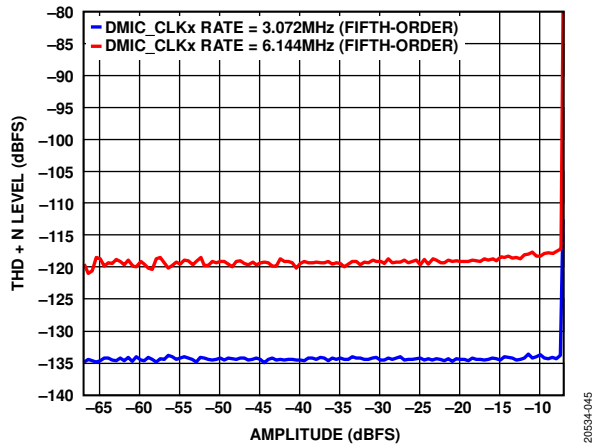

Figure 44. THD + N Level vs. Amplitude, -10 dBFS, DMIC\_CLKx\_RATE = 3.072 MHz to 6.144 MHz, Signal Path = DMICxx to SDATAO\_0

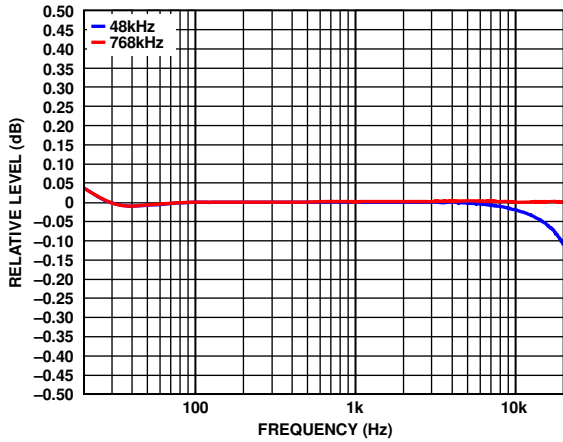

Figure 45. Relative Level vs. Frequency, Headphone/Line Output Mode, Load = 16 Ω to 10 kΩ,  $f_s = 48$  kHz and 768 kHz, Signal Path = AIN0 to DAC0

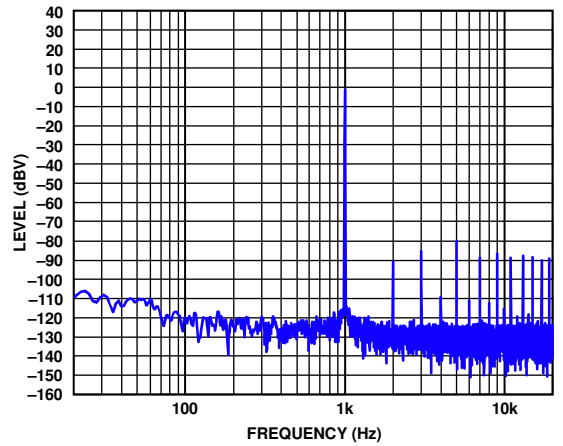

Figure 48. FFT, -1 dBV, Headphone Mode, Load = 16 Ω,  $f_s = 48$  kHz to 768 kHz, Signal Path = AINx to HPOUTx0

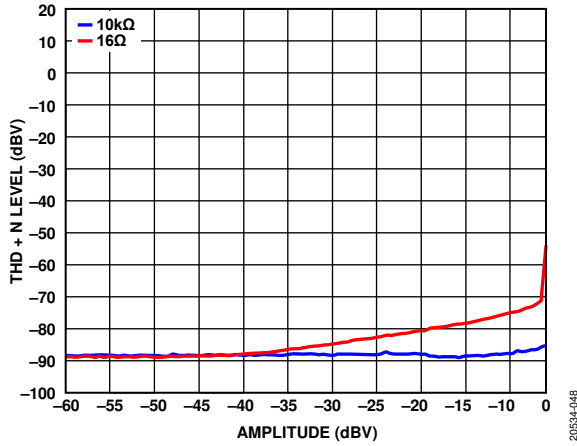

Figure 46. THD + N Level vs. Amplitude,  $f_s = 48$  kHz to 768 kHz, Load = 10 kΩ and 16 Ω, Signal Path = AINx to HPOUTx0/LOUTx0

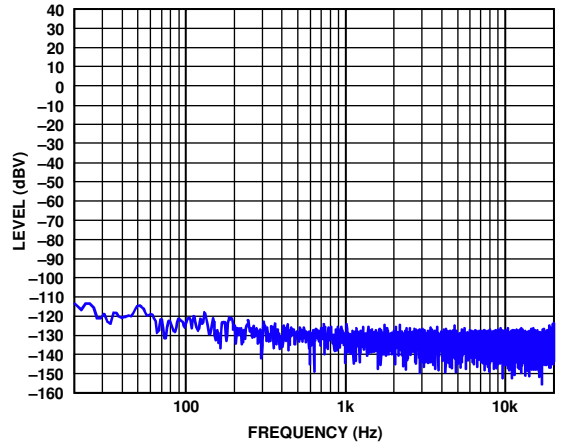

Figure 49. FFT, No Signal, Load = 16 Ω to 10 kΩ,  $f_s = 48$  kHz to 768 kHz, Signal Path = AINx to HPOUTx0/LOUTx0

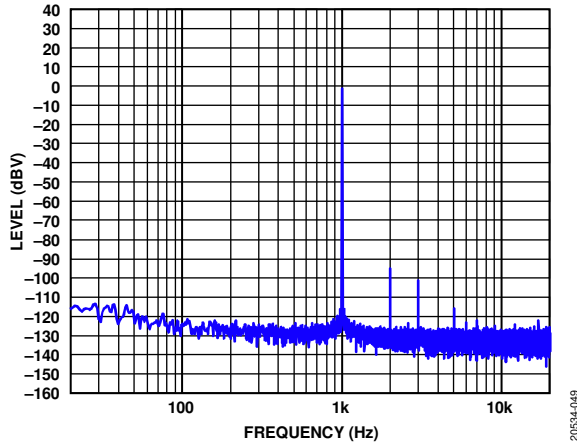

Figure 47. FFT, -1 dBV, Line Output Mode, Load = 10 kΩ,  $f_s = 48$  kHz to 768 kHz, Signal Path = AIN0 to LOUTx0

SYSTEM BLOCK DIAGRAM

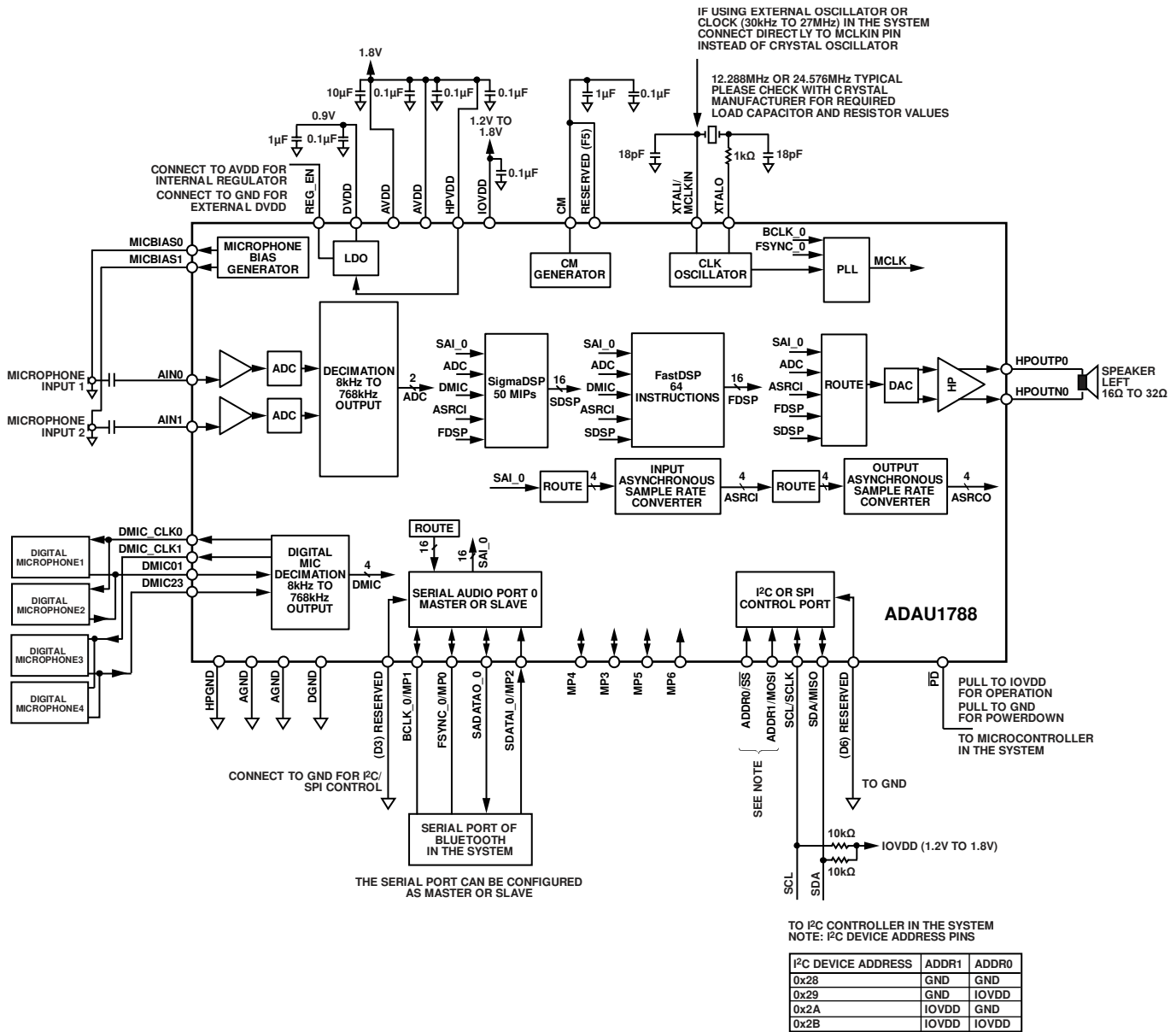

Figure 50. ADAU1788 System Block Diagram with Analog Microphones, Self Boot Mode

20534-457

## THEORY OF OPERATION

The ADAU1788 is a low power audio codec with optimized audio processing cores, making the device ideal for noise cancelling applications that require high quality audio, low power, small size, and low latency. The two ADC and one DAC channels each have an SNR of at least 96 dB and a THD + N level of at least -88 dB. The serial audio port is compatible with I<sup>2</sup>S, left justified, right justified, and TDM modes, with tristating for interfacing to digital audio data. The operating voltage is 1.8 V, with an on-board regulator generating the digital supply voltage. If desired, the regulator can be powered down, and the voltage can be supplied externally.

The input signal path includes flexible configurations that can accept single-ended analog microphone inputs as well as up to eight digital microphone inputs. Two microphone bias pins provide seamless interfacing to electret microphones. Each input signal has its own PGA for volume adjustment.

The ADCs and DAC are high quality, 24-bit  $\Sigma$ - $\Delta$  converters that operate at a selectable 12 kHz to 768 kHz sampling rate. The ADCs and DAC have an optional high-pass filter with a cutoff frequency of 1 Hz and fine-step digital soft volume controls.

The mono DAC output is capable of differentially driving a headphone earpiece speaker with 16  $\Omega$  impedance or higher. There is also the option to change to line output mode when the output is lightly loaded.

The SigmaDSP core is optimized for low power audio processing. This core can be graphically programmed using the [SigmaStudio](#)<sup>®</sup> software from Analog Devices, Inc. This software includes a library of audio processing blocks such as filters, dynamics

processors, mixers, and low level DSP functions for fast, graphical development of custom signal flows.

The FastDSP core has a reduced instruction set that optimizes this codec for noise cancellation. The program random access memory (RAM) and parameter RAM can be loaded with a custom audio processing signal flow built using [SigmaStudio](#). The values stored in the parameter RAM control individual signal processing blocks.

Use the [SigmaStudio](#) software to program and control the cores through the control port. Along with designing and tuning a signal flow, the tools can configure all of the ADAU1788 registers. The [SigmaStudio](#) graphical user interface (GUI) allows anyone with digital or analog audio processing knowledge to design the DSP signal flow and export the flow to a target application. The interface also provides enough flexibility and programmability for an experienced DSP programmer to have control of the design. In [SigmaStudio](#), the user can connect graphical blocks (such as biquad filters, volume controls, and arithmetic operations), compile the design, and load the program and parameter files into the ADAU1788 memory through the control port.

The ADAU1788 can generate the internal clocks from a wide range of input clocks by using the on-board bypassable fractional PLL. The PLL accepts inputs from 30 kHz to 27 MHz. For standalone operation, the clock can be generated using the on-board crystal oscillator.

The ADAU1788 is provided in a small, 42-ball, 2.695 mm  $\times$  2.320 mm WLCSP.

## SYSTEM CLOCKING AND POWER-UP

### POWER-DOWN OPERATION AND OPTIONS

When pulled low, the  $\overline{\text{PD}}$  pin puts the chip in the lowest power state, hardware full chip power-down. If the regulator is used, it also powers down during this state. The chip fully resets in this state and retains no state memory. No communication with the device is possible when the  $\overline{\text{PD}}$  pin is low.

By default, out of reset, the chip is in the lowest power state that can be entered via a control interface, software full chip power-down. To enter or exit this power state, use the `POWER_EN` bit, Bit 0 of Register 0xC00D. When `POWER_EN = 0`, the I<sup>2</sup>C/SPI control ports are operational, and everything else is powered down except for the regulator and the crystal, if used. To achieve the lowest power state, set the `XTAL_EN` bit (Bit 1 of Register 0xC005) = 0. The digital portion of the chip has several power domains. By default, only the domain that powers the control ports and their associated registers are powered on, and the rest of the digital design has its power supplies gated, and its state is lost.

There are two options to retain additional state memory during a software full chip power-down. The `KEEP_SDSP` and `KEEP_FDSP` bits, Bit 1 and Bit 0 of Register 0xC00C, respectively, can retain the state of the SigmaDSP program and parameter memories and/or the FastDSP program and parameter memories. The control register map always retains its state when `POWER_EN = 0`.

When `POWER_EN = 0`, the CM pin or the common-mode output can either maintain its state or not by using the `CM_KEEP_ALIVE` bit, Bit 4 of Register 0xC00C. When `CM_KEEP_ALIVE = 0`, the CM voltage is lost when `POWER_EN = 0`, thus producing the lowest possible software power-down current. However, with `CM_KEEP_ALIVE = 0`, the ADAU1788 has a longer turn on time because the PLL and other analog blocks rely on the CM voltage. A wait time of 35 ms is needed for CM to charge before any analog blocks, such as the PLL, can be enabled.

Conversely, with `CM_KEEP_ALIVE = 1`, the power-down current is higher, but the start-up time is faster because the 35 ms wait time can be omitted.

If `CM_KEEP_ALIVE = 1`, use the `CM_STARTUP_OVER` bit, Bit 2 of Register 0xC00D, to fast charge the CM voltage and to have the lowest turn on time by setting `CM_STARTUP_OVER = 0` before `POWER_EN` is set to 1. Then, after the 35 ms wait time, set `CM_STARTUP_OVER = 1` to keep power consumption low. The reset state of `CM_STARTUP_OVER` is 0. Therefore, if the PD pin is used to power down the device, the step of setting `CM_STARTUP_OVER` to 0 can be omitted.

When `POWER_EN = 1`, the power supplies on the rest of the digital portion of the chip are enabled. Therefore, this register must be set first during the power-up sequence.

The PLL and crystal must be configured and enabled after `CM_STARTUP_OVER` sequencing is complete. After all the internal digital power supplies are powered up, the PLL is locked, and other needed sequencing is complete, the `POWER_UP_COMPLETE` bit (Bit 7, Register 0xC0AB) or an interrupt request (IRQ) indicates such. The `IRQ1_POWER_UP_COMPLETE` is Bit 4 of Register 0xC0B1. The `IRQ2_POWER_UP_COMPLETE` is Bit 4 of Register 0xC0B4. If the IRQs are used to request an interrupt after `POWER_UP_COMPLETE`, the IRQs must be unmasked. The `IRQ1_POWER_UP_COMPLETE_MASK` bit (Bit 4, Register 0xC0A4) must be cleared. Similarly, the `IRQ2_POWER_UP_COMPLETE` (Bit 4, Register 0xC0A7) must be cleared. By default, the IRQs for `POWER_UP_COMPLETE` are masked.

After `POWER_UP_COMPLETE = 1`, the DSP memories can be programmed.

The ADAU1788 has highly flexible block level power controls. Each individual channel of each block can be powered on or off separately. There is a control bit, `MASTER_BLOCK_EN`, that by default is 0 and that overrides all block level enables except for `PLL_EN`, `XTAL_EN`, `SDSP_EN`, and `FDSP_EN`. The PLL, SigmaDSP, and FastDSP can be enabled, even when `MASTER_BLOCK_EN = 0`. All other blocks are always in power-down in this state, allowing the PLL to be enabled and locked and the DSP memories to be initialized before all other signal path blocks are enabled.

When configuring the devices, it is recommended to fully set up all control registers and block level power controls to their desired state, to allow the PLL to lock, to initialize the DSP memories to be used, and then to enable the blocks by setting `MASTER_BLOCK_EN = 1`.

Block level power controls and other settings can be changed on-the-fly while the chip is active. However, care must be taken when enabling or disabling blocks other than the DAC and/or headphone mode blocks that are actively routed out to the DAC and/or headphone mode as audible artifacts may occur.

To power down the chip, set MASTER\_BLOCK\_EN and POWER\_EN low. The device then powers down all blocks and performs any required power-down sequencing.

An overview of the power-up sequencing follows:

1. Set  $\overline{PD} = 1$  if using  $\overline{PD}$  to turn on the low dropout (LDO) regulator, if in use.
2. Wait 20 ms if REG\_EN = 1.
3. If CM\_KEEP\_ALIVE = 0 and REG\_EN = 0, ensure that CM\_STARTUP\_OVER = 0.
4. Set POWER\_EN = 1 to ungate all power domains on the digital side.
5. If CM\_KEEP\_ALIVE = 0 and REG\_EN = 0, ensure that CM\_STARTUP\_OVER = 0.
6. If CM\_KEEP\_ALIVE = 0 and REG\_EN = 0, wait 35 ms.
7. Set CM\_STARTUP\_OVER = 1.
8. Set XTAL\_EN = 1 if the crystal is being used.
9. Configure the PLL using CLK\_CTRLx registers and set the XTAL\_EN and PLL\_EN bits if in use.
10. Configure all other setup bits while the PLL is locking (or at any other time after PD = 1).
11. Ensure that all digital power domains are finished powering up, the PLL is locked, and the sequencing is complete by reading the PLL\_LOCK bit in Register 0xC0AB. Verify POWER\_UP\_COMPLETE bit = 1. If this bit is set to 1, proceed further or wait until this bit is set to 1.
12. Ensure that SDSP\_EN and FDSP\_EN = 1 and initialize the static RAMs (SRAMs).
13. Set MASTER\_BLOCK\_EN = 1 to power up all the blocks that are enabled.
14. Set FDSP\_RUN and SDSP\_RUN to 1 for the DSPs to operate.

### EXAMPLE ADC TO DAC POWER-UP

To illustrate the power-on sequencing, an example sequence of register writes (and associated wait times) follows that provides the fastest possible passthrough from ADC0 to DAC0 of the ADAU1788. This sequence assumes a default MCLK input of 24.576 MHz.

- Apply AVDD and IOVDD.
  - Apply DVDD if REG\_EN = 0.
- If REG\_EN = 1, wait 20 ms for DVDD to settle.
- Set POWER\_EN = 1 by writing 0x11 to Register 0xC00D.
- Wait 35 ms for the CM voltage to power up and stabilize.
- While waiting, configure the following registers:
  - Enable ADC0 and DAC0 by writing 0x11 to Register 0xC004.
  - Set DAC0 routing to ADC0 by writing 0x44 to Register 0xC03E.
  - Unmute DAC0 by writing 0x84 to Register 0xC03B.
- After 35 ms have elapsed, set CM\_STARTUP\_OVER = 1 by writing 0x15 to Register 0xC00D.
- Write 0x01 to Register 0xC005 to enable the PLL.

- Set MASTER\_BLOCK\_EN = 1 by writing 0x17 to Register 0xC00D.

The total time from power-up to the ADC0 signal being present on DAC0 is ~80 ms.

### DVDD LDO REGULATOR

There is an LDO voltage regulator that can optionally generate the DVDD supply from the HPVDD supply. If the REG\_EN pin is tied to ground, this regulator disables, and an appropriate DVDD voltage must be supplied externally on the DVDD pin. If the REG\_EN pin is tied to AVDD, the LDO regulator enables and generates the required DVDD voltage.

The DLDO\_CTRL bit determines the voltage of the LDO output. By default, the output is set to 0.9 V.

The LDO requires the CM voltage to operate. Therefore, even if CM\_KEEP\_ALIVE = 1, the CM output remains present if POWER\_EN = 0. Therefore, to achieve the lowest possible power-down power when REG\_EN = 1, set the PD low.

### CLOCK INITIALIZATION

The ADAU1788 can generate its clocks either from an externally provided clock on the BCLK\_0, FSYNC\_0 or MCLKIN pin or from a crystal oscillator. In both cases, the on-board PLL can be used or the clock can be fed directly to the core. When a crystal oscillator is used, the crystal oscillator function must be enabled in the XTAL\_EN and XTAL\_MODE bits. If the PLL is used, it must always be set to output 49.152 MHz. The PLL can be bypassed if a clock of 24.576 MHz is available in the system, which can be accomplished by setting PLL\_BYPASS = 1. Bypassing the PLL saves system power but limits the processing available in the SigmaDSP to the lower clock rate.

#### PLL Enabled Setup

To program the PLL during initialization or reconfiguration of the codec, take the following steps:

1. Ensure that POWER\_EN = 1.
2. Ensure that PLL\_EN = 0.
3. Set the PLL control registers (Register 0xC00E through Register 0xC015).
4. Write 1 to PLL\_UPDATE in Register 0xC016 to propagate the PLL settings.
5. Enable the PLL using the PLL\_EN bit.

Other blocks can be powered up while the PLL is not enabled or locked. However, if the PLL is enabled and not locked, all other circuitry waits until the PLL is locked to begin the power-up sequences.

**Control Port Access During Initialization**

Any control registers can be accessed at any time during initialization, before PLL is enabled, or during PLL lock. To access SigmaDSP memories, SDSP\_EN must be set to 1, and the PLL must be locked, if in use. To access FastDSP memories, FDSP\_EN must be set to 1, and the PLL must be locked, if in use.

**PLL**

The PLL can use any of the BCLK\_0, FSYNC\_0, or MCLKIN signals as a reference to generate the core clock, and the source is selected via the PLL\_SOURCE bits. Depending on the input clock frequency, the PLL must be set for either integer or fractional mode. The PLL can accept input frequencies in the range of 30 kHz to 27 MHz. The PLL output frequency can be set to be between 32 MHz and 50 MHz. All internal sampling rates specified within the data sheet assume a PLL output frequency of 49.152 MHz, which is a 1024 × 48 kHz sample rate. If the PLL output is set at a different frequency, all internal sampling rates adjust accordingly. For example, if the PLL output is set at 32.768 MHz, which is 1024 × 32 kHz, all internal sampling rates must be adjusted by 32 kHz ÷ 48 kHz or 0.667 ratio.

**PLL Bypass Operation**

The chip can function with the PLL disabled if the PLL is bypassed by setting the PLL\_BYPASS bit to 1 and providing a fixed 24.576 MHz clock to the core via the PLL\_SOURCE bits and appropriate MCLKIN/BCLK\_0 pin. All blocks operate the same in PLL bypass mode except the SigmaDSP, which runs at half speed relative to the PLL being on and, therefore, can only execute half as many instructions.

**Input Clock Divider**

Before reaching the PLL, the input clock signal goes through an integer clock divider to ensure that the clock frequency is within a suitable range for the PLL. The PLL\_INPUT\_PRESCALER bits set the PLL input clock divide ratio.

The input frequency limits of the PLL are specified after this input prescale divider. Therefore, the frequency after division must fall within specified range.

**Integer Mode**

Integer mode is used when the PLL output is an integer multiple of the PLL input clock.

For example, if the PLL input clock = 12.288 MHz and the PLL\_INPUT\_PRESCALER + 1 = 1, the PLL required output = 49.152 MHz. Therefore,  $R = 49.152 \text{ MHz} / 12.288 \text{ MHz} = 4$ , where R is PLL\_INTEGER\_DIVIDER.

Another example is as follows, if PLL input clock = 48 kHz, the PLL required output = 49.152 MHz, then  $R = 49.152 \text{ MHz} / 48 \text{ kHz} = 1024$ .

In integer mode, the values set for N and M are ignored. Figure 51 lists common integer PLL parameter settings for 48 kHz sampling rates.

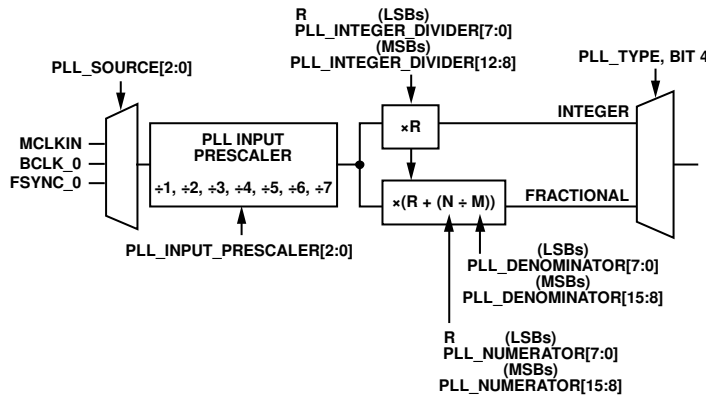

Figure 51. PLL Block Diagram

Table 13. Integer PLL Parameter Settings for PLL Output = 49.152 MHz

PLL Input	Input Prescaler (X)	Integer (R)	Denominator (M)	Numerator (N)
32.768 kHz	0	1500	Don't care	Don't care
48 kHz	0	1024	Don't care	Don't care
12.288 MHz	0	4	Don't care	Don't care
24.576 MHz	0	2	Don't care	Don't care



**Fractional Mode**

Fractional mode is used when the clock input is a fractional multiple of the PLL output.

For example, if MCLKIN = 13 MHz and  $f_s = 48$  kHz, the PLL required output = 49.152 MHz and

$$(R + (N/M)) = 49.152 \text{ MHz}/13 \text{ MHz} = (3 + (1269/1625))$$

where:

$$R = 3.$$

$$N = 1269.$$

$$M = 1625.$$

Table 14 lists common fractional PLL parameter settings for 48 kHz sampling rates. When the PLL is used in fractional mode, it is important that the N/M fraction be kept within the  $0.1 \leq N/M \leq 0.9$  range to ensure correct operation of the PLL.

When used in fractional mode, the input to the PLL after the input divider must be  $\geq 1$  MHz.

**MULTICHIP PHASE SYNCHRONIZATION**

Multiple ADAU1788 devices can be ensured to remain in phase synchronization across the respective audio channels of the devices by setting the SYNC\_SOURCE bit settings to use the same signal that both chips share. SYNC\_SOURCE can be set to derive the phase synchronization signal from FSYNC\_0. If only the shared serial ports between the two ICs are asynchronous to the core clock, then the SYNC\_SOURCE must use the input ASRC. Alternatively, if no serial port is used, an internal synchronization source can be used.

**CLOCK OUTPUT**

A clock output of varying divisions of the PLL output can be generated on any of the MPx pins.

**POWER SUPPLY SEQUENCING**

AVDD, HPVDD, and IOVDD are nominally 1.8 V, and DVDD is set at 0.9 V when using the on-board regulator.

On power-up, AVDD and HPVDD must be powered up before or at the same time as IOVDD. Do not power up IOVDD when power is not applied to AVDD.

Enabling the  $\overline{\text{PD}}$  pin powers down all analog and digital circuits and resets the devices to its default state. Before enabling  $\overline{\text{PD}}$  (that is, setting it low), mute the outputs to avoid any pops when the IC is powered down.

$\overline{\text{PD}}$  can be tied directly to IOVDD for normal operation.

**Power-Down Considerations**

When powering down the ADAU1788, mute or power down the outputs before the power supplies are removed. Otherwise, pops or clicks may be heard.

**Table 14. Fractional PLL Parameter Settings for PLL Output = 49.152 MHz**

PLL Input (MHz)	Input Divider (X + 1)	Integer (R)	Denominator (M)	Numerator (N)
13	1	3	1625	1269
19.2	1	2	25	14

SIGNAL ROUTING

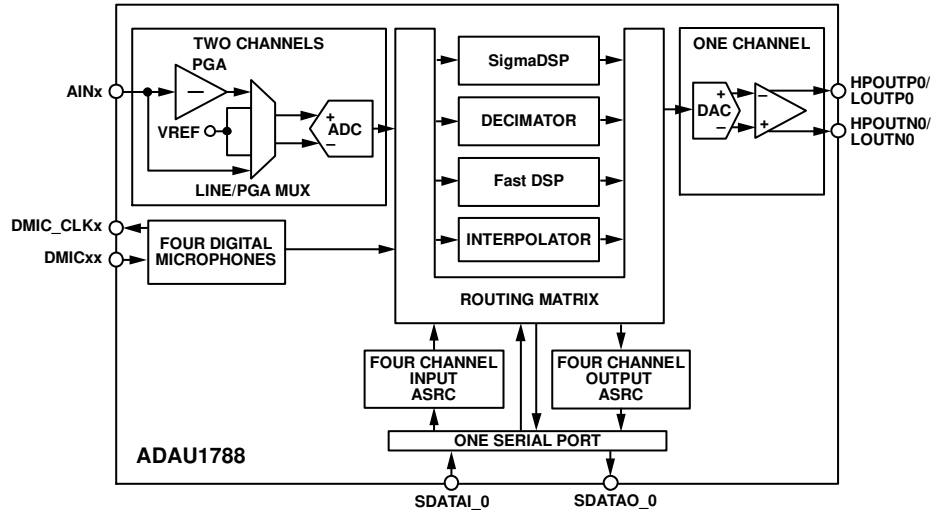

NOTES  
 1. VREF IS THE INTERNAL VOLTAGE REFERENCE.

Figure 52. Input and Output Signal Routing

201934-055

# INPUT SIGNAL PATHS

## ANALOG INPUTS

The ADAU1788 can accept both line level and microphone inputs. Each of the two analog input channels can be configured in single-ended mode or single-ended with PGA mode. There are also inputs for up to four digital microphones. The analog inputs are biased at the CM voltage. Connect unused input pins to the CM pin or ac-couple the pins to ground.

### Phase Difference Various Signal Path ADAU1788

Figure 54 shows the phase variation between various blocks within the ADAU1788. The gray waveform shows the signal path from analog in to digital output or analog output, and the black waveform shows the signal path from digital in to analog output.

There is phase inversion from the analog input and the ADC, and similarly, from the DAC and headphone outputs (see Table 15). However, there is no phase inversion in the digital blocks.

### Input Impedance

The input impedance of the analog inputs varies with the gain of the PGA. This impedance ranges from 0.97 kΩ at the 35.25 dB gain setting to 20.26 kΩ at the 0 dB gain setting. The resistors inside the ADAU1788 are precisely matched to each other,

resulting in very little gain error. However, the exact value of the resistors depends on various conditions in the silicon manufacturing process and can vary by as much as ±20%.

The optional 10 dB PGA boost, set in the PGAx\_BOOST bits, does not affect the input impedance. This setting is an alternative way of increasing gain without decreasing input impedance.

With no PGA or line input mode, the input impedance is fixed at 14.3 kΩ.

### Analog Microphone Inputs

For microphone signals, the ADAU1788 analog inputs can be configured in single-ended with PGA mode. The PGA settings are controlled in Register 0xC021 through Register 0xC029. The PGA is enabled by setting the PGAx\_EN bits.

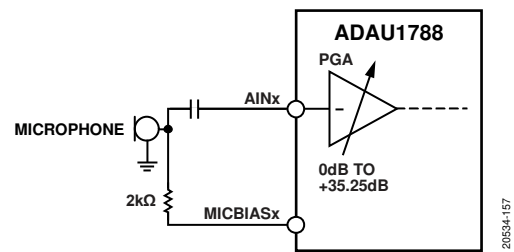

Figure 53. Single-Ended Line Inputs

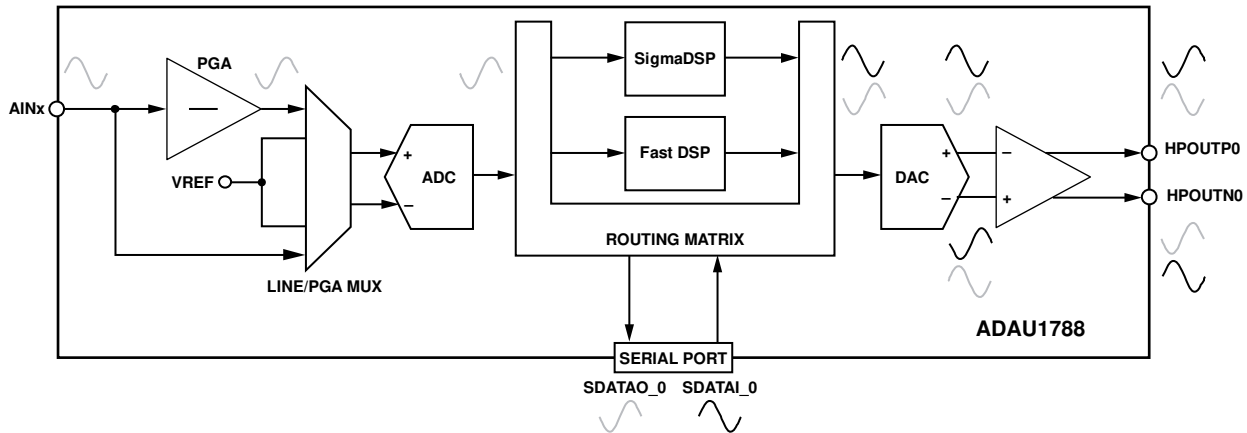

Figure 54. Phase Difference Between Input and Output Inside the ADAU1788

Table 15. Phase Difference Between the Input and Output Various Paths

Signal Path <sup>1</sup>	Phase in Degrees (°) <sup>2</sup>
Analog In to ADC to Digital Output (Serial Port)	180
Analog In to PGA to ADC to Digital Output (Serial Port)	180
Analog In to ADC to DAC to HPOUTP0/HPOUTN0	0
Analog In to PGA to ADC to DAC to HPOUTP0/HPOUTN0	0
Digital In (Serial Port) to DAC to HPOUTP0/HPOUTN0	180

<sup>1</sup> Because there is no phase inversion in any of the digital blocks, adding or removing these blocks from the signal paths does not affect the phase difference except for any filters and/or signal processing blocks used in the DSP.

<sup>2</sup> The phase can also be inverted easily in SigmaDSP or FastDSP using the inversion cell.

### Analog Line Inputs

Line level signals can be input on the AINx pins of the analog inputs. Figure 55 shows a single-ended line input using the AINx pins. When using single-ended line input, the PGA must be disabled using the PGAx\_EN bits.

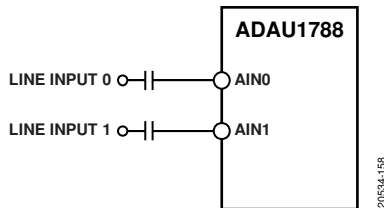

Figure 55. Single-Ended Line Inputs

### Precharging Input Capacitors

Precharge amplifiers are enabled by default to quickly charge large series capacitors on the analog inputs. Precharging these capacitors prevents pops in the audio signal. The precharge circuits are powered up by default when an ADC channel is enabled and remain on for an amount of time determined by the ADC\_AIN\_CHRG\_TIME bits register control. The internal impedance for the AINx pins is 750  $\Omega$  in this mode. However, at startup, the internal impedance is governed by the time constant of the reference voltage at the CM pin because the input precharge amplifiers use the CM voltage as a reference.

### Microphone Bias

The ADAU1788 includes two microphone bias outputs: MICBIAS0 and MICBIAS1. These pins provide a voltage reference for electret analog microphones. The MICBIASx pins can also cleanly supply voltage to digital or analog MEMS microphones with separate power supply pins. The MICBIASx voltage is set in the microphone bias control register (MBIAS\_CTRL). Using this register, either the MICBIAS0 or MICBIAS1 output can be enabled and disabled. The gain options provide two possible voltages:  $0.65 \times AVDD$  or  $0.9 \times AVDD$ .

Many applications require enabling only one of the two bias outputs. Enable the two bias outputs when multiple microphones are used in the system or when the positioning of the microphones on the PCB does not allow one pin to bias all microphones.

### PGAs

The PGAs have a programmable gain from 0 dB to 35.25 dB. The gain is controlled via the PGAx\_GAIN registers. The gain can be increased by 10 dB by setting the PGAx\_BOOST register to 1.

The slew between gain steps is performed automatically when the PGAx\_SLEW\_DIS register is 0. When the PGAx\_SLEW\_DIS register is set to 1, the slew can be performed manually with the 5 LSBs of the PGAx\_GAIN register. These bits are intended only for controlling smoother transitions between the 0.75 dB steps of the 6 MSBs (PGAx\_GAIN[10:5]) and must only be set to a 0 when not transitioning the gain.

### DIGITAL MICROPHONE INPUTS

When using a digital microphone connected to the DMIC01 and DMIC23 pins, the corresponding DMICx\_EN registers must be set to enable the digital microphone signal paths. The digital microphone channels can be swapped (left/right swap) by writing to the DMICxx\_EDGE bits.

The digital microphone inputs are clocked from the DMIC\_CLK0 or DMIC\_CLK1 pins. The digital microphone data stream must be clocked by these pins and not by a clock from another source, such as another audio IC. The frequency of each DMIC\_CLK output can be set individually via the DMIC\_CLKx\_RATE bits. Each digital microphone data input pin must be mapped to the corresponding DMIC\_CLKx via the DMICxx\_MAP registers.

Each digital microphone input pair has separate sample rate controls that determine the downsampling ratio. These controls are set via the DMICxx\_FS bits. The output sample rate can be set between 12 kHz and 768 kHz. The initial decimation filter order can be selected between fourth- or fifth-order via the DMICxx\_DEC\_ORDER bits. The fourth-order selection yields the lowest propagation delay, and the fifth-order selection may be needed to maintain full performance with some high dynamic range microphones. The DMICxx\_FCOMP bits control whether or not the high frequency roll-off of the decimation filter is compensated for. No compensation gives the lowest propagation delay but slight attenuation in the pass-band. There are separate digital volume controls and 1 Hz high-pass filters for each digital microphone channel.

The input pulse density modulation (PDM) is mapped directly to the relative pulse code modulation (PCM) full-scale. For example, a 50% PDM density input generates a  $-6$  dBFS output with a volume control setting of 0 dB.

The digital microphone signals and the ADCs are completely independent and do not share decimation filters.

### Digital Microphone Volume Control

The volume setting of each digital microphone channel can be digitally attenuated in the DMIC\_VOLx registers. The volume can be set between +24 dB and -71.25 dB in 0.375 dB steps. The digital microphone volume can also be digitally muted in the DMICx\_MUTE bits. By default the volume control performs a soft ramp when changed, which can be bypassed for instantaneous change of volume via the DMIC\_HARD\_VOL bit. The volume control for every channel can be set to use the Channel 0 volume via the DMIC\_VOL\_LINK bit. When a digital microphone channel is enabled, it starts immediately at the volume level set by its DMIC\_VOLx register. When a digital microphone channel is disabled, it disables immediately and does not wait to ramp down the volume.

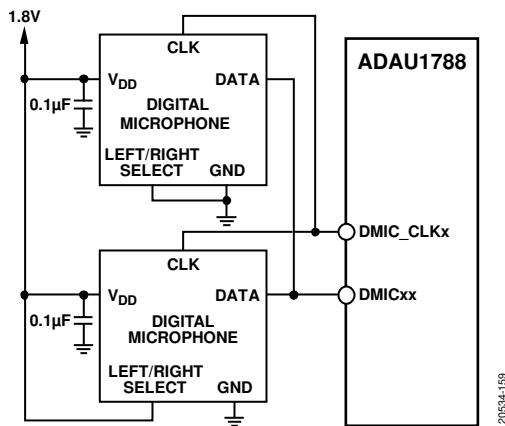

Figure 56. Digital Microphone Interface Block Diagram

### ADCs

The ADAU1788 includes two 24-bit,  $\Sigma$ - $\Delta$  ADCs with a selectable sample rate of 12 kHz to 768 kHz.

#### ADC Full-Scale Level

The full-scale input to the ADCs (0 dBFS) is nominally 0.49 V rms. Signal levels above the full-scale value cause the ADCs to clip.

#### Digital ADC Volume Control

The volume setting of each ADC can be digitally attenuated in the ADCx\_VOL registers. The volume can be set between +24 dB and -71.25 dB in 0.375 dB steps. The ADC volume can also be digitally muted in the ADCx\_MUTE bits. By default, the volume control performs a soft ramp when changed, which can be bypassed for instantaneous change of volume via the ADC\_HARD\_VOL bit. The volume control for every channel can be set to use the Channel 0 volume via the ADC\_VOL\_LINK bit. When an ADC channel is enabled, it starts immediately at the volume level set by its ADCx\_VOL register. When an ADC channel is disabled, it disables immediately and does not wait to ramp down the volume.

#### Filtering

A high-pass filter is available on the ADC path to remove dc offsets. This filter can be enabled or disabled by using the ADCx\_HPF\_EN bits. The corner frequency of this high-pass filter is set to 1 Hz.

The ADC01\_FCOMP bits control whether the high frequency roll-off of the decimation filter is compensated for or not. No compensation gives the lowest propagation delay but with slight attenuation in the pass-band.

## OUTPUT SIGNAL PATHS

Data can be routed to the output DAC path from the serial ports, the SigmaDSP core, the Fast DSP core, the ADCs, the digital microphones, or the input ASRCs.

The analog output pins are capable of driving headphone or earpiece speakers. The line outputs can drive a load of at least 10 k $\Omega$  or can be put into headphone mode to drive headphones or earpiece speakers. The analog output pins are biased at the CM voltage.

### ANALOG OUTPUTS

#### Headphone Output

The headphone output is differential. There is one differential output available at HPOUTP0 and HPOUTN0. The output pins can be set as a headphone driver by setting the HP0\_MODE bit to 1 in the HP\_CTRL register (Register 0xC040). The headphone output can drive a minimum load of at least 10  $\Omega$ . To mute or unmute the headphone output, use the DAC0\_MUTE bits (Register 0xC03B).

#### Line Output

Set the output to line output mode by setting the HP0\_MODE bit to 0. The analog output pins (HPOUTP0/LOUTP0 and HPOUTN0/LOUTN0) can drive differential loads of  $\geq 10$  k $\Omega$ . By default, these pins are set to line output mode. To mute or unmute the line output, use the DAC0\_MUTE bit.

#### Pop and Click Suppression

To avoid clicks and pops, mute the analog output that is in use while changing any register settings that may affect the signal path. This output can then be unmuted after the changes have been made.

### DAC

The ADAU1788 includes one 24-bit,  $\Sigma$ - $\Delta$  DAC. This converter can operate with input sampling frequencies of 12 kHz, 24 kHz, 48 kHz, 96 kHz, 192 kHz, 384 kHz, or 768 kHz. The sample rate is selectable via the DAC\_FS bit. Ensure that channels routed to the DAC are at the same sample rate.

There are two power options that trade off performance for lower power consumption in the DAC. DAC\_LPM mode can set the DAC to run at a reduced oversampling ratio. The DAC\_IBIAS control lowers the bias current to the DAC.

#### DAC Full-Scale Level

The full-scale output from the DAC (0 dBFS) is nominally 1 V rms for a differential output.

#### Digital DAC Volume Control and Filtering

The volume of the DAC channel can be digitally attenuated using the DAC0\_VOL registers. The volume can be set to be between +24 dB and -71.25 dB in 0.375 dB steps. The DAC volume can also be digitally muted in the DAC0\_MUTE bits. By default, the volume control performs a soft ramp when changed, which can be bypassed for instantaneous change of volume via the DAC\_HARD\_VOL bit. When a DAC channel is enabled, it starts at the lowest volume setting and ramps, if DAC\_HARD\_VOL = 0, to the volume level set by the corresponding DAC0\_VOL register. When a DAC channel is disabled, it ramps the volume from its current setting, if DAC\_HARD\_VOL = 0, to mute and then turns off.

A high-pass filter is available on the DAC path to remove dc offsets. This filter can be enabled or disabled using the DAC0\_HPF\_EN bits. The corner frequency of this high-pass filter is set to 1 Hz.

The DAC linear interpolation filter can be selected via the DAC\_MORE\_FILT bit in Register 0xC03A. Setting DAC\_MORE\_FILT = 0 results in lower propagation delay at the expense of lower attenuation of out of band components.

## PDM OUTPUTS

The ADAU1788 includes two channels of high performance, 1-bit PDM outputs suitable for driving an external amplifier or other peripheral with low latency. These PDM outputs can operate with input sampling frequencies of 12 kHz, 24 kHz, 48 kHz, 96 kHz, 192 kHz, 384 kHz, or 768 kHz. The sample rate is selectable via the PDM\_FS bit. Ensure that all channels routed to the PDM outputs are at the same sample rate.

The PDM output modulators can run either at 3.072 MHz or 6.144 MHz, which is selected via the PDM\_RATE bit. This bit also determines the rate of the PDM output clock.

The PDM output is sent over a 2-wire (PDM clock and PDM data) dual data rate interface. These two signals can be routed to any multipurpose (MPx) pin output via the respective MPx\_MODE bits for each pin.

### ***PDM Outputs Full-Scale Level***

The full-scale PDM input results in the full-scale PDM outputs. The PDM modulator performance reduces at an output amplitude greater than  $-7.5$  dBFS.

### ***PDM Outputs Volume Control and Filtering***

The volume of each PDM channel can be digitally attenuated using the PDM\_VOLx registers. The volume can be set to be between  $+24$  dB and  $-71.25$  dB in  $0.375$  dB steps. The PDM volume can also be digitally muted in the PDMx\_MUTE bits. By default, the volume control performs a soft ramp when changed, which can be bypassed for instantaneous change of volume via the PDM\_HARD\_VOL bit. The volume control for both channels can be set to use the Channel 0 volume via the PDM\_VOL\_LINK bit. When a PDM channel is enabled, it starts at the lowest volume setting and ramps, if PDM\_HARD\_VOL = 0, to the volume level set by its PDM\_VOLx register. When a PDM channel is disabled, it ramps the volume from its current setting, if PDM\_HARD\_VOL = 0, to mute and then turn off.

A high-pass filter is available on the PDM path to remove dc offsets. This filter can be enabled or disabled by using the PDMx\_HPF\_EN bits. The corner frequency of this high-pass filter is set to 1 Hz.

The order of the final interpolation filter can be selected via the PDM\_MORE\_FILT bit. Selecting the lower order filter results in lower propagation delay at the expense of lower attenuation of out of band components.

## ASRCs

The ADAU1788 includes ASRCs to enable asynchronous full-duplex operation of the serial port. Four channels of ASRC are available for the digital outputs, and four channels of ASRC are available for the digital input signals.

The ASRCs can convert serial output data from the internal rate of up to 192 kHz back down to less than 8 kHz. All intermediate frequencies and ratios are also supported.

Each channel of the input ASRC can select its source from any of the 16 channels on the serial audio port via the ASRCIx\_ROUTE bits. The output (internal) sample rate of the input ASRC is set via the ASRCI\_OUT\_FS bit.

The output ASRC channels can receive their inputs from many internal sources via the ASRCOx\_ROUTE bits. Ensure that the sample rate of all sources to all of the channels of the output ASRC are at the same sample rate. The source of Channel 0 determines the internal sample rate of the output ASRC. The source of the channels to the output ASRC are set via the ASRCOx\_ROUTE bits.

The ASRCs automatically mute their outputs to zero data when the outputs are not locked. The state of each ASRC lock can be monitored via the ASRCI\_LOCK and ASRCO\_LOCK read only status bits. In addition, unlocked to locked or locked to unlocked transitions of each ASRC can be used as an interrupt source to the two interrupt controllers.

By default, the ASRCs use the high performance mode of operation. A lower power, lower performance mode of operation can be enabled via each ASRCs ASRCx\_LPM bit control.

Additional filtering options are available to further customize the ASRCs to any application. Each ASRC has a ASRCx\_VFILT bit that can enabled a voice band filter that provides additional rejection at the Nyquist frequency, which can be useful when using traditional voice band sampling frequencies. There is also an ASRCx\_MORE\_FILT control bit for each ASRC that provides additionally filtering of out of band energy and may improve performance in some conditions.

### INTERPOLATION AND DECIMATION BLOCKS

The ADAU1788 includes blocks designed to convert audio from the fast sampling rate used for noise cancelling and the slow audio rate of the audio source. There are eight channels of fast to slow decimation and eight channels of slow to fast interpolation.

Every two channel pairs of each block can independently operate at different input and output rates than the other two channel pairs. Ensure that the sampling rate of each two channel pair inputs matches when selecting the inputs via the routing register controls. The input sampling rates are determined by the FDECxx\_IN\_FS and FINTxx\_IN\_FS bits and the output

sampling rates are determined by the FDECxx\_OUT\_FS and FINTxx\_OUT\_FS bits. For the interpolation block, the output rate must be set higher than the input rate. For the decimation block, the output rate must be set lower than the input rate.

### SIGNAL LEVELS

Full-scale digital or 0 dBFS maps to the analog full-scale of the various converters. The SigmaDSP and FastDSP cores can maintain up to 24 dBFS internally but clip symmetrically to 0 dBFS at their outputs. By default, there is no gain adjustment between any block.



## FastDSP CORE

The ADAU1788 FastDSP core is optimized for ANC processing. The processing capabilities of the core include biquad filters, limiters, expanders, multipliers, bit wise operations, clippers, volume controls, and weighted mixing. The core has inputs from all sources and sixteen outputs. The core is controlled with a 27-bit program word, with a maximum of 64 instructions per frame.

### INSTRUCTIONS

A complete list of instructions and processing blocks can be found in the [SigmaStudio](#) software for the ADAU1788. The available instructions include the following:

- Single precision (27-bit fractional precision) biquad/second-order filters
- Double precision (54-bit fractional precision) biquad/second-order filters
- Lower precision (19-bit fractional precision) biquad/second-order filters
- Two to four input addition
- T connection in [SigmaStudio](#)
- Limiter with/without external detector loop or side chain input
- Expander with/without external detector loop or side chain input
- Linear gain
- Volume slider
- Mute
- Two input multiply
- Two to four input scale and mix
- Symmetrical clipper
- Absolute value
- Shift
- OR, AND, XOR, and INV
- Memory read or write

### FILTER PRECISION

Different levels of fractional precision are available for filters in the FastDSP core. Using lower fractional precision results in lower power consumption than using higher precision. However, care must be taken to ensure that filters have enough precision to maintain stability.

### FLAGS AND CONDITIONAL EXECUTION

Several flags can be set or not set on a per instruction basis. These flags are set based on the output of that instruction. These flags include the following:

- Output equals zero
- Output is not equal to zero
- Output is greater than zero
- Output is less than zero
- Output is greater than or equal to zero

- Output is less than or equal to zero
- Accumulator overflow

Each instruction can always execute or conditionally execute based on an individual flag or other states. The other states include the following:

- The logic state of MPx pins (MP0 to MP10), if used as GPIOs. The state of the output MPx pin can be set in Register 0xC092 and Register 0xC093 or SigmaDSP.
- The FDSP\_REG\_COND0 to FDSP\_REG\_COND7 bits are set high or low.
- The Modulo N counter equals zero.

The GPIOs can be used on any unused MPx pins. The state of the MPx pins used as GPIOs determines whether or not an instruction executes.

The FDSP\_REG\_CONDX bits are read/write bits that can be accessed via any of the control interfaces or via the SigmaDSP. The state of these registers determines whether or not an instruction executes.

The Modulo N counter is a counter that increments every frame of the FastDSP. The counter is reset to 0 after the number of frames is set in the FDSP\_MOD\_N bit. Instructions can execute every N frames set by the FDSP\_MOD\_N bit, which provides a mechanism to easily run some instructions at a lower rate than the frame rate.

When an instruction does not execute based on a condition, the instruction can be set to either do nothing or pass its input to its output.

### INPUT SOURCES

Any instruction can use any of the following as an input source: any data register, any accumulator register, any serial port input channel, any digital microphone input, any ADC input, any SigmaDSP output, any ASRCI channel, or any output from the interpolation block.

The frame rate of the FastDSP must be set and determines when the program counter starts counting again at 0, which must be set to the sample rate of the fastest source. The source that the frame rate is determined by is set via the FDSP\_RATE\_SOURCE bits. If desired, the frame rate can be set independent of any source, and the rate can be set via the FDSP\_RATE\_DIV bits.

**POWER AND RUN CONTROL**

All program, parameter, and data memories for the FastDSP can be read or written from any control interface or the SigmaDSP when POWER\_EN = 1, FDSP\_EN = 1, and the PLL is locked, if in use.

A single register FDSP\_EN powers up the FastDSP core to allow access to the memories. The FastDSP core starts processing when both FDSP\_EN = 1 and FDSP\_RUN = 1.

**DATA MEMORY**

The ADAU1788 FastDSP datapath is 28 bits (5.23 format) and up to 24 dBFS is allowed. All inputs and outputs to FastDSP are 24 bits (1.23 format). The outputs are truncated to 24 bits so >0 dBFS on an output results in clipping. The data memory is 64 words. The double length memory enables the core to perform double precision arithmetic with double length data and single length coefficients.

Each instruction has four associated data/state memory locations. These locations can read at any time via the I<sup>2</sup>C or SPI or from the SigmaDSP.

**PARAMETERS**

Parameters, such as filter coefficients, limiter settings, and volume control settings, are saved in parameter memories. Each parameter is a 32-bit number. The format of this number depends on the associated instruction. The number formats of the different parameters are shown in Table 16 for the biquad instructions. When the parameter formats use less than the full 32-bit memory space, as with the limiter parameters, the data is LSB aligned.

**Table 16. Parameter Number Format**

Parameter Type	Format
Filter Coefficient (B0, B1, B2, A1, A2)	5.27

There are three parameter banks available. Each bank can hold a full set of 320 parameters (64 filters × 5 coefficients). Users can switch between Bank A, Bank B, and Bank C, allowing three sets of parameters to be saved in memory and switched on-the-fly while the core is running. Bank switching can be achieved by writing to the FDSP\_BANK\_SEL bits. Parameters in the active bank must only be updated via the FastDSP safeload registers while the core is running. If parameters are not updated in this way, a bad output likely results.

Parameters are assigned to instructions in the order in which the instructions are instantiated in the code.

**PARAMETER BANK SWITCHING**

Three banks of parameters are available: A, B, and C. At any given time, the FastDSP uses only one of these banks. The three banks allow coefficients for filters and variables for other instructions to easily be switched between different processing scenarios. The bank used is selected with the FDSP\_BANK\_SEL bits.

When the current bank is changed, the parameter values used for processing can either be changed on the next frame start or ramped via linear interpolation between the previously selected bank and the new bank indicated via the FDSP\_BANK\_SEL bits. To select this change or ramp, use the FDSP\_RAMP\_MODE bit. When the linear parameter ramp mode is selected, only the parameters associated with the three biquad instructions ramp. All parameters associated with other instructions change at the beginning of the next frame. Parameters in banks that are actively ramping do not change during a bank switch.

It is possible to stop the linear ramp of parameters between the two values in the previous and current bank. The FDSP\_LAMBDA bits are a 6-bit value representing the point along the linear interpolation curve between the two banks at which the bank ramp switch stops. The lambda value can be updated on-the-fly via the control interfaces but only increased after a ramped bank switch is initiated. To complete a bank switch, set a value of 63 (default setting). The actual current ramp point (0 to 63) can be read via the FDSP\_CURRENT\_LAMBDA bits. When this value reaches 63, the bank switch is complete, and the current parameters used match the current bank. Parameters in the two banks being ramped between cannot be modified while a ramped bank switch is occurring.

An interrupt can be triggered to either interrupt controller via the IRQx\_PRAMP interrupt source bits. This interrupt triggers on the first frame when a ramped bank switch is active and FDSP\_CURRENT\_LAMBDA equals FDSP\_LAMBDA.

The rate at which the ramp between the two banks occurs is selectable via the FDSP\_RAMP\_RATE bits.

**PARAMETER BANK COPYING**

The parameters of any bank can be copied to any other bank with a single control write. There are six registers, FDSP\_COPY\_xx, for the six possible bank copy operations. Writing a 1 to one of these bits initiates a bank copy. After a bank copy initiates, the FastDSP waits until the start of the next frame, and then during the next frame copies the content of the banks while the associated instruction is executing. The bank copy completes at the start of the subsequent frame and takes at most two frames to complete from the initiation. Copying to the active bank is not permitted but results in no action being taken.

Table 17. Memory Addressing for FastDSP Core

Memory	Memory Size	Word Size	Base Address (Decimal)	Base Address (Hexadecimal)
Program	64	32	8192	0x2000
Bank A Parameter 0	64	32	8256	0x2040
Bank A Parameter 1	64	32	8320	0x2080
Bank A Parameter 2	64	32	8384	0x20C0
Bank A Parameter 3	64	32	8448	0x2100
Bank A Parameter 4	64	32	8512	0x2140
Bank B Parameter 0	64	32	8576	0x2180
Bank B Parameter 1	64	32	8640	0x21C0
Bank B Parameter 2	64	32	8704	0x2200
Bank B Parameter 3	64	32	8768	0x2240
Bank B Parameter 4	64	32	8832	0x2280
Bank C Parameter 0	64	32	8896	0x22C0
Bank C Parameter 1	64	32	8960	0x2300
Bank C Parameter 2	64	32	9024	0x2340
Bank C Parameter 3	64	32	9088	0x2380
Bank C Parameter 4	64	32	9152	0x23C0
State 0 (A1 High)	64	32	9216	0x2400
State 1 (A2 High)	64	32	9280	0x2440
State 2 (A1 Low)	64	32	9344	0x2480
State 3 (A2 Low)	64	32	9408	0x2400

## PARAMETER MEMORY ACCESS

Reads from any parameter memory bank from the I<sup>2</sup>C, SPI, or SigmaDSP are unrestricted if the FastDSP core is enabled but not running. Reads of unused parameter banks from the I<sup>2</sup>C, SPI, or SigmaDSP are unrestricted if the FastDSP core is enabled and running. While the core is running, if the I<sup>2</sup>C, SPI, or SigmaDSP try to access the same location on the same cycle, the SigmaDSP has priority, and the read from the I<sup>2</sup>C or the SPI returns all 0s.

Direct reads of in use banks from the I<sup>2</sup>C or the SPI, mREAD instruction, or SigmaDSP are not allowed and return 0s. A read of the current bank returns all 0s. Writes to all parameter banks are possible when the FastDSP core is enabled but not running. Writes to unused banks are possible at any time. While the core is running, if the I<sup>2</sup>C, SPI, or SigmaDSP try to write to the same location on the same cycle, the SigmaDSP has priority, and the write from the I<sup>2</sup>C or the SPI does not occur.

## FastDSP PARAMETER SAFELOAD

The parameter memory for a single instruction can be updated in real time on the active bank via the safeload mechanism over the control interface. Set the instruction number in the FDSP\_SL\_ADDR register, set the parameter values in the FDSP\_SL\_Py\_x registers, and write a 1 to the FDSP\_SL\_UPDATE register. After these settings and write occur, all parameters for that instruction are updated at the same time with the values in the FDSP\_SL\_Py\_x registers at the beginning of the next frame.

There is a second FastDSP safeload interface that is mapped to the data memory space of the SigmaDSP, which allows the SigmaDSP to have word addressable access.

## SigmaDSP CORE

The ADAU1788 has an integrated SigmaDSP core that provides audio signal processing functions for improving the performance of the playback system. The signal processing flow is designed using the [SigmaStudio](#) programming environment, which allows graphical schematic entry and real-time control of all signal processing functions and registers.

The SigmaDSP core does not begin a processing frame until it receives a go signal from the go source. The go signal is sent to the SigmaDSP after the signal is present at the go source. Set the go source by using the SDSP\_RATE\_SOURCE bits. Set the SDSP\_RUN bit to 1 to enable the SigmaDSP core to run after it receives a go signal.

By default, with SDSP\_SPEED = 0, the core runs at 24.576 MHz, giving 512 cycles of processing per each 48 kHz sample period. With SDSP\_SPEED = 1, the core runs at 49.152 MHz, giving 1022 cycles of processing at 48 kHz.

### SIGNAL PROCESSING DETAILS

Standard library algorithms perform fixed point calculations in either 28-bit single precision or 56-bit double precision. The input and output word lengths of the DSP core are 24 bits, but the signals inside the core are extended automatically to 28 bits to create processing headroom. This headroom allows internal gains of up to 24 dB without clipping. Additional gains can be achieved by initially scaling down the input signal in the DSP signal flow. The DSP core output is 24 bits. Therefore, linear scaling, compression, or limiting may be necessary to prevent clipping on the output.

The DSP core consists of a simple 56-bit multiply accumulate (MAC) unit with two sources: data and coefficient. The data source can come from the data RAM, a read only memory (ROM) table of commonly used constant values, or the audio inputs to the core. The coefficient source can come from the parameter RAM or from a ROM table of commonly used constant values.

The two sources are multiplied in a 28-bit fixed point multiplier and the signal is then input to the 56-bit adder. The result is stored in one of three 56-bit accumulator registers. The accumulators can be output from the core in 28-bit format or can optionally be written back into the data or parameter RAMs.

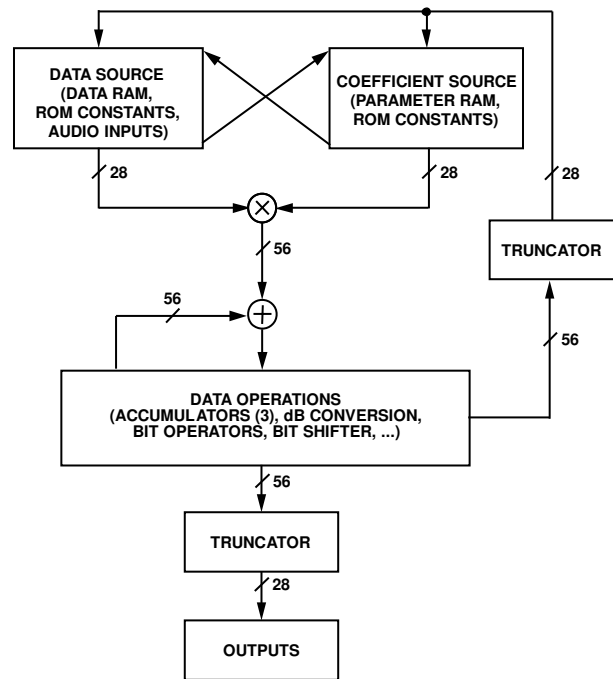

Figure 57. Simplified DSP Core Architecture

20534-063

### Program Counter

The execution of instructions in the core is governed by a program counter, which sequentially steps through the addresses of the program RAM. The program counter starts every time a start pulse signal is received. The start pulse signal occurs every time a new audio sample is received by the functional block, generating the start pulse. The source of the start pulse is selected by the SDSP\_RATE\_SOURCE control bits.

[SigmaStudio](#) inserts a jump to start command at the end of every program. The program counter increments sequentially until the counter reaches the jump to start command and then jumps to the program start address and waits for the next audio frame to clock into the core.

### Watchdog

The SigmaDSP watchdog is a feature that monitors the amount of instructions used in the DSP and checks against an instruction limit set by the user. If the amount of instructions that are executed in the DSP exceeds this limit, the watchdog can notify other ICs in the system via an MPx pin.

Enable the watchdog via the SDSP\_WDOG\_EN bit in the SDSP\_CTRL3 register. Set the value using the SDSP\_WDOG\_VAL bits in the SDSP\_CTRL4 through SDSP\_CTRL6 registers.

The SigmaDSP watchdog error is reported in DSP\_STATUS register (Register 0xC0AE).

**Features**

The SigmaDSP core architecture is designed specifically for audio processing and, therefore, includes several features that maximize processing efficiency. Hardware accelerators, such as decibel conversion, trigonometric tables, and audio specific ROM constants provide improved processing power and simplified algorithm coding.

**Numeric Formats**

DSP systems commonly use a standard numeric format. Fractional numeric systems are specified by an AB format, where A is the number of bits to the left of the decimal point, and B is the number of bits to the right of the decimal point.

The ADAU1788 uses the Numeric Format 5.23 for both the parameter and data values.

**Numeric Format 5.23**

The linear range of the ADAU1788 numeric format is  $-16.0$  to  $+16.0 - 1$  LSB.

For example,

- 1000 0000 0000 0000 0000 0000 0000 =  $-16.0$
- 1110 0000 0000 0000 0000 0000 0000 =  $-4.0$
- 1111 1000 0000 0000 0000 0000 0000 =  $-1.0$
- 1111 1110 0000 0000 0000 0000 0000 =  $-0.25$
- 1111 1111 0011 0011 0011 0011 0011 =  $-0.1$
- 1111 1111 1111 1111 1111 1111 1111 =  $+1$  LSB below 0
- 0000 0000 0000 0000 0000 0000 0000 =  $+0$
- 0000 0000 1100 1100 1100 1100 1101 =  $+0.1$
- 0000 0010 0000 0000 0000 0000 0000 =  $+0.25$
- 0000 1000 0000 0000 0000 0000 0000 =  $+1.0$
- 0010 0000 0000 0000 0000 0000 0000 =  $+4.0$
- 0111 1111 1111 1111 1111 1111 1111 =  $+16.0 - 1$  LSB

The serial port accepts up to 24 bits on the input and is sign extended to the full 28 bits of the DSP core.

**Programming**

On power-up, the ADAU1788 must be configured with a clocking scheme and then loaded with register settings. After the codec signal path is set up, the DSP core can be programmed. With a 48 kHz sample rate, the internal clock rate is 49.152 MHz, resulting in 1024 instruction cycles per audio sample rate.

The device can be programmed using the SigmaStudio graphic tool provided by Analog Devices. No knowledge of writing line level DSP code is required. More information about SigmaStudio is available at [www.analog.com/SigmaStudio](http://www.analog.com/SigmaStudio).

**READ/WRITE DATA FORMATS**

The read/write formats of the control port are byte oriented to allow ease of programming of common microcontrollers. To fit the data into a byte oriented format, 0s are added to the data fields before the MSB to extend the data-word to a full 8 bits. For example, 28-bit words written to the parameter RAM are preceded by four leading 0s to create a 32-bit (4-byte) word, and 39-bit words written to the program RAM are preceded by one leading 0 to create a 40-bit (5-byte) word. These zero padded data fields are appended to a 3-byte field that consists of a 7-bit chip address, a read/write bit, and a 16-bit RAM/register address. The control port knows how many data bytes to expect based on the address given in the first three bytes.

The total number of bytes for a single location write command can vary from one byte (for a control register write) to five bytes (for a program RAM write). Use burst mode to fill the contiguous register or RAM locations. A burst mode write begins by writing the address and data of the first RAM or register location to be written to. Rather than ending the control port transaction (by issuing a stop command in I<sup>2</sup>C mode or by bringing the SS signal high in SPI mode after the data-word), as in a single-address write, the next data-word can be written immediately without specifying its address. The ADAU1788 control port auto-increments the address of each write even across the boundaries of the different RAMs and registers. Burst mode is outlined in the respective control port sections.

**SOFTWARE SAFELOAD**

To update parameters in real time while avoiding pop and click noises on the output, the ADAU1788 uses a software safeload mechanism. The software safeload mechanism enables the SigmaDSP core to load new parameters into the RAM while guaranteeing that the parameters are not in use. The use of this mechanism prevents an undesirable condition where an instruction executes with a mix of old and new parameters.

[SigmaStudio](#) sets up the necessary code and parameters automatically for new projects. The safeload code, along with other initialization codes, fills the first 39 locations in the program RAM. The first eight parameter RAM locations (Address 0x0000 to Address 0x0007) are configured by default in [SigmaStudio](#) as described in Table 18.

**Table 18. Software Safeload Parameter RAM Defaults**

Address (Hex)	Function
0x0000	Modulo RAM size
0x0001	Safeload Data 1
0x0002	Safeload Data 2
0x0003	Safeload Data 3
0x0004	Safeload Data 4
0x0005	Safeload Data 5
0x0006	Safeload target address (offset of -1)
0x0007	Number of words to write/safeload trigger

Address 0x0000, which controls the modulo RAM size, is set by [SigmaStudio](#) and is based on the dynamic address generator mode of the project.

Parameter RAM Address 0x0001 to Address 0x0005 are the five data slots for storing the data for safe loading. The safeload parameter space contains five data slots by default because most standard signal processing algorithms have five parameters or less.

Address 0x0006 is the safeload target address in the RAM (with an offset of -1) parameter, which designates the first address to be written. If more than one word is written, the address increments automatically for each data-word. Up to five sequential parameter RAM locations can be updated with safeload during each audio frame. The target address offset of -1 is used

because the write address is calculated relative to the address of the data, which starts at Address 0x0001. Therefore, to update a parameter at Address 0x000A, the target address is 0x0009.

Address 0x0007 designates the number of words to be written to the RAM parameter during the safeload. A biquad filter uses all five safeload data addresses. A simple mono gain cell uses only one safeload data address. Writing to Address 0x0007 also triggers the safeload write to occur in the next audio frame.

The safeload mechanism is software based and executes once per audio frame. Therefore, take care when designing the communication protocol. A delay equal to or greater than the sampling period (the inverse of sampling frequency) is required between each safeload write. A sample rate of 48 kHz equates to a delay of at least 21 μs. If this delay is not observed, the downloaded data is corrupted.

**FastDSP SAFELOAD**

There are five memory locations mapped to the data memory of the SigmaDSP that can be used to update the current bank parameters of a single instruction of the FastDSP.

The functionality of this is the same as the functionality of the FastDSP safeload via the control port (refer to the FastDSP Parameter Safeload section). The difference is that the parameters can be addressed on a 32-bit word basis, making the writes more efficient than reusing the control port fast load mechanism that is byte addressable. The parameters are also written to the FastDSP as soon as the frame executes, without needing to write a trigger bit. Table 19 lists the SigmaDSP assembler names for the functions used for safeload.

**Table 19. SigmaDSP Safeload to the FastDSP Current Bank**

Name	Function
FDSP_SL_ADDR	FastDSP safeload instruction number
FDSP_SL_P0	FastDSP Safeload Parameter B0
FDSP_SL_P1	FastDSP Safeload Parameter B1
FDSP_SL_P2	FastDSP Safeload Parameter B2
FDSP_SL_P3	FastDSP Safeload Parameter A1
FDSP_SL_P4	FastDSP Safeload Parameter A2

## PROGRAM RAM, PARAMETER RAM, AND DATA RAM

The ADAU1788 address space encompasses a set of registers and three RAMs: program, parameter, and data. Table 20 shows the RAM map. The memory map from the perspective of the SigmaDSP is different than the mapping of the memories to the external control interface because internally within the SigmaDSP each word has its own address, while over the control interface, each byte has its own address. Additionally, the mapping of the memories to the external control interface is offset.

The program RAM and parameter RAM are not initialized on power-up and are in an unknown state until the RAMs are written to.

### PROGRAM RAM

The program RAM contains the 39-bit operation codes that are executed by the core. The [SigmaStudio](#) compiler calculates the instructions executed per frame for a given program and generates an error when this number exceeds the maximum allowable instructions per frame based on the sample rate of the signals in the core.

Because the end of a program contains a jump to start command, the unused program RAM space does not need to be filled with no operation (NOP) commands.

### PARAMETER RAM

The parameter RAM is 28-bits wide and occupies Address 0 (0x0000) to Address 1023 (0x3FFF). The data format of the parameter RAM is twos complement, 5.23, which means that the coefficients can range from +16.0 (minus 1 LSB) to -16.0, with 1.0 represented by the binary word 0000 1000 0000 0000 0000 0000 0000 or by the hexadecimal word 0x00 0x80 0x00 0x00.

The parameter RAM can be written to directly or with a safeload write. The direct write mode of operation is typically used during a completely new loading of the RAM using burst mode addressing to avoid any clicks or pops in the outputs. Although this mode can be used during program execution, there is no handshaking between the core and the control port, and the parameter RAM is unavailable to the DSP core during control writes, resulting in pops and clicks in the audio stream.

[SigmaStudio](#) automatically assigns the first eight positions to safeload parameters. Therefore, project specific parameters start at Address 0x0008.

The SDSP\_RUN bit (Bit 0, Register 0xC081) must be set to 0 before writing to the parameter RAM.

### DATA RAM

The ADAU1788 data RAM stores audio data-words for processing, as well as certain run-time parameters. [SigmaStudio](#) provides the data and address information for writing to and reading from the data RAM. The ADAU1788 has 2048 words of data RAM available.

The [SigmaStudio](#) compiler manages the data RAM and indicates whether the number of addresses needed in the design exceeds the maximum number available.

**Table 20. RAM SigmaDSP Internal Map and Read/Write Modes**

Memory	Size (Words)	Address Range	Read	Write	Write Modes
Parameter RAM	2048 × 28	0 to 2047 (0x0000 to 0x03FF)	Yes	Yes	Direct, safeload
Program RAM	2048 × 39	3072 to 4095 (0x0C00 to 0x13FF)	Yes	Yes	Direct

## POWER SAVING OPTIONS

The ADAU1788 offers multiple options to save the power in some of the blocks.

### ADC BIAS CURRENT CONTROL

The ADCs provide a mechanism to modify the bias current level used, allowing performance vs. power consumption options for the user. Four possible settings can be set independently for Channel 0 and Channel 1 via the ADC01\_IBIAS. Both low power settings also produce more part to part variation in the performance parameters than normal power mode.

### DAC BIAS CURRENT CONTROL

The DAC provides a mechanism to modify the bias current level used, allowing performance vs. power consumption options for the user. Four possible settings can be set via the DAC\_IBIAS control bit.

### DAC LOW POWER MODES

The DAC offers two separate, selectable low power operating modes, allowing power vs. performance trade-offs when using the DAC. Generally, using the DAC\_LPM = 1 setting provides the same or slightly better performance at slightly lower power consumption.

### PLL BYPASS

Bypassing the PLL saves power. If the 24.576 MHz external clock is available and >25 MIPS operation of the SigmaDSP is not needed, there is no downside to bypassing the PLL.

Table 21 PLL\_IBIAS Power Comparison

PLL_BYPASS	PLL Operation	Relative Power Consumption (mW)
0	Used	0
1	Bypassed	-0.55

Table 22. ADC01\_IBIAS Power and Performance Options

ADC01_IBIAS Setting	Description	Change in Digital Noise Reduction (DNR), A-Weighted (dB)	Change in THD + N Level at 1 kHz (dB)	Change in Power Consumption per ADC Channel (mW)
010	Enhanced performance	0	0	+0.12
000	Normal operation	0	0	0
011	Power saving	-0.7	9	-0.27
001	Extreme power saving	-0.7	11.5	-0.39

Table 23. DAC\_IBIAS Power and Performance Options in Headphone Mode

DAC_IBIAS Setting	Description	Change in DNR, A-Weighted (dB)	Change in THD + N Level at 1 kHz (dB)	Change in Power Consumption (mW)
010	Enhanced performance	0	-1	+0.22
000	Normal operation	0	0	0
011	Power saving	-0.5	+4	-0.51
001	Extreme power saving	-1.0	+7	-0.73

Table 24. DAC Low Power and Performance Options in Line Output Mode

Mode	Relative THD + N at 1 kHz, -6 dB	DNR A-Weighted (dB)	Relative Power (mW)
Default	0 dB	105.5	0
DAC_LPM = 1	0 dB	105.5	-0.041
DAC_LPM_II = 1	8 dB	105.8	-0.058



### SigmaDSP CLOCK SPEED CONTROL

By default, SDSP\_SPEED is set to 0 and the SigmaDSP receives a 24.576 MHz clock. If the PLL is used and SDSP\_SPEED is set to 1, the SigmaDSP receives a 49.152 MHz clock and is able to run twice as many instructions. If this extra processing power is not needed, keeping SDSP\_SPEED = 0 saves power.

**Table 25. SDSP\_SPEED Power Comparison**

SDSP_SPEED	SigmaDSP Clock Rate (MHz)	Relative Power Consumption (mW)
1	49.152	0
0	24.576	-0.076

### ASYNCHRONOUS SAMPLE RATE CONVERTERS LOW POWER MODES

The ASRCs offer two separate, selectable low power operating modes. These modes allow power vs. performance trade-offs when using the ASRCs. Generally, if the data being sourced or sinked to the ASRCs is from or to the ADC or DAC using the ASRCx\_LPM\_II setting provides the lowest power consumption and does not degrade the performance of the converters.

**Table 26. Input ASRC Power and Performance Options for 44.1 kHz to 48 kHz Conversion**

Mode	THD + N at 1 kHz (dB)	THD + N at 20 kHz	DNR AW (dB)	Relative Power per Channel (mW)
Default	123	123	130	0
ASRCI_LPM = 1	120	118	130	-0.041
ASRCI_LPM_II = 1	112	108	130	-0.058

**Table 27. Output ASRC Power and Performance Options for 48 kHz to 44.1 kHz Conversion**

Mode	THD + N at 1 kHz (dB)	THD + N at 20 kHz	DNR AW (dB)	Relative Power per Channel (mW)
Default	123	123	130	0
ASRCO_LPM = 1	120	118	130	-0.045
ASRCO_LPM_II = 1	112	108	130	-0.070

## CONTROL PORT

The ADAU1788 has a 4-wire SPI control port and a 2-wire I<sup>2</sup>C bus control port. Each port can set the memories and registers. The IC defaults to I<sup>2</sup>C mode but can be put into SPI control mode by pulling the SS pin low three times. When in I<sup>2</sup>C mode, the unused control pins determine the I<sup>2</sup>C device address. The D3 pin must be connected to DGND for the I<sup>2</sup>C/SPI operation.

The control port is capable of full read/write operation for all addressable memories and registers. Most signal processing parameters are controlled by writing new values to the parameter memories using the control port. Other functions, such as mute and input/output mode control, are programmed through the registers.

All addresses can be accessed in either single address mode or burst mode. The first byte (Byte 0) of a control port write contains the 7-bit IC address plus the R/W bit. The next two bytes (Byte 1 and Byte 2) are the 16-bit subaddress of the memory or register location within the ADAU1788. All subsequent bytes (starting with Byte 3) contain the data, such as the register, program, or parameter data. The exact formats for specific types of writes are shown in Figure 60 and Figure 61.

If large blocks of data must be downloaded to the ADAU1788 DSP cores, the output of the cores can be disabled, new data can be loaded, and the core can then be restarted. This restart is typically done during the booting sequence at start-up or when loading a new program into memory.

**Table 29. Control Pins Function Setup List**

Mode	IOVDD (V)	I <sup>2</sup> C Address	BCLK0 Pin	SDATAO_0 Pin	ADDR1/ MOSI Pin	ADDR0/ SS Pin	SCL/ SCLK Pin	SDA/ MISO Pin	D3 Pin
Input	1.2 to 1.8	0x28	BCLK0	SDATAO_0	0	0	SCL	SDA	0
I <sup>2</sup> C	1.2 to 1.8	0x29	BCLK0	SDATAO_0	0	1	SCL	SDA	0
I <sup>2</sup> C	1.2 to 1.8	0x2A	BCLK0	SDATAO_0	1	0	SCL	SDA	0
I <sup>2</sup> C	1.2 to 1.8	0x2B	BCLK0	SDATAO_0	1	1	SCL	SDA	0
SPI	1.2 to 1.8	Not applicable	BCLK0	SDATAO_0	MOSI	SS	SCLK	MISO	0

**Table 30. I<sup>2</sup>C/SPI Control Data Word Sizes and Address Ranges**

Base Address	End Address	Description	Width per Address	Write Modes	Writes Needed for Update
0x0000	0x0F00	Reserved	Not applicable	Not applicable	Not applicable
0x2000	0x3FFF	SigmaDSP parameter RAM	8	Direct, safeload	4
0x5000	0x77FF	SigmaDSP program RAM	8	Direct	5
0x7800	0x97FF	SigmaDSP data RAM	8	Direct	4
0xC000	0xC0E1	Control registers	8	Direct	1
0xD000	0xD0FF	FastDSP program	8	Direct	4
0xD100	0xDFFF	FastDSP parameter	8	Direct safeload	4
0xE000	0xE3FF	FastDSP state	8	Direct	4

Registers and bits shown as reserved in the register map read back 0s.

The control port pins are multifunctional, depending on the mode in which the device is operating. Table 28 describes these multiple functions.

**Table 28. Control Port Pin Functions**

Pin	I <sup>2</sup> C Mode	SPI Mode
SCL/SCLK	SCL—input	SCLK—input
SDA/MISO	SDA—open-collector output	MISO—output
ADDR1/MOSI	I <sup>2</sup> C Address Bit 1—input	MOSI—input
ADDR0/SS	I <sup>2</sup> C Address Bit 0—input	SS—input

## BURST MODE COMMUNICATION

Burst mode addressing, in which the subaddresses are automatically incremented at word boundaries, can be used for writing large amounts of data to contiguous memory locations. This increment happens automatically after a single-word write unless the control port communication is stopped (that is, a stop condition is issued for I<sup>2</sup>C, or SS is brought high for SPI).

The registers and RAMs in the ADAU1788 range in width from one byte to five bytes, so the auto-increment feature knows the mapping between subaddresses and the word length of the destination register (or memory location).

## READING AND WRITING TO MEMORIES

All SigmaDSP and FastDSP memory locations are larger than a single byte. While each byte occupies a single address when communicating over a control interface (I<sup>2</sup>C or SPI), when writing to these memories, an entire memory word must be written starting with the lowest address and continuing sequentially to the highest address for a write to actually occur. Similarly, a read must begin at the lowest memory address. However, for reads, all locations must not be read. The mapping of bytes over the control interface is the most significant byte, or a memory location is written or read first, and the least significant byte is written or read last. The memories can be read or written in burst mode or single byte mode so that the proceeding requirements are met.

**Table 31. Example Write to SigmaDSP Program RAM Word 0**

Address	Data
0x5000	Data, Bits[39:32]
0x5001	Data, Bits[31:24]
0x5002	Data, Bits[23:16]
0x5003	Data, Bits[15:8]
0x5004	Data, Bits[7:0], the memory is written to after this write

## I<sup>2</sup>C PORT

The ADAU1788 supports a 2-wire serial (I<sup>2</sup>C-compatible) microprocessor bus driving multiple peripherals. I<sup>2</sup>C uses two pins, serial data (SDA) and serial clock (SCL), to carry data between the ADAU1788 and the system I<sup>2</sup>C master controller. In I<sup>2</sup>C mode, the ADAU1788 is always a slave on the bus.

The device supports fast mode plus I<sup>2</sup>C operation, but for most bus capacitances, the SDA\_MISO\_DRIVE bit must be set to 1 to support these operating speeds.

Each slave device is recognized by a unique 7-bit device address. The ADAU1788 I<sup>2</sup>C address format is shown in Table 32. The LSB of this first byte sent from the I<sup>2</sup>C master sets either a read or write operation. Logic Level 1 corresponds to a read operation, and Logic Level 0 corresponds to a write operation.

Pin ADDR0 and Pin ADDR1 set the LSBs of the I<sup>2</sup>C address (see Table 33). Therefore, each ADAU1788 can be set to one of four unique addresses, allowing multiple ICs to exist on the same I<sup>2</sup>C bus without address contention. The 7-bit I<sup>2</sup>C addresses are shown in Table 33.

An I<sup>2</sup>C data transfer is always terminated by a stop condition.

Both SDA and SCL must have 2.0 k $\Omega$  pull-up resistors on the lines connected to these pins. The voltage on these signal lines cannot be higher than IOVDD.

**Table 32. I<sup>2</sup>C Address Format**

Bit 6	Bit 5	Bit 4	Bit 3	Bit 2	Bit 1	Bit 0
0	1	0	1	0	ADDR1	ADDR0

**Table 33. I<sup>2</sup>C Addresses**

ADDR1 (MOSI)	ADDR0 (SS)	Slave Address
0	0	0x28
0	1	0x29
1	0	0x2A
1	1	0x2B

## Addressing

Initially, each device on the I<sup>2</sup>C bus is in an idle state and monitoring the SDA and SCL lines for a start condition and the proper address. The I<sup>2</sup>C master initiates a data transfer by establishing a start condition, defined by a high to low transition on SDA while SCL remains high, indicating that an address/ data stream follows. All devices on the bus respond to the start condition and shift the next eight bits (the 7-bit address plus the R/W bit) MSB first. The device that recognizes the transmitted address responds by pulling the data line low during the ninth clock pulse. This ninth bit is known as an acknowledge bit. All other devices withdraw from the bus at this point and return to the idle condition. The R/W bit determines the direction of the data. A Logic 0 on the LSB of the first byte indicates that the master writes information to the peripheral, whereas a Logic 1 indicates that the master reads information from the peripheral after writing the subaddress and repeating the start address. A data transfer takes place until a stop condition is encountered. A stop condition occurs when SDA transitions from low to high while SCL is held high. Figure 58 shows the timing of an I<sup>2</sup>C write, and Figure 59 shows an I<sup>2</sup>C read.

Stop and start conditions can be detected at any stage during the data transfer. If these conditions are asserted out of sequence with normal read and write operations, the ADAU1788 immediately jumps to the idle condition. During a given SCL high period, the user can only issue one start condition, one stop condition, or a single stop condition followed by a single start condition. A no-acknowledge condition is where the SDA line is not pulled low on the ninth clock pulse on SCL. If an invalid subaddress is issued by the user, the ADAU1788 issues an acknowledge, but no data write occurs, and a read returns zeros. If the highest subaddress location is reached while in write mode, the data for the invalid byte is not loaded to any subaddress register.

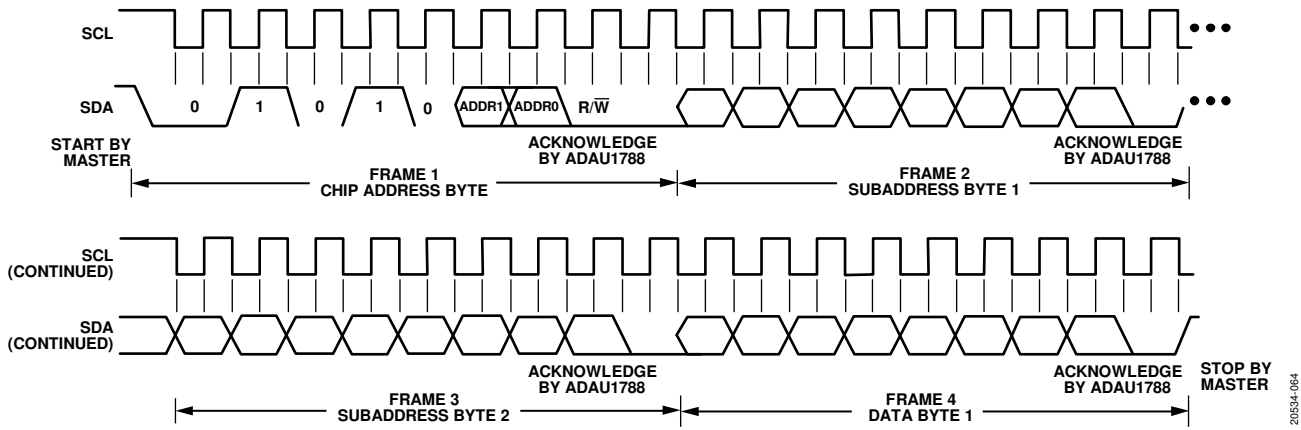

Figure 58. I<sup>2</sup>C Write to ADAU1788 Clcking

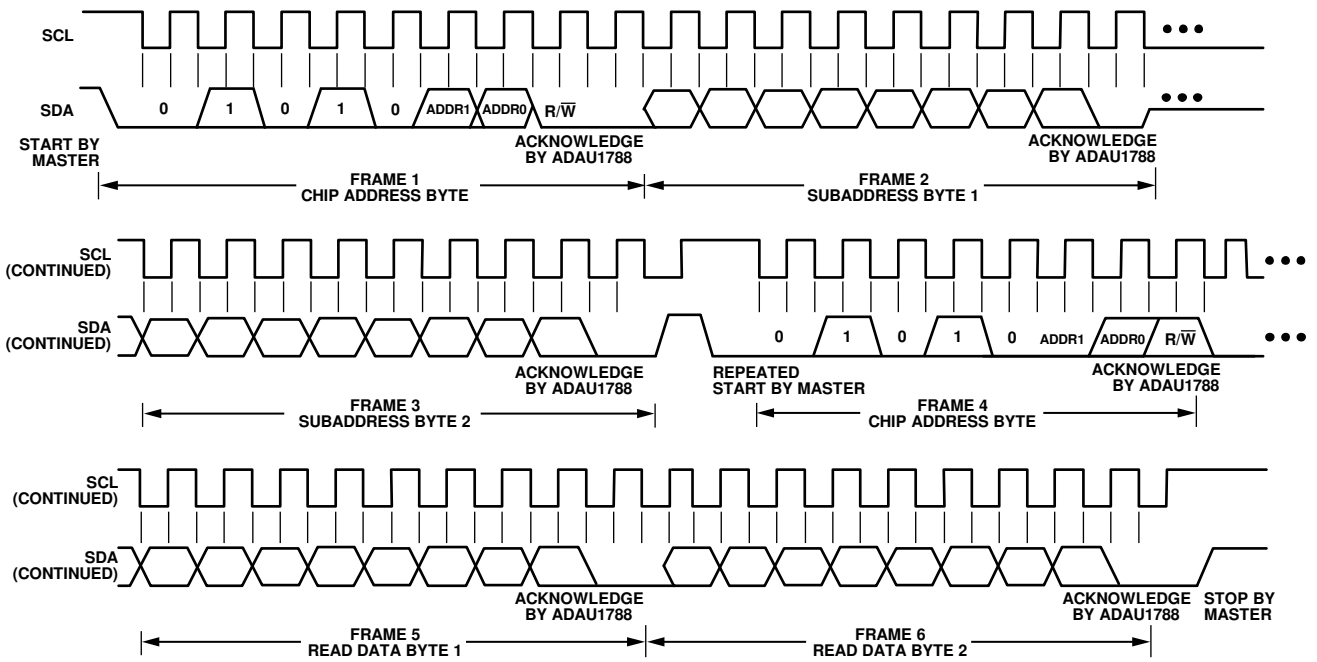

Figure 59. I<sup>2</sup>C Read from ADAU1788 Clcking

**I<sup>2</sup>C Read and Write Operations**

Figure 60 shows the timing of a single-word write operation. Every ninth clock pulse, the ADAU1788 issues an acknowledge by pulling SDA low.

Figure 61 shows the timing of a burst mode write sequence. Figure 61 shows an example where the target destination words are two bytes, such as the program memory. The ADAU1788 knows to increment its subaddress register every two bytes because the requested subaddress corresponds to a register or memory area with a 2-byte word length.

The timing of a single-word read operation is shown in Figure 62. Note that the first R/W bit is 0, indicating a write operation because the subaddress still must be written to set up the internal address. After the ADAU1788 acknowledges the receipt of the subaddress, the master must issue a repeated start command, followed by the chip address byte with the R/W set to 1 (read), causing the ADAU1788 SDA to reverse and begin driving data

back to the master. The master then responds every ninth pulse with an acknowledge pulse to the ADAU1788.

Figure 63 shows the timing of a burst mode read sequence. Figure 63 shows an example where the target read words are two bytes. The ADAU1788 increments its subaddress every two bytes because the requested subaddress corresponds to a register or memory area with word lengths of two bytes. Other address ranges may have a variety of word lengths, ranging from one byte to four bytes. The ADAU1788 always decodes the subaddress and sets the auto-increment circuit so that the address increments after the appropriate number of bytes.

Figure 60 to Figure 63 use the following abbreviations:

- S is the start bit.
- P is the stop bit.
- AM is acknowledge by master.
- AS is acknowledge by slave.

S	I <sup>2</sup> C ADDRESS, R/W = 0	AS	SUBADDRESS HIGH	AS	SUBADDRESS LOW	AS	DATA BYTE 1	AS	DATA BYTE 2	...	AS	DATA BYTE N	P
---	-----------------------------------	----	-----------------	----	----------------	----	-------------	----	-------------	-----	----	-------------	---

20534-066

Figure 60. Single-Word I<sup>2</sup>C Write Format

S	I <sup>2</sup> C ADDRESS, R/W = 0	AS	SUBADDRESS HIGH	AS	SUBADDRESS LOW	AS	DATA-WORD 1, BYTE 1	AS	DATA-WORD 1, BYTE 2	AS	DATA-WORD 2, BYTE 1	AS	DATA-WORD 2, BYTE 2	AS	...	P
---	-----------------------------------	----	-----------------	----	----------------	----	---------------------	----	---------------------	----	---------------------	----	---------------------	----	-----	---

20534-067

Figure 61. Burst Mode I<sup>2</sup>C Write Format

S	I <sup>2</sup> C ADDRESS, R/W = 0	AS	SUBADDRESS HIGH	AS	SUBADDRESS LOW	AS	S	I <sup>2</sup> C ADDRESS, R/W = 1	AS	DATA BYTE 1	AM	DATA BYTE 2	...	AM	DATA BYTE N	P
---	-----------------------------------	----	-----------------	----	----------------	----	---	-----------------------------------	----	-------------	----	-------------	-----	----	-------------	---

20534-068

Figure 62. Single-Word I<sup>2</sup>C Read Format

S	I <sup>2</sup> C ADDRESS, R/W = 0	AS	SUBADDRESS HIGH	AS	SUBADDRESS LOW	AS	S	I <sup>2</sup> C ADDRESS, R/W = 1	AS	DATA-WORD 1, BYTE 1	AM	DATA-WORD 1, BYTE 2	AM	...	P
---	-----------------------------------	----	-----------------	----	----------------	----	---	-----------------------------------	----	---------------------	----	---------------------	----	-----	---

20534-069

Figure 63. Burst Mode I<sup>2</sup>C Read Format

**SPI PORT**

By default, the ADAU1788 is in I<sup>2</sup>C mode, but the device can be put in SPI control mode by pulling  $\overline{SS}$  low three times by issuing three SPI writes, which are in turn ignored by the ADAU1788. The next (fourth) SPI write is then latched in the SPI port.

The SPI port uses a 4-wire interface, consisting of  $\overline{SS}$ , SCLK, MOSI, and MISO signals, and is always a slave port. The  $\overline{SS}$  signal must go low at the beginning of a transaction and high at the end of a transaction. The SCLK signal latches MOSI on a low to high transition. MISO data is shifted out of the ADAU1788 on the falling edge of SCLK and must be clocked to a receiving device, such as a microcontroller, on the SCLK rising edge. The MOSI signal carries the serial input data, and the MISO signal is the serial output data. The MISO signal remains tristated until a read operation is requested, allowing other SPI-compatible peripherals to share the same readback line.

All SPI transactions have the same basic format shown in Table 34. The timing diagrams for SPI write and SPI read are shown in Figure 64 and Figure 65, respectively. All data must be written MSB first. The ADAU1788 can only be taken out of SPI mode by pulling the PD pin low or by powering down the IC.

**Table 34. Generic SPI Word Format**

Byte 0	Byte 1	Byte 2	Byte 3	Byte 4	Byte 5 <sup>1</sup>
0000000, R/W	Register/memory address, Bits[15:8]	Register/memory address, Bits[7:0]	Zeros, Bits[7:0] (dummy)	Data	Data

<sup>1</sup> Continues to end of data.

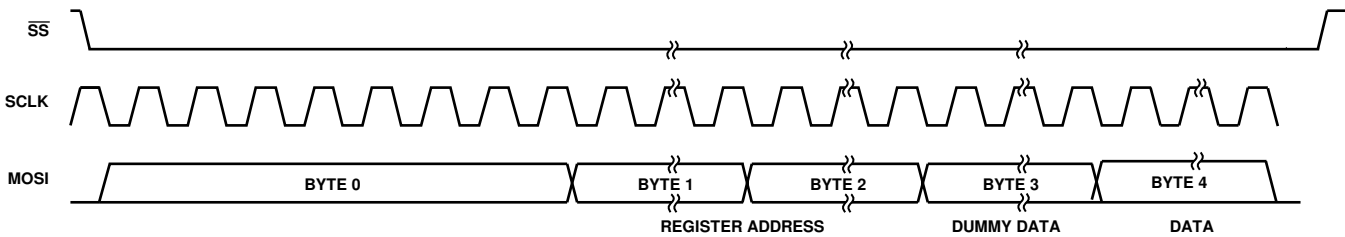

Figure 64. SPI Write to ADAU1788 Clocking (Single-Write Mode)

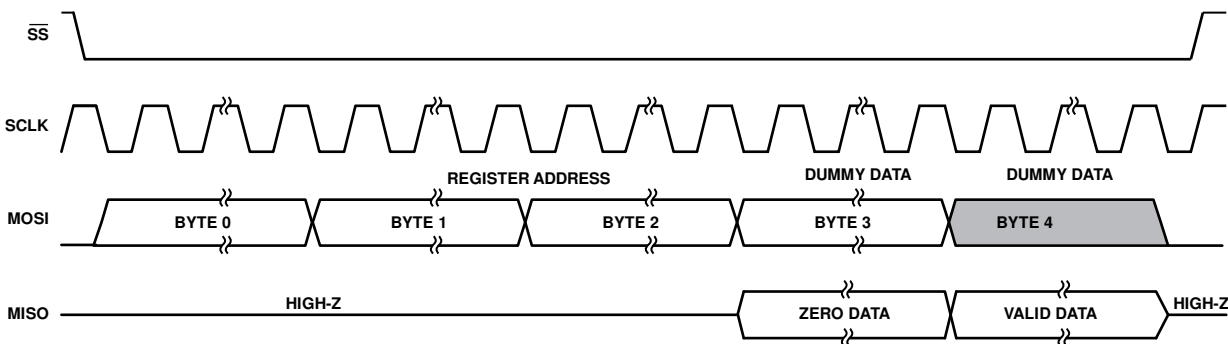

Figure 65. SPI Read from ADAU1788 Clocking (Single-Read Mode)

**R/W**

The first byte of an SPI transaction indicates whether the communication is a read or a write with the R/W bit. The LSB of this first byte determines whether the SPI transaction is a read (Logic Level 1) or a write (Logic Level 0).

**Subaddress**

The 16-bit subaddress word is decoded into a location in one of the memories or registers. This subaddress is the location of the appropriate memory location or register.

It is necessary to add an unused byte of zeros after the subaddress to effectively make the subaddress 24 bits with the actual address placed in the 16 MSBs.

**Data Bytes**

The number of data bytes varies according to the register or memory being accessed. During a burst mode write, an initial subaddress is written followed by a continuous sequence of data for consecutive memory and/or register locations.

A sample timing diagram for a single-write SPI operation to the parameter RAM is shown in Figure 64. A sample timing diagram of a single-read SPI operation is shown in Figure 65. The MISO pin goes from tristate to being driven at the beginning of Byte 3. In this example, Byte 0 to Byte 2 contain the addresses and the R/W bit and subsequent bytes carry the data.

## MULTIPURPOSE PINS

The ADAU1788 has eleven multipurpose (MPx) pins that can be used for serial data I/O, digital microphone inputs, clock outputs, PDM outputs, and interrupts. Each pin can be individually set to either its default or MPx setting. The function of each of these pins is set in using the MPx\_MODE bits. By default, each pin is configured as its normal function.

When an MPx pin is set as a general-purpose input, the MPx pin can be read via all control interfaces via the GPIOx\_IN bits, the pin can also be read and acted upon by the SigmaDSP core, and the pin can be used to conditionally execute instructions or trigger the compressor in the FastDSP. When an MPx pin is set as general-purpose output, the state of the pin can be set via all control interfaces using the GPIOx\_OUT bits or by the SigmaDSP core. The GPIO maps to the corresponding MPx pin, for example, GPIO1 maps to BCLK\_0/MP1.

Any MPx pin can be used as a master clock output. The rate of the master clock output is determined by the MCLKO\_RATE bits. Multiple pins can be used as this function if desired.

Any MPx pin can be used to output the PDM clock or data signal for the PDM output interface.

Any MPx pin can be used to output the interrupt status from the two interrupt sources.

**Table 35. Multipurpose Pin Functions**

MPx Pin Function <sup>1</sup>	Direction
General-Purpose Input (GPI)	In
General-Purpose Output from GPIOx_OUT Bits (GPO_REG)	Out
General-Purpose Output from SigmaDSP (GPO_SDSP)	Out
MCLK Output (MCLKO)	Out
IRQ1 Output (IRQ1)	Out
IRQ2 Output (IRQ2)	Out

<sup>1</sup> These functions are enumeration options in Register 0xC08B through Register 0xC090 that any of the MPx pins can be set to.

## Interrupts

Each multipurpose pin can be used to output one of two interrupts that have various sources when selected for this function. The sources for the interrupts are for DAC and ADC channels clipping, PLL locking or unlocking, input and output ASRCs locking or unlocking, the generic SigmaDSP interrupts, and the AVDD undervoltage warning. Each interrupt source can be individually masked with their respective IRQx\_MASKx registers. Each interrupt output can be set to active low or active high output on the pin selected for the interrupt output via the IRQx\_FUNC bits.

The status of each interrupt source can be read via the IRQ status registers (IRQx\_STATUSx). When an interrupt source is masked, if that interrupt becomes true, the interrupt is shown in the interrupt status registers but does not cause the MPx pin (if set as IRQx) to show an interrupt. All sources of each interrupt are cleared via a write of 1 to the IRQx\_CLEAR bits. The interrupt status bits are sticky, such that if an interrupt source becomes true, the status reads 1 until a clear occurs, even if that interrupt source is no longer true.

The SigmaDSP interrupts are initiated by the SigmaDSP writing to the SDSP\_INTx bits.

## Pin Controls

Each pin that can be used as a multipurpose pin has several control selections to set various setting. When the pin is used as an output, the drive strength can be selected at 2 mA, 4 mA, 8 mA, or 12 mA. In addition, a weak pull-up or pull-down can be selected. These settings are in their respective pin control register. These pin control settings affect the pins operation in both normal functional mode and when used in all multipurpose pin modes.

## SERIAL DATA PORT

The serial data input and output port of the ADAU1788 can be set to accept or transmit data in a 2-channel format such as I<sup>2</sup>S or up to 16 channels in a time division multiplexing (TDM) stream to interface to external ADCs, DAC, DSPs, and system on chips (SOCs). Data is processed in twos complement, MSB first format. The left channel data field always precedes the right channel data field in 2-channel streams.

The serial data clocks do not need to be synchronous with the ADAU1788 master clock input, but the frame clock and bit clock must be synchronous to each other. The FSYNC\_0 and BCLK\_0 pins are used to clock both the serial input and output ports. The pins can also be used as a source to the PLL to provide the main chip clock. The serial port can be set to be either the master or the slave in a system. Because there is only one set of serial data clocks, the input and output of the port must always both be either master or slave.

The SPT0\_SAI\_MODE bits set whether the serial port is operating in stereo mode or TDM mode. In stereo modes, both edges of frame clock determine where data is placed, and the left channel maps to the output for Channel 0, while the right channel maps to the output for Channel 1. In TDM mode only, the rising edge of frame clock determine where data is placed. In TDM mode, each channel of data receives a slot that can be either 16, 24, or 32 BCLKs wide. The width of each slot is determined by the SPT0\_SLOT\_WIDTH bits.

The serial data control registers allow control of the clock polarity and the data input modes. The valid data formats are I<sup>2</sup>S (delay by 1), left justified (delay by 0), or right justified (delay by 8, 12, or 16 BCLKs). The delay indicates the number of bit clocks BCLKs from the rising/falling edge of frame clock FSYNC\_0 where the MSB of the data is placed in stereo modes, and the number of bit clocks BCLKs from the rising of frame clock in TDM mode. In all modes except for the right justified mode, the serial port inputs an arbitrary number of bits up to a limit of 24. Extra bits do not cause an error, but the bits are ignored. The serial port can operate with an arbitrary number of bit clock BCLK\_0 transitions in each frame clock frame.

**Table 36. Serial Port Data Format Settings**

<b>Format</b>	<b>Frame Clock Mode, Bit (SPT0_SAI_MODE)</b>	<b>Sets the Slot Width per Channel, Bit (SPT0_SLOT_WIDTH)<sup>1</sup></b>	<b>Sets the MSB Position from Start of Frame Clock, Bit (SPT0_DATA_FORMAT)</b>
I <sup>2</sup> S (See Figure 66)	0 (50 % duty cycle)	XX	000 (One bit clock delay)
Left Justified (See Figure 66)	0	XX	001 (No delay)
Right Justified (See Figure 66)	0	XX	010 (delay by 8 bit clocks)
	0	XX	011 (delay by 12 bit clocks)
	0	XX	100 (delay by 16 bit clocks)
TDM (See Figure 67)	1 (single bit clock wide pulse)	XX	000

<sup>1</sup> X = don't care.

When using a high bit clock rate (12.288 MHz or higher), it is recommended to increase the drive strength settings for the output signal pins. The high drive strength effectively speeds up the transition times of the waveforms, thereby improving the signal integrity of the clock and data lines. The drive strength can be set in the pad drive strength registers (Register 0xC094 through Register 0xC0A0).

Table 36 describes the proper serial port settings for standard audio data formats. More information about the settings in Table 36 can be found in the SPT0\_CTRLx register descriptions.

The polarity of both frame clock and bit clock can be inverted via the SPT0\_LRCLK\_POL and SPT0\_BCLK\_POL bits. These bits do not need to be used to support the typical formats shown in Table 36. Setting either SPT0\_LRCLK\_POL or SPT0\_BCLK\_POL to 1 places an inverter at the input to the serial port on its respective signal. For example, while serial data and frame clock are normally sampled on the rising edge of bit clock, setting SPT0\_BCLK\_POL = 1 samples on the falling edge of bit clock.

Each serial port can be set to be a master, in which case BCLK\_0 and FSYNC\_0 are driven as outputs. The output rate and direction of these two signals are set via the SPT0\_LRCLK\_SRC and SPT0\_BCLK\_SRC bits. A bit clock rate higher than 24.576 MHz cannot be generated. Therefore, the settings of these registers that request this rate result in no bit clock.

Unused bit slots can be tristated so that multiple ICs can drive a single serial data bus, which is controlled via the SPT0\_TRI\_STATE bit. For example, in a 32-bit TDM frame with 24-bit data, the eight unused bits are tristated. Inactive channels are also tristated for one full frame each. Serial output channels are disabled when the SPT0\_OUT\_ROUTEy bits are set to 0x3E. Note that the timing for serial data output changes based on the minimum IOVDD voltage. While the serial port can work for inputting a signal on SDATAI\_0 for any IOVDD and bit clock rate within the specification, the delay on SDATAO\_0 at 1.1 V excludes operating at higher bit clock rates.



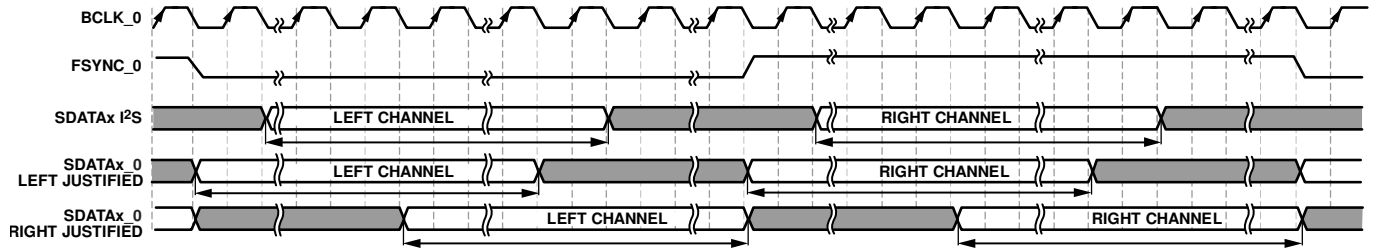

20534-073

Figure 66. Stereo Modes: I2S, Left Justified, and Right Justified Modes, 16 Bits to 24 Bits per Channel, Any Number of BCLKs Are Allowed

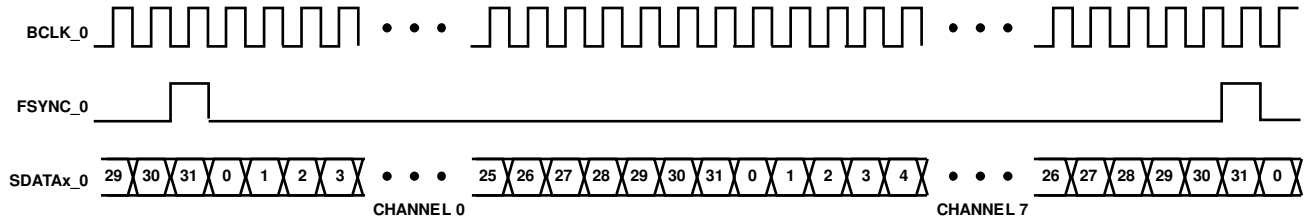

20534-074

Figure 67. 8-Channel TDM Mode, Default Settings, Except SPT0\_SAI\_MODE = 1

## APPLICATIONS INFORMATION

### POWER SUPPLY BYPASS CAPACITORS

Bypass each analog and digital power supply pin to its nearest appropriate ground pin with a single 0.1  $\mu$ F capacitor. The connections to each side of the capacitor must be as short as possible, and the trace must be routed on a single layer with no vias. For maximum effectiveness, locate the capacitor equidistant from the power and ground pins or slightly closer to the power pin if equidistant placement is not possible. Thermal connections to the ground planes must be made on the far side of the capacitor.

Each supply signal on the board must also be bypassed with a single bulk capacitor (10  $\mu$ F to 47  $\mu$ F).

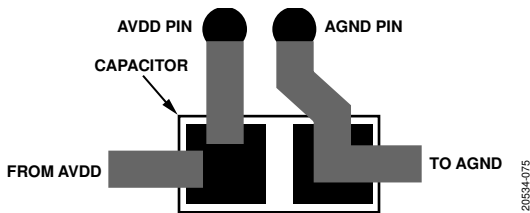

Figure 68. Recommended Power Supply Bypass Capacitor Layout

### LAYOUT

The HPVDD supply is for the headphone amplifiers. If the headphone amplifiers are enabled, the PCB trace to this pin must be wider than the traces to other pins to increase the current carrying capacity. A wider trace must also be used for the headphone output lines.

### GROUNDING

Use a single ground plane in the application layout. Place the components in the analog signal path away from the digital signals.

### PCB STACKUP

Figure 69 shows the PCB stackup.

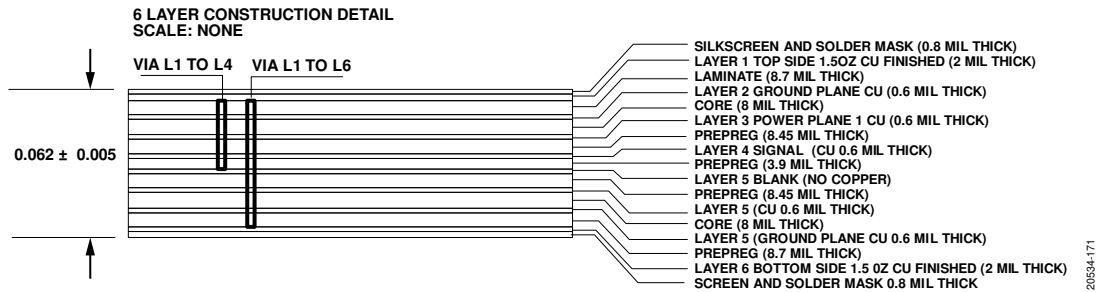

Figure 69. PCB Stackup

## REGISTER SUMMARY

Table 37. Register Summary

Reg. (Hex.)	Name	Bits	Bit 7	Bit 6	Bit 5	Bit 4	Bit 3	Bit 2	Bit 1	Bit 0	Reset	R/W	
C000	VENDOR_ID	[7:0]	VENDOR								0x41	R	
C001	DEVICE_ID1	[7:0]	DEVICE1								0x17	R	
C002	DEVICE_ID2	[7:0]	DEVICE2								0x87	R	
C003	REVISION	[7:0]	REV								0x01	R	
C004	ADC_DAC_HP_PWR	[7:0]	RESERVED			PB0_EN	RESERVED		ADC1_EN	ADC0_EN	0x00	R/W	
C005	PLL_MB_PGA_PWR	[7:0]	RESERVED		PGA1_EN	PGA0_EN	MBIAS1_EN	MBIAS0_EN	XTAL_EN	PLL_EN	0x02	R/W	
C006	DMIC_PWR	[7:0]	RESERVED				DMIC3_EN	DMIC2_EN	DMIC1_EN	DMIC0_EN	0x00	R/W	
C007	SAL_CLK_PWR	[7:0]	PDM1_EN	PDM0_EN	DMIC_CLK1_EN	DMIC_CLK0_EN	RESERVED		SPT0_OUT_EN	SPT0_IN_EN	0x00	R/W	
C008	DSP_PWR	[7:0]	RESERVED			SDSP_EN	RESERVED			FDSP_EN	0x00	R/W	
C009	ASRC_PWR	[7:0]	ASRCO3_EN	ASRCO2_EN	ASRCO1_EN	ASRCO0_EN	ASRCI3_EN	ASRCI2_EN	ASRCI1_EN	ASRCI0_EN	0x00	R/W	
C00A	FINT_PWR	[7:0]	FINT7_EN	FINT6_EN	FINT5_EN	FINT4_EN	FINT3_EN	FINT2_EN	FINT1_EN	FINT0_EN	0x00	R/W	
C00B	FDEC_PWR	[7:0]	FDEC7_EN	FDEC6_EN	FDEC5_EN	FDEC4_EN	FDEC3_EN	FDEC2_EN	FDEC1_EN	FDEC0_EN	0x00	R/W	
C00C	KEEPS	[7:0]	RESERVED			CM_KEEP_ALIVE	RESERVED		KEEP_SDSP	KEEP_FDSP	0x10	R/W	
C00D	CHIP_PWR	[7:0]	RESERVED		DLDO_CTRL		RESERVED	CM_STARTUP_OVER	MASTER_BLOCK_EN	POWER_EN	0x10	R/W	
C00E	CLK_CTRL1	[7:0]	SYNC_SOURCE		PLL_BYPASS	PLL_TYPE	XTAL_MODE	PLL_SOURCE			0xC8	R/W	
C00F	CLK_CTRL2	[7:0]	RESERVED				PLL_INPUT_PRESCALER				0x00	R/W	
C010	CLK_CTRL3	[7:0]	RESERVED			PLL_INTEGER_DIVIDER[12:8]					0x00	R/W	
C011	CLK_CTRL4	[7:0]	PLL_INTEGER_DIVIDER[7:0]								0x02	R/W	
C012	CLK_CTRL5	[7:0]	PLL_NUMERATOR[15:8]								0x00	R/W	
C013	CLK_CTRL6	[7:0]	PLL_NUMERATOR[7:0]								0x00	R/W	
C014	CLK_CTRL7	[7:0]	PLL_DENOMINATOR[15:8]								0x00	R/W	
C015	CLK_CTRL8	[7:0]	PLL_DENOMINATOR[7:0]								0x00	R/W	
C016	CLK_CTRL9	[7:0]	RESERVED								PLL_UPDATE	0x00	R/W
C017	ADC_CTRL1	[7:0]	RESERVED				ADC01_DEC_ORDER	ADC01_FS				0x22	R/W
C018	ADC_CTRL2	[7:0]	RESERVED					ADC01_IBIAS				0x00	R/W
C019	ADC_CTRL3	[7:0]	RESERVED						ADC1_HPF_EN	ADC0_HPF_EN	0x00	R/W	
C01A	ADC_CTRL4	[7:0]	RESERVED	ADC_VOL_ZC	ADC_VOL_LINK	ADC_HARD_VOL	RESERVED			ADC01_FCOMP	0x40	R/W	
C01B	ADC_CTRL5	[7:0]	RESERVED			DIFF_INPUT	ADC_AIN_CHRG_TIME				0x26	R/W	
C01C	ADC_MUTES	[7:0]	RESERVED						ADC1_MUTE	ADC0_MUTE	0x00	R/W	
C01D	ADC0_VOL	[7:0]	ADC0_VOL								0x40	R/W	
C01E	ADC1_VOL	[7:0]	ADC1_VOL								0x40	R/W	

Reg. (Hex.)	Name	Bits	Bit 7	Bit 6	Bit 5	Bit 4	Bit 3	Bit 2	Bit 1	Bit 0	Reset	R/W			
C021	PGA0_CTRL1	[7:0]	PGA0_SLEW_DIS	PGA0_BOOST	PGA0_GAIN[10:5]							0x00	R/W		
C022	PGA0_CTRL2	[7:0]	RESERVED			PGA0_GAIN[4:0]							0x00	R/W	
C023	PGA1_CTRL1	[7:0]	PGA1_SLEW_DIS	PGA1_BOOST	PGA1_GAIN[10:5]							0x00	R/W		
C024	PGA1_CTRL2	[7:0]	RESERVED			PGA1_GAIN[4:0]							0x00	R/W	
C029	PGA_CTRL	[7:0]	RESERVED			PGA_GAIN_LINK	RESERVED		PGA_SLEW_RATE				0x00	R/W	
C02A	MBIAS_CTRL	[7:0]	RESERVED		MBIAS_IBIAS		RESERVED		MBIAS1_LEVEL	MBIAS0_LEVEL			0x00	R/W	
C02B	DMIC_CTRL1	[7:0]	RESERVED	DMIC_CLK1_RATE			RESERVED	DMIC_CLK0_RATE					0x33	R/W	
C02C	DMIC_CTRL2	[7:0]	DMIC01_MAP	DMIC01_EDGE	DMIC01_FCOMP	DMIC01_DEC_ORDER	DMIC01_HPF_EN	DMIC01_FS					0x01	R/W	
C02D	DMIC_CTRL3	[7:0]	DMIC23_MAP	DMIC23_EDGE	DMIC23_FCOMP	DMIC23_DEC_ORDER	DMIC23_HPF_EN	DMIC23_FS					0x01	R/W	
C030	DMIC_CTRL6	[7:0]	RESERVED				DMIC_VOL_ZC	DMIC_VOL_LINK	DMIC_HARD_VOL				0x04	R/W	
C031	DMIC_MUTES	[7:0]	RESERVED				DMIC3_MUTE	DMIC2_MUTE	DMIC1_MUTE	DMIC0_MUTE			0x00	R/W	
C032	DMIC_VOL0	[7:0]	DMIC0_VOL											0x40	R/W
C033	DMIC_VOL1	[7:0]	DMIC1_VOL											0x40	R/W
C034	DMIC_VOL2	[7:0]	DMIC2_VOL											0x40	R/W
C035	DMIC_VOL3	[7:0]	DMIC3_VOL											0x40	R/W
C03A	DAC_CTRL1	[7:0]	DAC_MORE_FILTER	DAC_LPM	DAC_IBIAS		DAC_FCOMP	DAC_FS					0x02	R/W	
C03B	DAC_CTRL2	[7:0]	RESERVED	DAC0_MUTE	RESERVED	DAC0_HPF_EN	DAC_LPM_II	DAC_VOL_ZC	DAC_HARD_VOL	RESERVED			0xC4	R/W	
C03C	DAC_VOL0	[7:0]	DAC0_VOL											0x40	R/W
C03E	DAC_ROUTE0	[7:0]	RESERVED	DAC0_ROUTE										0x00	R/W
C040	HP_CTRL	[7:0]	RESERVED								HP0_MODE			0x00	R/W
C041	FDEC_CTRL1	[7:0]	RESERVED	FDEC01_OUT_FS			RESERVED	FDEC01_IN_FS					0x25	R/W	
C042	FDEC_CTRL2	[7:0]	RESERVED	FDEC23_OUT_FS			RESERVED	FDEC23_IN_FS					0x25	R/W	
C043	FDEC_CTRL3	[7:0]	RESERVED	FDEC45_OUT_FS			RESERVED	FDEC45_IN_FS					0x25	R/W	
C044	FDEC_CTRL4	[7:0]	RESERVED	FDEC67_OUT_FS			RESERVED	FDEC67_IN_FS					0x25	R/W	
C045	FDEC_ROUTE0	[7:0]	RESERVED			FDEC0_ROUTE							0x00	R/W	
C046	FDEC_ROUTE1	[7:0]	RESERVED			FDEC1_ROUTE							0x00	R/W	
C047	FDEC_ROUTE2	[7:0]	RESERVED			FDEC2_ROUTE							0x00	R/W	
C048	FDEC_ROUTE3	[7:0]	RESERVED			FDEC3_ROUTE							0x00	R/W	
C049	FDEC_ROUTE4	[7:0]	RESERVED			FDEC4_ROUTE							0x00	R/W	
C04A	FDEC_ROUTE5	[7:0]	RESERVED			FDEC5_ROUTE							0x00	R/W	
0xC04B	FDEC_ROUTE6	[7:0]	RESERVED			FDEC6_ROUTE							0x00	R/W	
C04C	FDEC_ROUTE7	[7:0]	RESERVED			FDEC7_ROUTE							0x00	R/W	

Reg. (Hex.)	Name	Bits	Bit 7	Bit 6	Bit 5	Bit 4	Bit 3	Bit 2	Bit 1	Bit 0	Reset	R/W		
C04D	FINT_CTRL1	[7:0]	RESERVED	FINT01_OUT_FS			RESERVED	FINT01_IN_FS			0x52	R/W		
C04E	FINT_CTRL2	[7:0]	RESERVED	FINT23_OUT_FS			RESERVED	FINT23_IN_FS			0x52	R/W		
C04F	FINT_CTRL3	[7:0]	RESERVED	FINT45_OUT_FS			RESERVED	FINT45_IN_FS			0x52	R/W		
C050	FINT_CTRL4	[7:0]	RESERVED	FINT67_OUT_FS			RESERVED	FINT67_IN_FS			0x52	R/W		
C051	FINT_ROUTE0	[7:0]	RESERVED	FINT0_ROUTE								0x00	R/W	
C052	FINT_ROUTE1	[7:0]	RESERVED	FINT1_ROUTE								0x00	R/W	
C053	FINT_ROUTE2	[7:0]	RESERVED	FINT2_ROUTE								0x00	R/W	
C054	FINT_ROUTE3	[7:0]	RESERVED	FINT3_ROUTE								0x00	R/W	
C055	FINT_ROUTE4	[7:0]	RESERVED	FINT4_ROUTE								0x00	R/W	
C056	FINT_ROUTE5	[7:0]	RESERVED	FINT5_ROUTE								0x00	R/W	
C057	FINT_ROUTE6	[7:0]	RESERVED	FINT6_ROUTE								0x00	R/W	
C058	FINT_ROUTE7	[7:0]	RESERVED	FINT7_ROUTE								0x00	R/W	
C059	ASRCI_CTRL	[7:0]	ASRCI_MORE_FILT	ASRCI_VFILT	ASRCI_LPM	RESERVED	ASRCI_LPM_II	ASRCI_OUT_FS			0x02	R/W		
C05A	ASRCI_ROUTE01	[7:0]	ASRCI1_ROUTE				ASRCI0_ROUTE					0x00	R/W	
C05B	ASRCI_ROUTE23	[7:0]	ASRCI3_ROUTE				ASRCI2_ROUTE					0x00	R/W	
C05C	ASRCO_CTRL	[7:0]	ASRCO_MORE_FILT	ASRCO_VFILT	ASRCO_LPM	RESERVED	ASRCO_LPM_II	ASRCO_IN_FS			0x02	R/W		
C05D	ASRCO_ROUTE0	[7:0]	RESERVED		ASRCO0_ROUTE							0x00	R/W	
C05E	ASRCO_ROUTE1	[7:0]	RESERVED		ASRCO1_ROUTE							0x00	R/W	
C05F	ASRCO_ROUTE2	[7:0]	RESERVED		ASRCO2_ROUTE							0x00	R/W	
C060	ASRCO_ROUTE3	[7:0]	RESERVED		ASRCO3_ROUTE							0x00	R/W	
C061	FDSP_RUN	[7:0]	RESERVED								FDSP_RUN	0x00	R/W	
C062	FDSP_CTRL1	[7:0]	FDSP_RAMP_RATE				FDSP_ZERO_STATE	FDSP_RAMP_MODE	FDSP_BANK_SEL			0x70	R/W	
C063	FDSP_CTRL2	[7:0]	RESERVED		FDSP_LAMBDA							0x3F	R/W	
C064	FDSP_CTRL3	[7:0]	RESERVED		FDSP_COPY_CB	FDSP_COPY_CA	FDSP_COPY_BC	FDSP_COPY_BA	FDSP_COPY_AC	FDSP_COPY_AB	0x00	W		
C065	FDSP_CTRL4	[7:0]	RESERVED			FDSP_EXP_ATK_SPEED	FDSP_RATE_SOURCE					0x00	R/W	
C066	FDSP_CTRL5	[7:0]	FDSP_RATE_DIV[15:8]										0x00	R/W
C067	FDSP_CTRL6	[7:0]	FDSP_RATE_DIV[7:0]										0x7F	R/W
C068	FDSP_CTRL7	[7:0]	RESERVED		FDSP_MOD_N							0x00	R/W	
C069	FDSP_CTRL8	[7:0]	FDSP_REG_COND7	FDSP_REG_COND6	FDSP_REG_COND5	FDSP_REG_COND4	FDSP_REG_COND3	FDSP_REG_COND2	FDSP_REG_COND1	FDSP_REG_COND0	0x00	R/W		
C06A	FDSP_SL_ADDR	[7:0]	RESERVED		FDSP_SL_ADDR							0x00	R/W	
C06B	FDSP_SL_P0_3	[7:0]	FDSP_SL_P0[31:24]										0x00	R/W
C06C	FDSP_SL_P0_2	[7:0]	FDSP_SL_P0[23:16]										0x00	R/W
C06D	FDSP_SL_P0_1	[7:0]	FDSP_SL_P0[15:8]										0x00	R/W

Reg. (Hex.)	Name	Bits	Bit 7	Bit 6	Bit 5	Bit 4	Bit 3	Bit 2	Bit 1	Bit 0	Reset	R/W	
C06E	FDSP_SL_P0_0	[7:0]	FDSP_SL_P0[7:0]								0x00	R/W	
C06F	FDSP_SL_P1_3	[7:0]	FDSP_SL_P1[31:24]								0x00	R/W	
C070	FDSP_SL_P1_2	[7:0]	FDSP_SL_P1[23:16]								0x00	R/W	
C071	FDSP_SL_P1_1	[7:0]	FDSP_SL_P1[15:8]								0x00	R/W	
C072	FDSP_SL_P1_0	[7:0]	FDSP_SL_P1[7:0]								0x00	R/W	
C073	FDSP_SL_P2_3	[7:0]	FDSP_SL_P2[31:24]								0x00	R/W	
C074	FDSP_SL_P2_2	[7:0]	FDSP_SL_P2[23:16]								0x00	R/W	
C075	FDSP_SL_P2_1	[7:0]	FDSP_SL_P2[15:8]								0x00	R/W	
C076	FDSP_SL_P2_0	[7:0]	FDSP_SL_P2[7:0]								0x00	R/W	
C077	FDSP_SL_P3_3	[7:0]	FDSP_SL_P3[31:24]								0x00	R/W	
C078	FDSP_SL_P3_2	[7:0]	FDSP_SL_P3[23:16]								0x00	R/W	
C079	FDSP_SL_P3_1	[7:0]	FDSP_SL_P3[15:8]								0x00	R/W	
C07A	FDSP_SL_P3_0	[7:0]	FDSP_SL_P3[7:0]								0x00	R/W	
C07B	FDSP_SL_P4_3	[7:0]	FDSP_SL_P4[31:24]								0x00	R/W	
C07C	FDSP_SL_P4_2	[7:0]	FDSP_SL_P4[23:16]								0x00	R/W	
C07D	FDSP_SL_P4_1	[7:0]	FDSP_SL_P4[15:8]								0x00	R/W	
C07E	FDSP_SL_P4_0	[7:0]	FDSP_SL_P4[7:0]								0x00	R/W	
C07F	FDSP_SL_UPDATE	[7:0]	RESERVED								FDSP_SL_UPDATE	0x00	W
C080	SDSP_CTRL1	[7:0]	RESERVED			SDSP_SPEED		SDSP_RATE_SOURCE			0x00	R/W	
C081	SDSP_CTRL2	[7:0]	RESERVED								SDSP_RUN	0x00	R/W
C082	SDSP_CTRL3	[7:0]	RESERVED			SDSP_WDOG_MUTE		RESERVED			SDSP_WDOG_EN	0x00	R/W
C083	SDSP_CTRL4	[7:0]	SDSP_WDOG_VAL[23:16]								0x00	R/W	
C084	SDSP_CTRL5	[7:0]	SDSP_WDOG_VAL[15:8]								0x00	R/W	
C085	SDSP_CTRL6	[7:0]	SDSP_WDOG_VAL[7:0]								0x00	R/W	
C086	SDSP_CTRL7	[7:0]	RESERVED				SDSP_MOD_DATA_MEM[11:8]				0x07	R/W	
C087	SDSP_CTRL8	[7:0]	SDSP_MOD_DATA_MEM[7:0]								0xF4	R/W	
C088	SDSP_CTRL9	[7:0]	SDSP_RATE_DIV[15:8]								0x07	R/W	
C089	SDSP_CTRL10	[7:0]	SDSP_RATE_DIV[7:0]								0xFF	R/W	
C08A	SDSP_CTRL11	[7:0]	RESERVED				SDSP_INT3	SDSP_INT2	SDSP_INT1	SDSP_INT0	0x00	W	
C08B	MP_CTRL1	[7:0]	MP1_MODE				MP0_MODE				0x00	R/W	
C08C	MP_CTRL2	[7:0]	MP3_MODE				MP2_MODE				0x00	R/W	
C08D	MP_CTRL3	[7:0]	MP5_MODE				MP4_MODE				0x00	R/W	
C08E	MP_CTRL4	[7:0]	MP7_MODE				MP6_MODE				0x00	R/W	

Reg. (Hex.)	Name	Bits	Bit 7	Bit 6	Bit 5	Bit 4	Bit 3	Bit 2	Bit 1	Bit 0	Reset	R/W
C08F	MP_CTRL5	[7:0]	MP9_MODE				MP8_MODE				0x00	R/W
C090	MP_CTRL6	[7:0]	RESERVED				MP10_MODE				0x00	R/W
C091	MP_CTRL7	[7:0]	RESERVED	MCLKO_RATE			RESERVED	GPI_DB			0x10	R/W
C092	MP_CTRL8	[7:0]	GPIO7_OUT	GPIO6_OUT	GPIO5_OUT	GPIO4_OUT	GPIO3_OUT	GPIO2_OUT	GPIO1_OUT	GPIO0_OUT	0x00	R/W
C093	MP_CTRL9	[7:0]	RESERVED				GPIO10_OUT	GPIO9_OUT	GPIO8_OUT		0x00	R/W
C094	FSYNC0_CTRL	[7:0]	RESERVED		FSYNC0_PULL_SEL	FSYNC0_PULL_EN	RESERVED	FSYNC0_SLEW	FSYNC0_DRIVE		0x05	R/W
C095	BCLK0_CTRL	[7:0]	RESERVED		BCLK0_PULL_SEL	BCLK0_PULL_EN	RESERVED	BCLK0_SLEW	BCLK0_DRIVE		0x05	R/W
C096	SDATA00_CTRL	[7:0]	RESERVED				SDATA00_SLEW	RESERVED	SDATA00_DRIVE		0x04	R/W
C097	SDATA10_CTRL	[7:0]	RESERVED		SDATA10_PULL_SEL	SDATA10_PULL_EN	RESERVED	SDATA10_SLEW	SDATA10_DRIVE		0x05	R/W
C098	MP3_CTRL	[7:0]	RESERVED		MP3_PULL_SEL	MP3_PULL_EN	RESERVED	MP3_SLEW	MP3_DRIVE		0x05	R/W
C099	MP4_CTRL	[7:0]	RESERVED		MP4_PULL_SEL	MP4_PULL_EN	RESERVED	MP4_SLEW	MP4_DRIVE		0x05	R/W
C09A	MP5_CTRL	[7:0]	RESERVED		MP5_PULL_SEL	MP5_PULL_EN	RESERVED	MP5_SLEW	MP5_DRIVE		0x05	R/W
C09B	MP6_CTRL	[7:0]	RESERVED		MP6_PULL_SEL	MP6_PULL_EN	RESERVED	MP6_SLEW	MP6_DRIVE		0x05	R/W
C09C	DMIC_CLK0_CTRL	[7:0]	RESERVED		DMIC_CLK0_PULL_SEL	DMIC_CLK0_PULL_EN	RESERVED	DMIC_CLK0_SLEW	DMIC_CLK0_DRIVE		0x05	R/W
C09D	DMIC_CLK1_CTRL	[7:0]	RESERVED		DMIC_CLK1_PULL_SEL	DMIC_CLK1_PULL_EN	RESERVED	DMIC_CLK1_SLEW	DMIC_CLK1_DRIVE		0x05	R/W
C09E	DMIC01_CTRL	[7:0]	RESERVED		DMIC01_PULL_SEL	DMIC01_PULL_EN	RESERVED	DMIC01_SLEW	DMIC01_DRIVE		0x05	R/W
C09F	DMIC23_CTRL	[7:0]	RESERVED		DMIC23_PULL_SEL	DMIC23_PULL_EN	RESERVED	DMIC23_SLEW	DMIC23_DRIVE		0x05	R/W
COA0	I2C_SPI_CTRL	[7:0]	RESERVED						SCL_SCLK_DRIVE	SDA_MISO_DRIVE	0x00	R/W
COA1	IRQ_CTRL1	[7:0]	RESERVED		IRQ_FUNC	IRQ1_FUNC	RESERVED		IRQ2_CLEAR	IRQ1_CLEAR	0x00	R/W
COA2	IRQ1_MASK1	[7:0]	RESERVED		IRQ1_ADC1_CLIP_MASK	IRQ1_ADC0_CLIP_MASK	RESERVED			IRQ1_DAC0_CLIP_MASK	0xF3	R/W
COA3	IRQ1_MASK2	[7:0]	IRQ1_ASRCO_UNLOCKED_MASK	IRQ1_ASRCO_LOCKED_MASK	IRQ1_ASRCI_UNLOCKED_MASK	IRQ1_ASRCI_LOCKED_MASK	IRQ1_PRAMP_MASK	IRQ1_AVDD_UVW_MASK	IRQ1_PLL_UNLOCKED_MASK	IRQ1_PLL_LOCKED_MASK	0xFF	R/W
COA4	IRQ1_MASK3	[7:0]	RESERVED			IRQ1_POWER_UP_COMPLETE_MASK	IRQ1_SDSP3_MASK	IRQ1_SDSP2_MASK	IRQ1_SDSP1_MASK	IRQ1_SDSP0_MASK	0x1F	R/W
COA5	IRQ2_MASK1	[7:0]	RESERVED		IRQ2_ADC1_CLIP_MASK	IRQ2_ADC0_CLIP_MASK	RESERVED			IRQ2_DAC0_CLIP_MASK	0xF3	R/W
COA6	IRQ2_MASK2	[7:0]	IRQ2_ASRCO_UNLOCKED_MASK	IRQ2_ASRCO_LOCKED_MASK	IRQ2_ASRCI_UNLOCKED_MASK	IRQ2_ASRCI_LOCKED_MASK	IRQ2_PRAMP_MASK	IRQ2_AVDD_UVW_MASK	IRQ2_PLL_UNLOCKED_MASK	IRQ2_PLL_LOCKED_MASK	0xFF	R/W
COA7	IRQ2_MASK3	[7:0]	RESERVED			IRQ2_POWER_UP_COMPLETE_MASK	IRQ2_SDSP3_MASK	IRQ2_SDSP2_MASK	IRQ2_SDSP1_MASK	IRQ2_SDSP0_MASK	0x1F	R/W
COA8	RESETS	[7:0]	RESERVED			SOFT_RESET	RESERVED			SOFT_FULL_RESET	0x00	W
COA9	READ_LAMBDA	[7:0]	RESERVED		FDSP_CURRENT_LAMBDA					0x3F	R	

Reg. (Hex.)	Name	Bits	Bit 7	Bit 6	Bit 5	Bit 4	Bit 3	Bit 2	Bit 1	Bit 0	Reset	R/W	
C0AA	STATUS1	[7:0]	RESERVED		ADC1_CLIP	ADC0_CLIP	RESERVED			DAC0_CLIP	0x00	R	
C0AB	STATUS2	[7:0]	POWER_UP_COMPLETE	SYNC_LOCK	RESERVED	SPT0_LOCK	ASRCO_LOCK	ASRCL_LOCK	AVDD_UVW	PLL_LOCK	0x00	R	
C0AC	GPI1	[7:0]	GPIO7_IN	GPIO6_IN	GPIO5_IN	GPIO4_IN	GPIO3_IN	GPIO2_IN	GPIO1_IN	GPIO0_IN	0x00	R	
C0AD	GPI2	[7:0]	RESERVED					GPIO10_IN	GPIO9_IN	GPIO8_IN	0x00	R	
C0AE	DSP_STATUS	[7:0]	RESERVED							SDSP_WDOG_ERROR	0x00	R	
C0AF	IRQ1_STATUS1	[7:0]	RESERVED		IRQ1_ADC1_CLIP	IRQ1_ADC0_CLIP	RESERVED			IRQ1_DAC0_CLIP	0x00	R	
C0B0	IRQ1_STATUS2	[7:0]	IRQ1_ASRCO_UNLOCKED	IRQ1_ASRCL_LOCKED	IRQ1_ASRCI_UNLOCKED	IRQ1_ASRCL_LOCKED	IRQ1_PRAMP	IRQ1_AVDD_UVW	IRQ1_PLL_UNLOCKED	IRQ1_PLL_LOCKED	0x00	R	
C0B1	IRQ1_STATUS3	[7:0]	RESERVED			IRQ1_POWER_UP_COMPLETE	IRQ1_SDSP3	IRQ1_SDSP2	IRQ1_SDSP1	IRQ1_SDSP0	0x00	R	
C0B2	IRQ2_STATUS1	[7:0]	RESERVED		IRQ2_ADC1_CLIP	IRQ2_ADC0_CLIP	RESERVED			IRQ2_DAC0_CLIP	0x00	R	
C0B3	IRQ2_STATUS2	[7:0]	IRQ2_ASRCO_UNLOCKED	IRQ2_ASRCL_LOCKED	IRQ2_ASRCI_UNLOCKED	IRQ2_ASRCL_LOCKED	IRQ2_PRAMP	IRQ2_AVDD_UVW	IRQ2_PLL_UNLOCKED	IRQ2_PLL_LOCKED	0x00	R	
C0B4	IRQ2_STATUS3	[7:0]	RESERVED			IRQ2_POWER_UP_COMPLETE	IRQ2_SDSP3	IRQ2_SDSP2	IRQ2_SDSP1	IRQ2_SDSP0	0x00	R	
C0B5	SPT0_CTRL1	[7:0]	RESERVED	SPT0_TRI_STATE	SPT0_SLOT_WIDTH		SPT0_DATA_FORMAT			SPT0_SAI_MODE	0x00	R/W	
C0B6	SPT0_CTRL2	[7:0]	SPT0_LRCLK_POL	SPT0_LRCLK_SRC			SPT0_BCLK_POL	SPT0_BCLK_SRC			0x00	R/W	
C0B7	SPT0_ROUTE0	[7:0]	RESERVED			SPT0_OUT_ROUTE0					0x10	R/W	
C0B8	SPT0_ROUTE1	[7:0]	RESERVED			SPT0_OUT_ROUTE1					0x11	R/W	
C0B9	SPT0_ROUTE2	[7:0]	RESERVED			SPT0_OUT_ROUTE2					0x3F	R/W	
C0BA	SPT0_ROUTE3	[7:0]	RESERVED			SPT0_OUT_ROUTE3					0x3F	R/W	
C0BB	SPT0_ROUTE4	[7:0]	RESERVED			SPT0_OUT_ROUTE4					0x3F	R/W	
C0BC	SPT0_ROUTE5	[7:0]	RESERVED			SPT0_OUT_ROUTE5					0x3F	R/W	
C0BD	SPT0_ROUTE6	[7:0]	RESERVED			SPT0_OUT_ROUTE6					0x3F	R/W	
C0BE	SPT0_ROUTE7	[7:0]	RESERVED			SPT0_OUT_ROUTE7					0x3F	R/W	
C0BF	SPT0_ROUTE8	[7:0]	RESERVED			SPT0_OUT_ROUTE8					0x3F	R/W	
C0C0	SPT0_ROUTE9	[7:0]	RESERVED			SPT0_OUT_ROUTE9					0x3F	R/W	
C0C1	SPT0_ROUTE10	[7:0]	RESERVED			SPT0_OUT_ROUTE10					0x3F	R/W	
C0C2	SPT0_ROUTE11	[7:0]	RESERVED			SPT0_OUT_ROUTE11					0x3F	R/W	
C0C3	SPT0_ROUTE12	[7:0]	RESERVED			SPT0_OUT_ROUTE12					0x3F	R/W	
C0C4	SPT0_ROUTE13	[7:0]	RESERVED			SPT0_OUT_ROUTE13					0x3F	R/W	
C0C5	SPT0_ROUTE14	[7:0]	RESERVED			SPT0_OUT_ROUTE14					0x3F	R/W	
C0C6	SPT0_ROUTE15	[7:0]	RESERVED			SPT0_OUT_ROUTE15					0x3F	R/W	
C0DC	PDM_CTRL1	[7:0]	PDM_MORE_FILTER	RESERVED		PDM_RATE	PDM_FCOMP	PDM_FS				0x02	R/W
C0DD	PDM_CTRL2	[7:0]	PDM1_MUTE	PDM0_MUTE	PDM1_HPF_EN	PDM0_HPF_EN	RESERVED	PDM_VOL_ZC	PDM_HARD_VOL	PDM_VOL_LINK	0xC4	R/W	



Reg. (Hex.)	Name	Bits	Bit 7	Bit 6	Bit 5	Bit 4	Bit 3	Bit 2	Bit 1	Bit 0	Reset	R/W	
CODE	PDM_VOL0	[7:0]	PDM0_VOL									0x40	R/W
CODF	PDM_VOL1	[7:0]	PDM1_VOL									0x40	R/W
COE0	PDM_ROUTE0	[7:0]	RESERVED	PDM0_ROUTE								0x00	R/W
COE1	PDM_ROUTE1	[7:0]	RESERVED	PDM1_ROUTE								0x01	R/W

## REGISTER DETAILS

### ANALOG DEVICES VENDOR ID REGISTER

Address: 0xC000, Reset: 0x41, Name: VENDOR\_ID

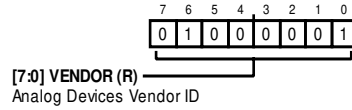

Table 38. Bit Descriptions for VENDOR\_ID

Bits	Bit Name	Settings	Description	Reset	Access
[7:0]	VENDOR		Analog Devices Vendor ID	0x41	R

### DEVICE ID REGISTERS

Address: 0xC001, Reset: 0x17, Name: DEVICE\_ID1

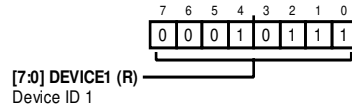

Table 39. Bit Descriptions for DEVICE\_ID1

Bits	Bit Name	Settings	Description	Reset	Access
[7:0]	DEVICE1		Device ID 1	0x17	R

Address: 0xC002, Reset: 0x87, Name: DEVICE\_ID2

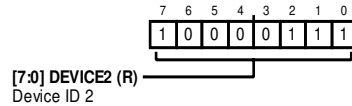

Table 40. Bit Descriptions for DEVICE\_ID2

Bits	Bit Name	Settings	Description	Reset	Access
[7:0]	DEVICE2		Device ID 2	0x87	R

### REVISION CODE REGISTER

Address: 0xC003, Reset: 0x01, Name: REVISION

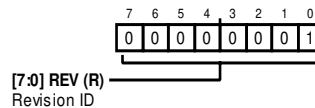

Table 41. Bit Descriptions for REVISION

Bits	Bit Name	Settings	Description	Reset	Access
[7:0]	REV		Revision ID	0x1	R

### ADC, DAC, AND HEADPHONE POWER CONTROLS REGISTER

Address: 0xC004, Reset: 0x00, Name: ADC\_DAC\_HP\_PWR

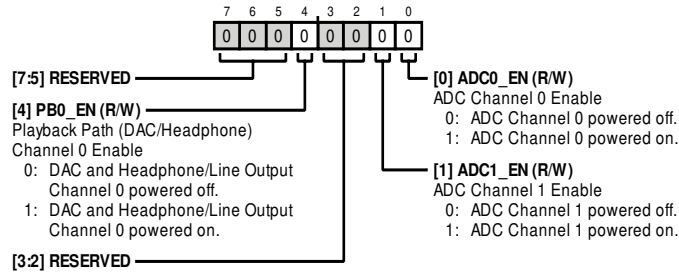

Table 42. Bit Descriptions for ADC\_DAC\_HP\_PWR

Bits	Bit Name	Settings	Description	Reset	Access
[7:5]	RESERVED		Reserved.	0x0	R
4	PBO_EN	0 1	Playback Path (DAC/Headphone) Channel 0 Enable. 0 DAC and Headphone/Line Output Channel 0 powered off. 1 DAC and Headphone/Line Output Channel 0 powered on.	0x0	R/W
[3:2]	RESERVED		Reserved.	0x0	R/W
1	ADC1_EN	0 1	ADC Channel 1 Enable. 0 ADC Channel 1 powered off. 1 ADC Channel 1 powered on.	0x0	R/W
0	ADC0_EN	0 1	ADC Channel 0 Enable. 0 ADC Channel 0 powered off. 1 ADC Channel 0 powered on.	0x0	R/W

### PLL, MICROPHONE BIAS, AND PGA POWER CONTROLS REGISTER

Address: 0xC005, Reset: 0x02, Name: PLL\_MB\_PGA\_PWR

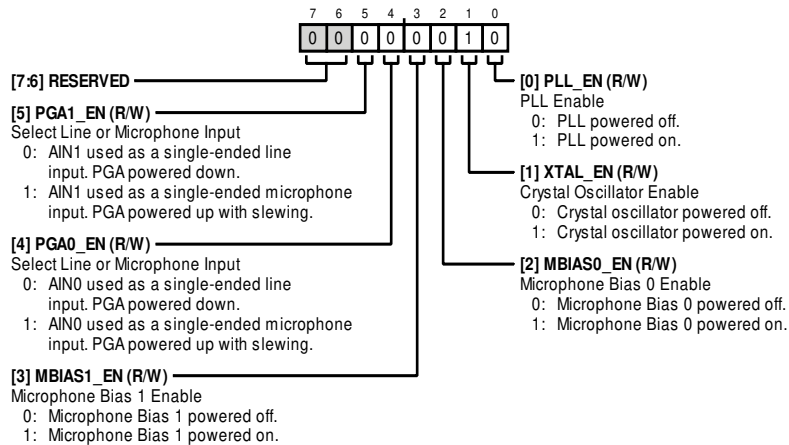

Table 43. Bit Descriptions for PLL\_MB\_PGA\_PWR

Bits	Bit Name	Settings	Description	Reset	Access
[7:6]	RESERVED		Reserved.	0x0	R/W
5	PGA1_EN	0 1	Select Line or Microphone Input. The PGA inverts the signal going through it. 0 AIN1 used as a single-ended line input. PGA powered down. 1 AIN1 used as a single-ended microphone input. PGA powered up with slewing.	0x0	R/W
4	PGA0_EN	0 1	Select Line or Microphone Input. The PGA inverts the signal going through it. 0 AIN0 used as a single-ended line input. PGA powered down. 1 AIN0 used as a single-ended microphone input. PGA powered up with slewing.	0x0	R/W

Bits	Bit Name	Settings	Description	Reset	Access
3	MBIAS1_EN	0 1	Microphone Bias 1 Enable. Microphone Bias 1 powered off. Microphone Bias 1 powered on.	0x0	R/W
2	MBIAS0_EN	0 1	Microphone Bias 0 Enable. Microphone Bias 0 powered off. Microphone Bias 0 powered on.	0x0	R/W
1	XTAL_EN	0 1	Crystal Oscillator Enable. Crystal oscillator powered off. Crystal oscillator powered on.	0x1	R/W
0	PLL_EN	0 1	PLL Enable. PLL powered off. PLL powered on.	0x0	R/W

**DIGITAL MICROPHONE POWER CONTROLS REGISTER**

Address: 0xC006, Reset: 0x00, Name: DMIC\_PWR

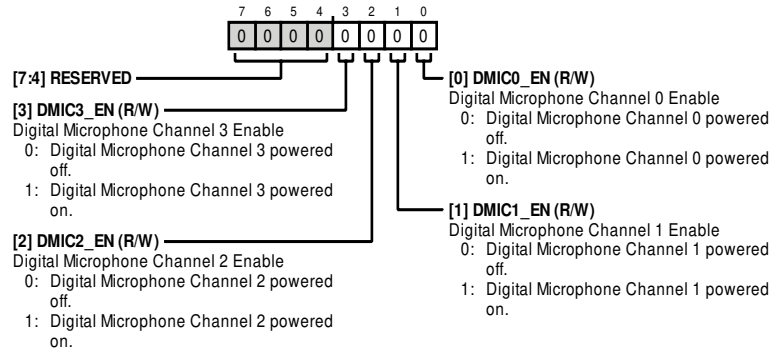
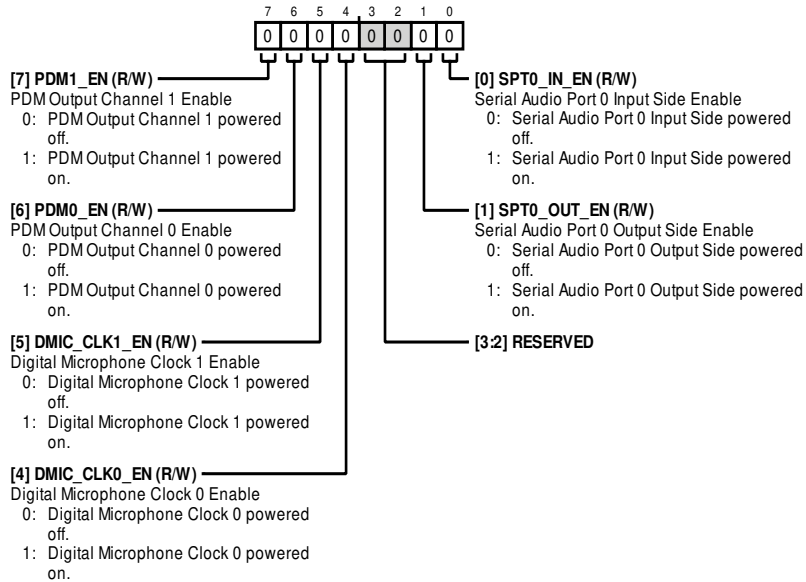

Table 44. Bit Descriptions for DMIC\_PWR

Bits	Bit Name	Settings	Description	Reset	Access
[7:4]	RESERVED		Reserved.	0x0	R/W
3	DMIC3_EN	0 1	Digital Microphone Channel 3 Enable. Digital Microphone Channel 3 powered off. Digital Microphone Channel 3 powered on.	0x0	R/W
2	DMIC2_EN	0 1	Digital Microphone Channel 2 Enable. Digital Microphone Channel 2 powered off. Digital Microphone Channel 2 powered on.	0x0	R/W
1	DMIC1_EN	0 1	Digital Microphone Channel 1 Enable. Digital Microphone Channel 1 powered off. Digital Microphone Channel 1 powered on.	0x0	R/W
0	DMIC0_EN	0 1	Digital Microphone Channel 0 Enable. Digital Microphone Channel 0 powered off. Digital Microphone Channel 0 powered on.	0x0	R/W

**SERIAL PORT, PDM OUTPUT, AND DIGITAL MICROPHONE CLOCK POWER CONTROLS REGISTER**

Address: 0xC007, Reset: 0x00, Name: SAI\_CLK\_PWR



**Table 45. Bit Descriptions for SAI\_CLK\_PWR**

Bits	Bit Name	Settings	Description	Reset	Access
7	PDM1_EN	0 1	PDM Output Channel 1 Enable. PDM Output Channel 1 powered off. PDM Output Channel 1 powered on.	0x0	R/W
6	PDM0_EN	0 1	PDM Output Channel 0 Enable. PDM Output Channel 0 powered off. PDM Output Channel 0 powered on.	0x0	R/W
5	DMIC_CLK1_EN	0 1	Digital Microphone Clock 1 Enable. Digital Microphone Clock 1 powered off. Digital Microphone Clock 1 powered on.	0x0	R/W
4	DMIC_CLK0_EN	0 1	Digital Microphone Clock 0 Enable. Digital Microphone Clock 0 powered off. Digital Microphone Clock 0 powered on.	0x0	R/W
[3:2]	RESERVED		Reserved.	0x0	R/W
1	SPT0_OUT_EN	0 1	Serial Audio Port 0 Output Side Enable. Serial Audio Port 0 Output Side powered off. Serial Audio Port 0 Output Side powered on.	0x0	R/W
0	SPT0_IN_EN	0 1	Serial Audio Port 0 Input Side Enable. Serial Audio Port 0 Input Side powered off. Serial Audio Port 0 Input Side powered on.	0x0	R/W

**DSP POWER CONTROLS REGISTER**

Address: 0xC008, Reset: 0x00, Name: DSP\_PWR

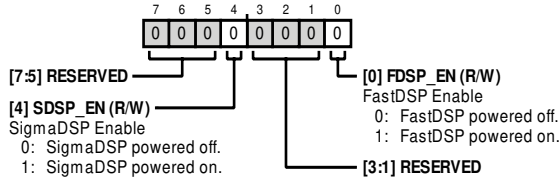

Table 46. Bit Descriptions for DSP\_PWR

Bits	Bit Name	Settings	Description	Reset	Access
[7:5]	RESERVED		Reserved.	0x0	R
4	SDSP_EN	0 1	SigmaDSP Enable. SigmaDSP powered off.. SigmaDSP powered on.	0x0	R/W
[3:1]	RESERVED		Reserved.	0x0	R
0	FDSP_EN	0 1	FastDSP Enable. FastDSP powered off.. FastDSP powered on.	0x0	R/W

**ASRC POWER CONTROLS REGISTER**

Address: 0xC009, Reset: 0x00, Name: ASRC\_PWR

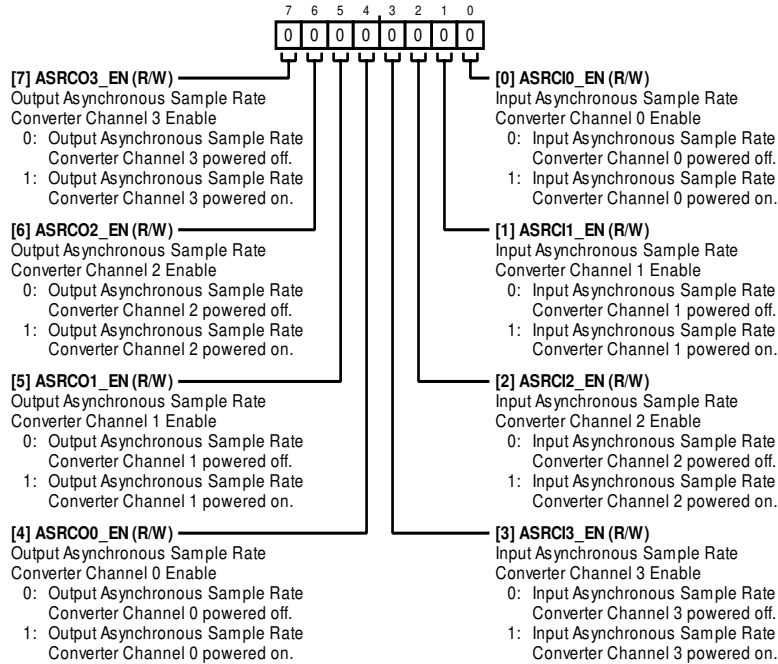

Table 47. Bit Descriptions for ASRC\_PWR

Bits	Bit Name	Settings	Description	Reset	Access
7	ASRC03_EN	0 1	Output Asynchronous Sample Rate Converter Channel 3 Enable. Output Asynchronous Sample Rate Converter Channel 3 powered off. Output Asynchronous Sample Rate Converter Channel 3 powered on.	0x0	R/W
6	ASRC02_EN	0 1	Output Asynchronous Sample Rate Converter Channel 2 Enable. Output Asynchronous Sample Rate Converter Channel 2 powered off. Output Asynchronous Sample Rate Converter Channel 2 powered on.	0x0	R/W

Bits	Bit Name	Settings	Description	Reset	Access
5	ASRCO1_EN		Output Asynchronous Sample Rate Converter Channel 1 Enable.	0x0	R/W
		0	Output Asynchronous Sample Rate Converter Channel 1 powered off.		
		1	Output Asynchronous Sample Rate Converter Channel 1 powered on.		
4	ASRCO0_EN		Output Asynchronous Sample Rate Converter Channel 0 Enable.	0x0	R/W
		0	Output Asynchronous Sample Rate Converter Channel 0 powered off.		
		1	Output Asynchronous Sample Rate Converter Channel 0 powered on.		
3	ASRCI3_EN		Input Asynchronous Sample Rate Converter Channel 3 Enable.	0x0	R/W
		0	Input Asynchronous Sample Rate Converter Channel 3 powered off.		
		1	Input Asynchronous Sample Rate Converter Channel 3 powered on.		
2	ASRCI2_EN		Input Asynchronous Sample Rate Converter Channel 2 Enable.	0x0	R/W
		0	Input Asynchronous Sample Rate Converter Channel 2 powered off.		
		1	Input Asynchronous Sample Rate Converter Channel 2 powered on.		
1	ASRCI1_EN		Input Asynchronous Sample Rate Converter Channel 1 Enable.	0x0	R/W
		0	Input Asynchronous Sample Rate Converter Channel 1 powered off.		
		1	Input Asynchronous Sample Rate Converter Channel 1 powered on.		
0	ASRCIO_EN		Input Asynchronous Sample Rate Converter Channel 0 Enable.	0x0	R/W
		0	Input Asynchronous Sample Rate Converter Channel 0 powered off.		
		1	Input Asynchronous Sample Rate Converter Channel 0 powered on.		

**INTERPOLATOR POWER CONTROLS REGISTER**

Address: 0xC00A, Reset: 0x00, Name: FINT\_PWR

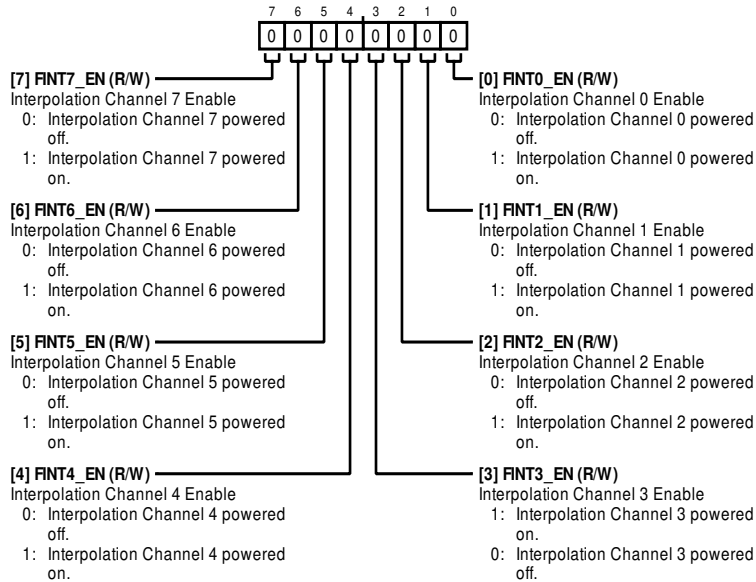

Table 48. Bit Descriptions for FINT\_PWR

Bits	Bit Name	Settings	Description	Reset	Access
7	FINT7_EN	0 1	Interpolation Channel 7 Enable. Interpolation Channel 7 powered off. Interpolation Channel 7 powered on.	0x0	R/W
6	FINT6_EN	0 1	Interpolation Channel 6 Enable. Interpolation Channel 6 powered off. Interpolation Channel 6 powered on.	0x0	R/W
5	FINT5_EN	0 1	Interpolation Channel 5 Enable. Interpolation Channel 5 powered off. Interpolation Channel 5 powered on.	0x0	R/W
4	FINT4_EN	0 1	Interpolation Channel 4 Enable. Interpolation Channel 4 powered off. Interpolation Channel 4 powered on.	0x0	R/W
3	FINT3_EN	0 1	Interpolation Channel 3 Enable. Interpolation Channel 3 powered off. Interpolation Channel 3 powered on.	0x0	R/W
2	FINT2_EN	0 1	Interpolation Channel 2 Enable. Interpolation Channel 2 powered off. Interpolation Channel 2 powered on.	0x0	R/W
1	FINT1_EN	0 1	Interpolation Channel 1 Enable. Interpolation Channel 1 powered off. Interpolation Channel 1 powered on.	0x0	R/W
0	FINT0_EN	0 1	Interpolation Channel 0 Enable. Interpolation Channel 0 powered off. Interpolation Channel 0 powered on.	0x0	R/W



**DECIMATOR POWER CONTROLS REGISTER**

Address: 0xC00B, Reset: 0x00, Name: FDEC\_PWR

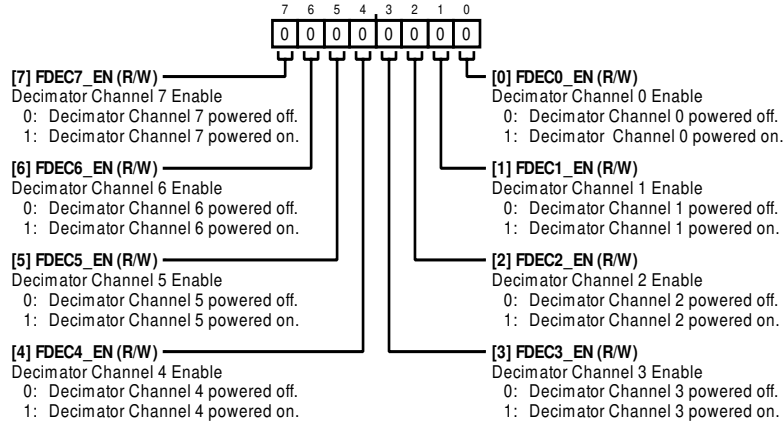
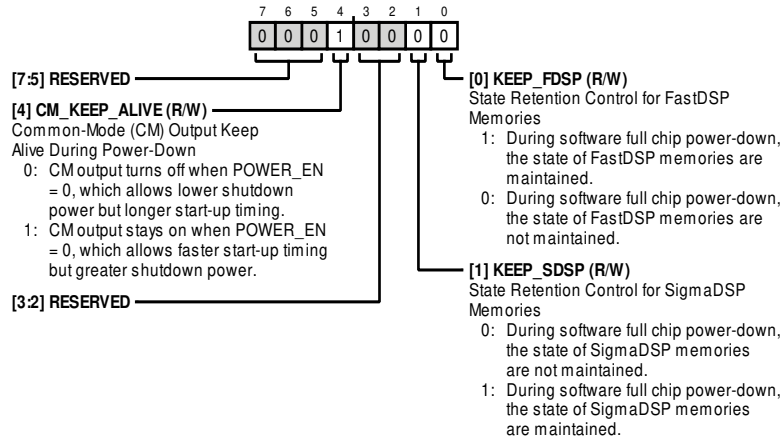

Table 49. Bit Descriptions for FDEC\_PWR

Bits	Bit Name	Settings	Description	Reset	Access
7	FDEC7_EN	0 1	Decimator Channel 7 Enable. Decimator Channel 7 powered off. Decimator Channel 7 powered on.	0x0	R/W
6	FDEC6_EN	0 1	Decimator Channel 6 Enable. Decimator Channel 6 powered off. Decimator Channel 6 powered on.	0x0	R/W
5	FDEC5_EN	0 1	Decimator Channel 5 Enable. Decimator Channel 5 powered off. Decimator Channel 5 powered on.	0x0	R/W
4	FDEC4_EN	0 1	Decimator Channel 4 Enable. Decimator Channel 4 powered off. Decimator Channel 4 powered on.	0x0	R/W
3	FDEC3_EN	0 1	Decimator Channel 3 Enable. Decimator Channel 3 powered off. Decimator Channel 3 powered on.	0x0	R/W
2	FDEC2_EN	0 1	Decimator Channel 2 Enable. Decimator Channel 2 powered off. Decimator Channel 2 powered on.	0x0	R/W
1	FDEC1_EN	0 1	Decimator Channel 1 Enable. Decimator Channel 1 powered off. Decimator Channel 1 powered on.	0x0	R/W
0	FDEC0_EN	0 1	Decimator Channel 0 Enable. Decimator Channel 0 powered off. Decimator Channel 0 powered on.	0x0	R/W

**STATE RETENTION CONTROLS REGISTER**

Address: 0xC00C, Reset: 0x10, Name: KEEPS



**Table 50. Bit Descriptions for KEEPS**

Bits	Bit Name	Settings	Description	Reset	Access
[7:5]	RESERVED		Reserved.	0x0	R
4	CM_KEEP_ALIVE	0 1	Common-Mode (CM) Output Keep Alive During Power-Down. 0 CM output turns off when POWER_EN = 0, which allows lower shutdown power but longer start-up timing. 1 CM output stays on when POWER_EN = 0, which allows faster start-up timing but greater shutdown power.	0x1	R/W
[3:2]	RESERVED		Reserved.	0x0	R
1	KEEP_SDSP	0 1	State Retention Control for SigmaDSP Memories. 0 During software full chip power-down, the state of SigmaDSP memories are not maintained. 1 During software full chip power-down, the state of SigmaDSP memories are maintained.	0x0	R/W
0	KEEP_FDSP	1 0	State Retention Control for FastDSP Memories. 1 During software full chip power-down, the state of FastDSP memories are maintained. 0 During software full chip power-down, the state of FastDSP memories are not maintained.	0x0	R/W

**CHIP POWER CONTROL REGISTER**

Address: 0xC00D, Reset: 0x10, Name: CHIP\_PWR

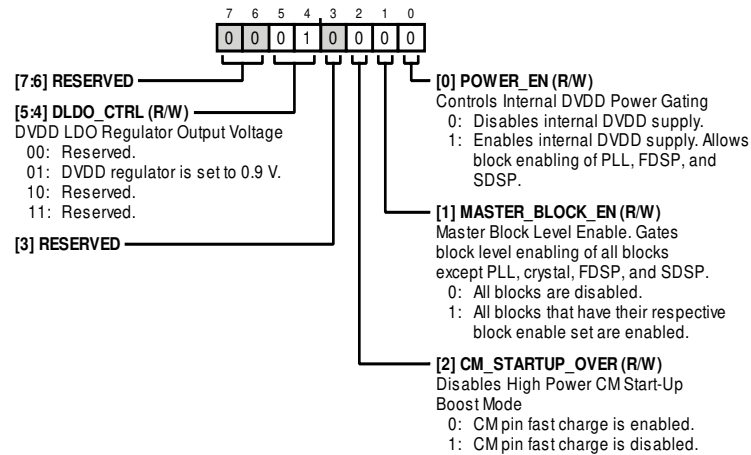

Table 51. Bit Descriptions for CHIP\_PWR

Bits	Bit Name	Settings	Description	Reset	Access
[7:6]	RESERVED		Reserved.	0x0	R
[5:4]	DLDO_CTRL	00 01 10 11	DVDD LDO Regulator Output Voltage. Reserved. DVDD regulator is set to 0.9 V. Reserved. Reserved.	0x1	R/W
3	RESERVED		Reserved.	0x0	R
2	CM_STARTUP_OVER	0 1	Disables High Power CM Start-Up Boost Mode. CM pin fast charge is enabled. CM pin fast charge is disabled.	0x0	R/W
1	MASTER_BLOCK_EN	0 1	Master Block Level Enable. Gates block level enabling of all blocks except PLL, crystal, FDSP, and SDSP. All blocks are disabled. All blocks that have their respective block enable set are enabled.	0x0	R/W
0	POWER_EN	0 1	Controls Internal DVDD Power Gating Disables internal DVDD supply. Enables internal DVDD supply. Allows block enabling of PLL, FDSP, and SDSP.	0x0	R/W

**CLOCK CONTROL REGISTER**

Address: 0xC00E, Reset: 0xC8, Name: CLK\_CTRL1

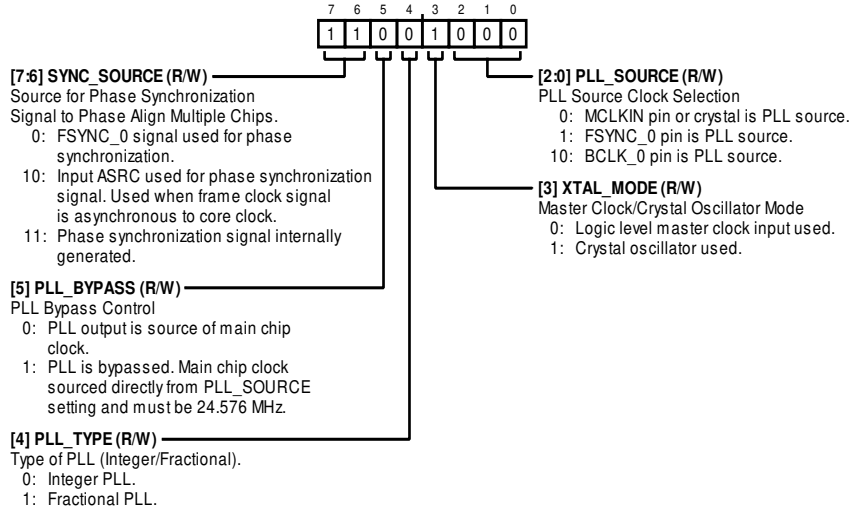

Table 52. Bit Descriptions for CLK\_CTRL1

Bits	Bit Name	Settings	Description	Reset	Access
[7:6]	SYNC_SOURCE	0 10 11	Source for Phase Synchronization Signal to Phase Align Multiple Chips. FSYNC_0 signal used for phase synchronization. Input ASRC used for phase synchronization signal. Used when frame clock signal is asynchronous to core clock. Phase synchronization signal internally generated.	0x3	R/W
5	PLL_BYPASS	0 1	PLL Bypass Control. PLL output is source of main chip clock. PLL is bypassed. Main chip clock sourced directly from PLL_SOURCE setting and must be 24.576 MHz.	0x0	R/W
4	PLL_TYPE	0 1	Type of PLL (Integer/Fractional). Integer PLL. Fractional PLL.	0x0	R/W
3	XTAL_MODE	0 1	Master Clock/Crystal Oscillator Mode. Logic level master clock input used. Crystal oscillator used.	0x1	R/W
[2:0]	PLL_SOURCE	0 1 10	PLL Source Clock Selection. MCLKIN pin or crystal is PLL source. FSYNC_0 pin is PLL source. BCLK_0 pin is PLL source.	0x0	R/W

**PLL INPUT DIVIDER REGISTER**

Address: 0xC00F, Reset: 0x00, Name: CLK\_CTRL2

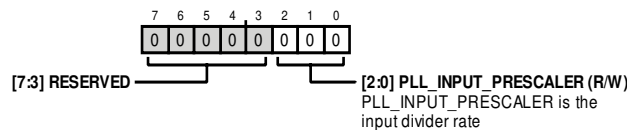

Table 53. Bit Descriptions for CLK\_CTRL2

Bits	Bit Name	Settings	Description	Reset	Access
[7:3]	RESERVED		Reserved.	0x0	R
[2:0]	PLL_INPUT_PRESCALER		PLL_INPUT_PRESCALER is the input divider rate.	0x0	R/W

**PLL FEEDBACK INTEGER DIVIDER (MSBs) REGISTER**

Address: 0xC010, Reset: 0x00, Name: CLK\_CTRL3

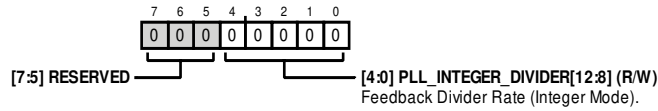

Table 54. Bit Descriptions for CLK\_CTRL3

Bits	Bit Name	Settings	Description	Reset	Access
[7:5]	RESERVED		Reserved.	0x0	R
[4:0]	PLL_INTEGER_DIVIDER[12:8]		Feedback Divider Rate (Integer Mode).	0x0	R/W

**PLL FEEDBACK INTEGER DIVIDER (LSBs) REGISTER**

Address: 0xC011, Reset: 0x02, Name: CLK\_CTRL4

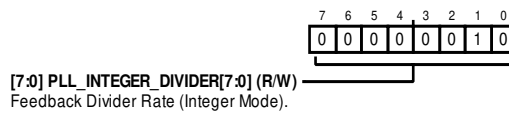

Table 55. Bit Descriptions for CLK\_CTRL4

Bits	Bit Name	Settings	Description	Reset	Access
[7:0]	PLL_INTEGER_DIVIDER[7:0]		Feedback Divider Rate (Integer Mode).	0x2	R/W

**PLL FRACTIONAL NUMERATOR VALUE (MSBs) REGISTER**

Address: 0xC012, Reset: 0x00, Name: CLK\_CTRL5

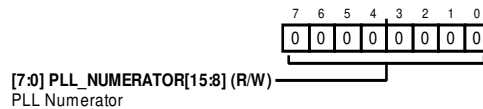

Table 56. Bit Descriptions for CLK\_CTRL5

Bits	Bit Name	Settings	Description	Reset	Access
[7:0]	PLL_NUMERATOR[15:8]		PLL Numerator	0x0	R/W

**PLL FRACTIONAL NUMERATOR VALUE (LSBs) REGISTER**

Address: 0xC013, Reset: 0x00, Name: CLK\_CTRL6

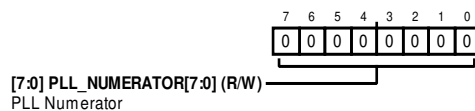

Table 57. Bit Descriptions for CLK\_CTRL6

Bits	Bit Name	Settings	Description	Reset	Access
[7:0]	PLL_NUMERATOR[7:0]		PLL Numerator	0x0	R/W

**PLL FRACTIONAL DENOMINATOR (MSBs) REGISTER**

Address: 0xC014, Reset: 0x00, Name: CLK\_CTRL7

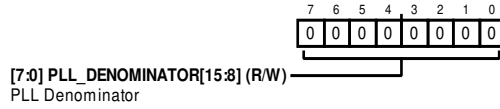

Table 58. Bit Descriptions for CLK\_CTRL7

Bits	Bit Name	Settings	Description	Reset	Access
[7:0]	PLL_DENOMINATOR[15:8]		PLL Denominator	0x0	R/W

**PLL FRACTIONAL DENOMINATOR (LSBs) REGISTER**

Address: 0xC015, Reset: 0x00, Name: CLK\_CTRL8

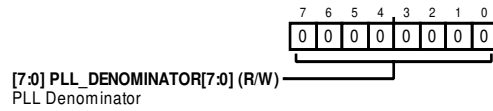

Table 59. Bit Descriptions for CLK\_CTRL8

Bits	Bit Name	Settings	Description	Reset	Access
[7:0]	PLL_DENOMINATOR[7:0]		PLL Denominator	0x0	R/W

**PLL UPDATE REGISTER**

Address: 0xC016, Reset: 0x00, Name: CLK\_CTRL9

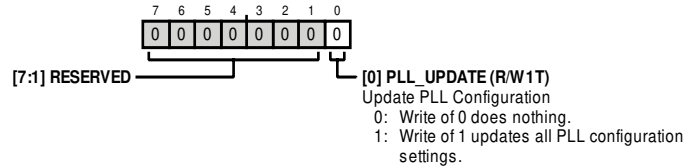

Table 60. Bit Descriptions for CLK\_CTRL9

Bits	Bit Name	Settings	Description	Reset	Access
[7:1]	RESERVED		Reserved.	0x0	R
0	PLL_UPDATE	0 1	Update PLL Configuration. Write of 0 does nothing. Write of 1 updates all PLL configuration settings.	0x0	R/W1T

**ADC SAMPLE RATE CONTROL REGISTER**

Address: 0xC017, Reset: 0x22, Name: ADC\_CTRL1

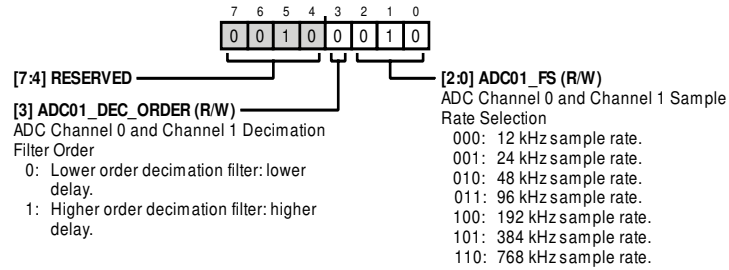

Table 61. Bit Descriptions for ADC\_CTRL1

Bits	Bit Name	Settings	Description	Reset	Access
[7:4]	RESERVED		Reserved.	0x2	R/W
3	ADC01_DEC_ORDER	0 1	ADC Channel 0 and Channel 1 Decimation Filter Order. 0 Lower order decimation filter: lower delay. 1 Higher order decimation filter: higher delay.	0x0	R/W
[2:0]	ADC01_FS	000 001 010 011 100 101 110	ADC Channel 0 and Channel 1 Sample Rate Selection. 12 kHz sample rate. 24 kHz sample rate. 48 kHz sample rate. 96 kHz sample rate. 192 kHz sample rate. 384 kHz sample rate. 768 kHz sample rate.	0x2	R/W

**ADC I<sub>BIAS</sub> CONTROLS REGISTER**

Address: 0xC018, Reset: 0x00, Name: ADC\_CTRL2

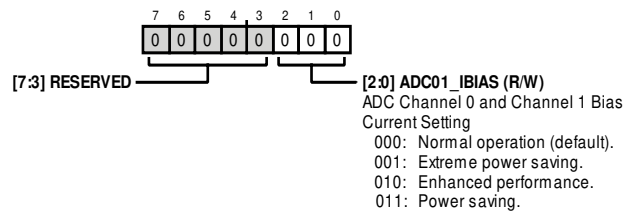
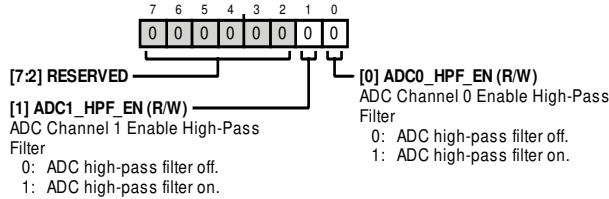

Table 62. Bit Descriptions for ADC\_CTRL2

Bits	Bit Name	Settings	Description	Reset	Access
[7:3]	RESERVED		Reserved.	0x0	R
[2:0]	ADC01_IBIAS	000 001 010 011	ADC Channel 0 and Channel 1 Bias Current Setting. Higher bias currents result in higher performance. 000 Normal operation (default). 001 Extreme power saving. 010 Enhanced performance. 011 Power saving.	0x0	R/W

**ADC HIGH-PASS FILTER CONTROL REGISTER**

Address: 0xC019, Reset: 0x00, Name: ADC\_CTRL3

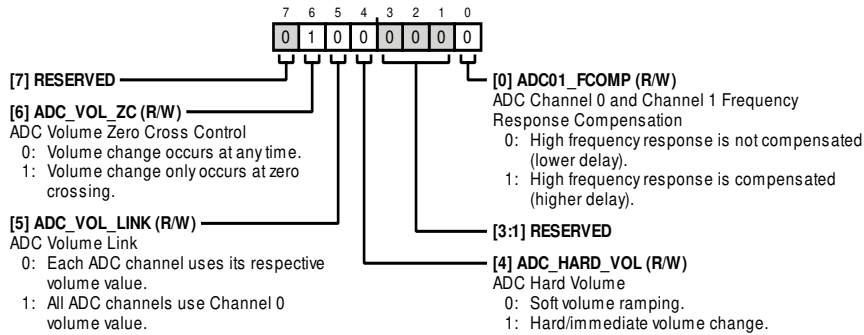

**Table 63. Bit Descriptions for ADC\_CTRL3**

Bits	Bit Name	Settings	Description	Reset	Access
[7:2]	RESERVED		Reserved.	0x0	R
1	ADC1_HP_FEN	0 1	ADC Channel 1 Enable High-Pass Filter. 0: ADC high-pass filter off. 1: ADC high-pass filter on.	0x0	R/W
0	ADC0_HP_FEN	0 1	ADC Channel 0 Enable High-Pass Filter. 0: ADC high-pass filter off. 1: ADC high-pass filter on.	0x0	R/W

**ADC MUTE AND COMPENSATION CONTROL REGISTER**

Address: 0xC01A, Reset: 0x40, Name: ADC\_CTRL4



**Table 64. Bit Descriptions for ADC\_CTRL4**

Bits	Bit Name	Settings	Description	Reset	Access
7	RESERVED		Reserved.	0x0	R
6	ADC_VOL_ZC	0 1	ADC Volume Zero Cross Control. 0: Volume change occurs at any time. 1: Volume change only occurs at zero crossing.	0x1	R/W
5	ADC_VOL_LINK	0 1	ADC Volume Link. 0: Each ADC channel uses its respective volume value. 1: All ADC channels use Channel 0 volume value.	0x0	R/W
4	ADC_HARD_VOL	0 1	ADC Hard Volume. 0: Soft volume ramping. 1: Hard/immediate volume change.	0x0	R/W
[3:1]	RESERVED		Reserved.	0x0	R
0	ADC01_FCOMP	0 1	ADC Channel 0 and Channel 1 Frequency Response Compensation. 0: High frequency response is not compensated (lower delay). 1: High frequency response is compensated (higher delay).	0x0	R/W



**ANALOG INPUT PRECHARGE TIME REGISTER**

Address: 0xC01B, Reset: 0x26, Name: ADC\_CTRL5

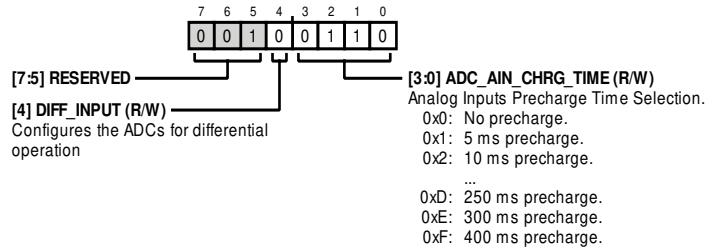

**Table 65. Bit Descriptions for ADC\_CTRL5**

Bits	Bit Name	Settings	Description	Reset	Access
[7:5]	RESERVED		Reserved.	0x1	R
4	DIFF_INPUT		Configures the ADCs for differential operation.	0x0	R/W
[3:0]	ADC_AIN_CHRG_TIME		Analog Inputs Precharge Time Selection. Controls the amount of time the precharge circuit is used to charge up the coupling capacitors. The time used depends on the value of the capacitor used and the required start-up time of the ADC.	0x6	R/W
		0x0	No Precharge.		
		0x1	5 ms precharge.		
		0x2	10 ms precharge.		
		0x3	20 ms precharge.		
		0x4	30 ms precharge.		
		0x5	40 ms precharge.		
		0x6	50 ms precharge.		
		0x7	60 ms precharge.		
		0x8	80 ms precharge.		
		0x9	100 ms precharge.		
		0xA	125 ms precharge.		
		0xB	150 ms precharge.		
		0xC	200 ms precharge.		
		0xD	250 ms precharge.		
		0xE	300 ms precharge.		
		0xF	400 ms precharge.		

**ADC CHANNEL MUTES REGISTER**

Address: 0xC01C, Reset: 0x00, Name: ADC\_MUTES

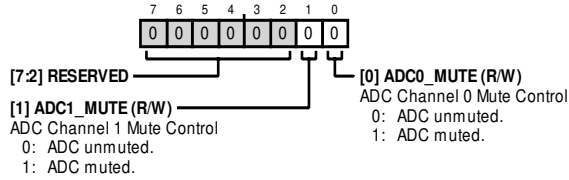

Table 66. Bit Descriptions for ADC\_MUTES

Bits	Bit Name	Settings	Description	Reset	Access
[7:2]	RESERVED		Reserved.	0x0	R
1	ADC1_MUTE	0 1	ADC Channel 1 Mute Control. 0: ADC unmuted. 1: ADC muted.	0x0	R/W
0	ADC0_MUTE	0 1	ADC Channel 0 Mute Control. 0: ADC unmuted. 1: ADC muted.	0x0	R/W

**ADC CHANNEL 0 VOLUME CONTROL REGISTER**

Address: 0xC01D, Reset: 0x40, Name: ADC0\_VOL

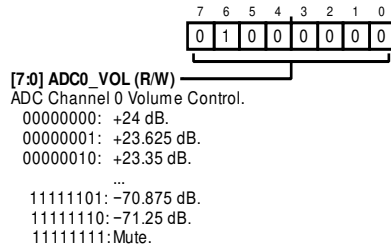
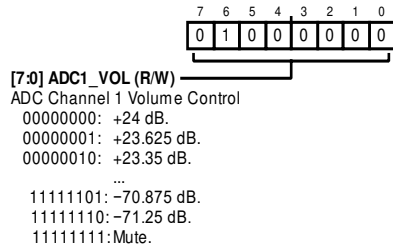

Table 67. Bit Descriptions for ADC0\_VOL

Bits	Bit Name	Settings	Description	Reset	Access
[7:0]	ADC0_VOL		ADC Channel 0 Volume Control.	0x40	R/W
		00000000	+24 dB.		
		00000001	+23.625 dB.		
		00000010	+23.35 dB.		
		00000011	+22.875 dB.		
		00000100	+22.5 dB.		
		...	...		
		00111111	+0.375 dB.		
		01000000	0 dB.		
		01000001	-0.375 dB.		
		...	...		
		11111101	-70.875 dB.		
		11111110	-71.25 dB.		
		11111111	Mute.		

**ADC CHANNEL 1 VOLUME CONTROL REGISTER**

Address: 0xC01E, Reset: 0x40, Name: ADC1\_VOL



**Table 68. Bit Descriptions for ADC1\_VOL**

Bits	Bit Name	Settings	Description	Reset	Access
[7:0]	ADC1_VOL		ADC Channel 1 Volume Control.	0x40	R/W
		00000000	+24 dB.		
		00000001	+23.625 dB.		
		00000010	+23.35 dB.		
		00000011	+22.875 dB.		
		00000100	+22.5 dB.		
		...	...		
		00111111	+0.375 dB.		
		01000000	0 dB.		
		01000001	-0.375 dB.		
		...	...		
		11111101	-70.875 dB.		
		11111110	-71.25 dB.		
		11111111	Mute.		

**PGA CHANNEL 0 GAIN CONTROL MSBs, MUTE, BOOST, AND SLEW REGISTER**

Address: 0xC021, Reset: 0x00, Name: PGA0\_CTRL1

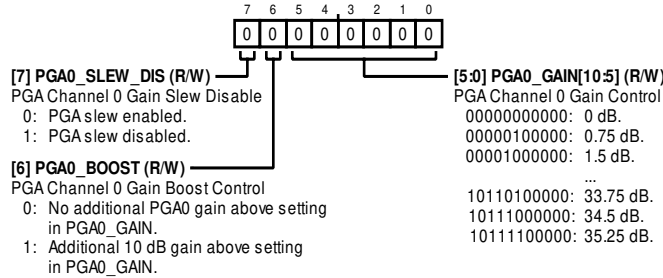

Table 69. Bit Descriptions for PGA0\_CTRL1

Bits	Bit Name	Settings	Description	Reset	Access
7	PGA0_SLEW_DIS	0 1	PGA Channel 0 Gain Slew Disable. PGA slew enabled. PGA slew disabled.	0x0	R/W
6	PGA0_BOOST	0 1	PGA Channel 0 Gain Boost Control. No additional PGA0 gain above setting in PGA0_GAIN. Additional 10 dB gain above setting in PGA0_GAIN.	0x0	R/W
[5:0]	PGA0_GAIN[10:5]	0000000000 0000010000 0000100000 ... 1011010000 1011100000 1011110000	PGA Channel 0 Gain Control. 0 dB. 0.75 dB. 1.5 dB. ... 33.75 dB. 34.5 dB. 35.25 dB.	0x0	R/W

**PGA CHANNEL 0 GAIN CONTROL LSBs REGISTER**

Address: 0xC022, Reset: 0x00, Name: PGA0\_CTRL2

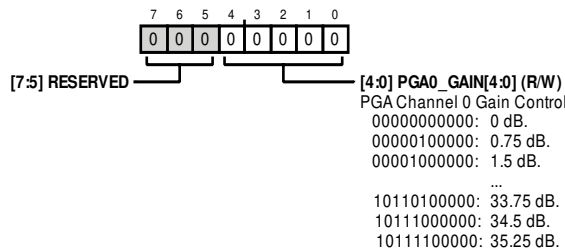

Table 70. Bit Descriptions for PGA0\_CTRL2

Bits	Bit Name	Settings	Description	Reset	Access
[7:5]	RESERVED		Reserved.	0x0	R
[4:0]	PGA0_GAIN[4:0]	0000000000 0000010000 0000100000 ... 1011010000 1011100000 1011110000	PGA Channel 0 Gain Control. 0 dB. 0.75 dB. 1.5 dB. ... 33.75 dB. 34.5 dB. 35.25 dB.	0x0	R/W

**PGA CHANNEL 1 GAIN CONTROL MSBs, MUTE, BOOST, AND SLEW REGISTER**

Address: 0xC023, Reset: 0x00, Name: PGA1\_CTRL1

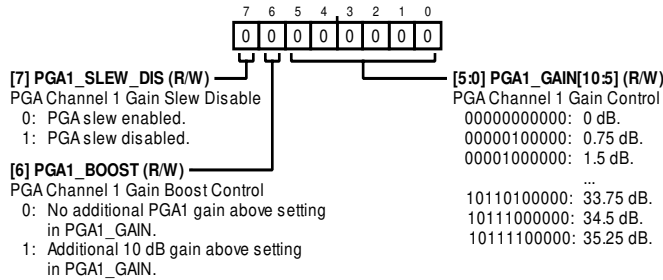

Table 71. Bit Descriptions for PGA1\_CTRL1

Bits	Bit Name	Settings	Description	Reset	Access
7	PGA1_SLEW_DIS		PGA Channel 1 Gain Slew Disable. 0: PGA slew enabled. 1: PGA slew disabled.	0x0	R/W
6	PGA1_BOOST		PGA Channel 1 Gain Boost Control. 0: No additional PGA1 gain above setting in PGA1_GAIN. 1: Additional 10 dB gain above setting in PGA1_GAIN.	0x0	R/W
[5:0]	PGA1_GAIN[10:5]		PGA Channel 1 Gain Control. 0000000000: 0 dB. 0000010000: 0.75 dB. 0000100000: 1.5 dB. ... 1011010000: 33.75 dB. 1011100000: 34.5 dB. 1011110000: 35.25 dB.	0x0	R/W

**PGA CHANNEL 1 GAIN CONTROL LSBs REGISTER**

Address: 0xC024, Reset: 0x00, Name: PGA1\_CTRL2

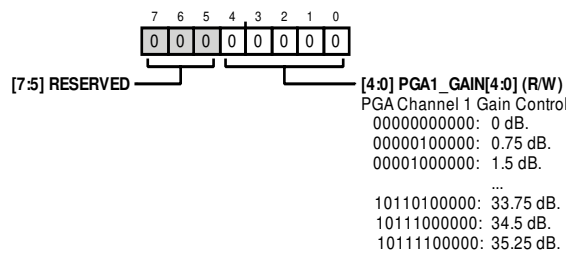

Table 72. Bit Descriptions for PGA1\_CTRL2

Bits	Bit Name	Settings	Description	Reset	Access
[7:5]	RESERVED		Reserved.	0x0	R
[4:0]	PGA1_GAIN[4:0]		PGA Channel 1 Gain Control. 0000000000: 0 dB. 0000010000: 0.75 dB. 0000100000: 1.5 dB. ... 1011010000: 33.75 dB. 1011100000: 34.5 dB. 1011110000: 35.25 dB.	0x0	R/W

**PGA SLEW RATE AND GAIN LINK REGISTER**

Address: 0xC029, Reset: 0x00, Name: PGA\_CTRL

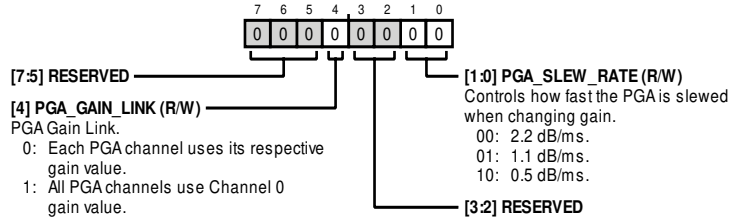

Table 73. Bit Descriptions for PGA\_CTRL

Bits	Bit Name	Settings	Description	Reset	Access
[7:5]	RESERVED		Reserved.	0x0	R
4	PGA_GAIN_LINK	0 1	PGA Gain Link. Each PGA channel uses its respective gain value. All PGA channels use Channel 0 gain value.	0x0	R/W
[3:2]	RESERVED		Reserved.	0x0	R
[1:0]	PGA_SLEW_RATE	00 01 10	Controls how fast the PGA is slewed when changing gain. 2.2 dB/ms. 1.1 dB/ms. 0.5 dB/ms.	0x0	R/W

**MICROPHONE BIAS LEVEL AND CURRENT REGISTER**

Address: 0xC02A, Reset: 0x00, Name: MBIAS\_CTRL

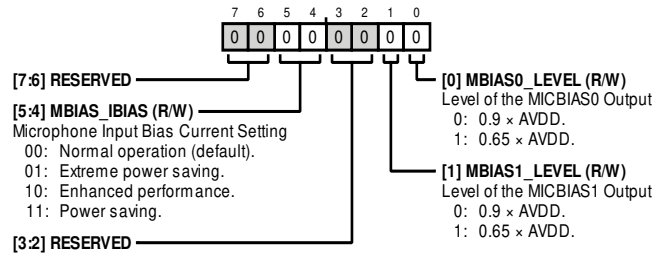
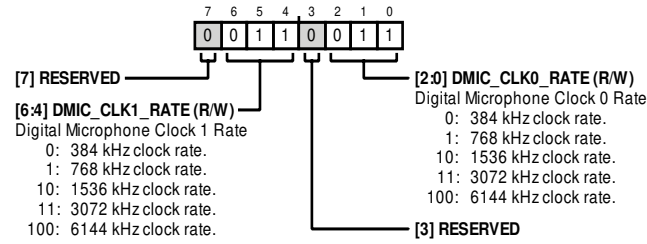

Table 74. Bit Descriptions for MBIAS\_CTRL

Bits	Bit Name	Settings	Description	Reset	Access
[7:6]	RESERVED		Reserved.	0x0	R
[5:4]	MBIAS_IBIAS	00 01 10 11	Microphone Input Bias Current Setting. Higher bias currents result in higher performance. Normal Operation (Default). Extreme power saving. Enhanced performance. Power saving.	0x0	R/W
[3:2]	RESERVED		Reserved.	0x0	R
1	MBIAS1_LEVEL	0 1	Level of the MICBIAS1 Output. 0.9 × AVDD. 0.65 × AVDD.	0x0	R/W
0	MBIAS0_LEVEL	0 1	Level of the MICBIAS0 Output. 0.9 × AVDD. 0.65 × AVDD.	0x0	R/W

**DMIC CLOCK RATE CONTROL REGISTER**

Address: 0xC02B, Reset: 0x33, Name: DMIC\_CTRL1



**Table 75. Bit Descriptions for DMIC\_CTRL1**

Bits	Bit Name	Settings	Description	Reset	Access
7	RESERVED		Reserved.	0x0	R
[6:4]	DMIC_CLK1_RATE	0 1 10 11 100	Digital Microphone Clock 1 Rate. 384 kHz clock rate. 768 kHz clock rate. 1536 kHz clock rate. 3072 kHz clock rate. 6144 kHz clock rate.	0x3	R/W
3	RESERVED		Reserved.	0x0	R
[2:0]	DMIC_CLK0_RATE	0 1 10 11 100	Digital Microphone Clock 0 Rate. 384 kHz clock rate. 768 kHz clock rate. 1536 kHz clock rate. 3072 kHz clock rate. 6144 kHz clock rate.	0x3	R/W

**DIGITAL MICROPHONE CHANNEL 0 AND CHANNEL 1 RATE, ORDER, MAPPING, AND EDGE CONTROL REGISTER**

Address: 0xC02C, Reset: 0x01, Name: DMIC\_CTRL2

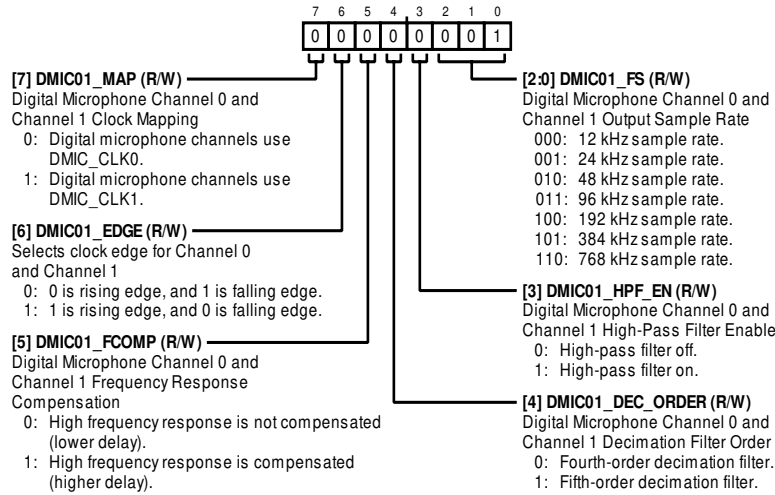

Table 76. Bit Descriptions for DMIC\_CTRL2

Bits	Bit Name	Settings	Description	Reset	Access
7	DMIC01_MAP	0 1	Digital Microphone Channel 0 and Channel 1 Clock Mapping. 0: Digital microphone channels use DMIC_CLK0. 1: Digital microphone channels use DMIC_CLK1.	0x0	R/W
6	DMIC01_EDGE	0 1	Selects clock edge for Channel 0 and Channel 1. 0: 0 is rising edge, and 1 is falling edge. 1: 1 is rising edge, and 0 is falling edge.	0x0	R/W
5	DMIC01_FCOMP	0 1	Digital Microphone Channel 0 and Channel 1 Frequency Response Compensation. 0: High frequency response is not compensated (lower delay). 1: High frequency response is compensated (higher delay).	0x0	R/W
4	DMIC01_DEC_ORDER	0 1	Digital Microphone Channel 0 and Channel 1 Decimation Filter Order. 0: Fourth-order decimation filter. 1: Fifth-order decimation filter.	0x0	R/W
3	DMIC01_HPF_EN	0 1	Digital Microphone Channel 0 and Channel 1 High-Pass Filter Enable. 0: High-pass filter off. 1: High-pass filter on.	0x0	R/W
[2:0]	DMIC01_FS	000 001 010 011 100 101 110	Digital Microphone Channel 0 and Channel 1 Output Sample Rate. 000: 12 kHz sample rate. 001: 24 kHz sample rate. 010: 48 kHz sample rate. 011: 96 kHz sample rate. 100: 192 kHz sample rate. 101: 384 kHz sample rate. 110: 768 kHz sample rate.	0x1	R/W



### DIGITAL MICROPHONE CHANNEL 2 AND CHANNEL 3 RATE, ORDER, MAPPING, AND EDGE CONTROL REGISTER

Address: 0xC02D, Reset: 0x01, Name: DMIC\_CTRL3

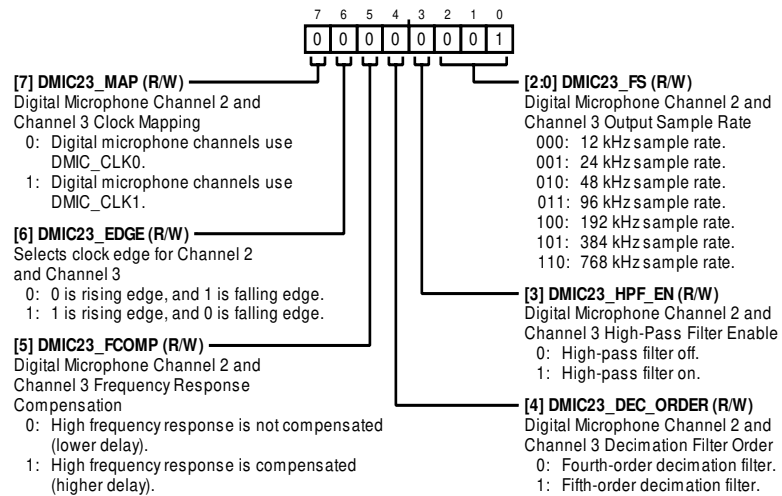

Table 77. Bit Descriptions for DMIC\_CTRL3

Bits	Bit Name	Settings	Description	Reset	Access
7	DMIC23_MAP	0 1	Digital Microphone Channel 2 and Channel 3 Clock Mapping. 0 Digital microphone channels use DMIC_CLK0. 1 Digital microphone channels use DMIC_CLK1.	0x0	R/W
6	DMIC23_EDGE	0 1	Selects clock edge for Channel 2 and Channel 3. 0 0 is rising edge, and 1 is falling edge. 1 1 is rising edge, and 0 is falling edge.	0x0	R/W
5	DMIC23_FCOMP	0 1	Digital Microphone Channel 2 and Channel 3 Frequency Response Compensation. 0 High frequency response is not compensated (lower delay). 1 High frequency response is compensated (higher delay).	0x0	R/W
4	DMIC23_DEC_ORDER	0 1	Digital Microphone Channel 2 and Channel 3 Decimation Filter Order. 0 Fourth-order decimation filter. 1 Fifth-order decimation filter.	0x0	R/W
3	DMIC23_HPF_EN	0 1	Digital Microphone Channel 2 and Channel 3 High-Pass Filter Enable. 0 High-pass filter off. 1 High-pass filter on.	0x0	R/W
[2:0]	DMIC23_FS	000 001 010 011 100 101 110	Digital Microphone Channel 2 and Channel 3 Output Sample Rate. 000 12 kHz sample rate. 001 24 kHz sample rate. 010 48 kHz sample rate. 011 96 kHz sample rate. 100 192 kHz sample rate. 101 384 kHz sample rate. 110 768 kHz sample rate.	0x1	R/W

**DMIC VOLUME OPTIONS REGISTER**

Address: 0xC030, Reset: 0x04, Name: DMIC\_CTRL6

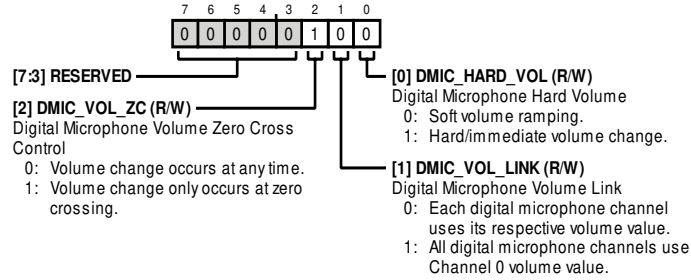

Table 78. Bit Descriptions for DMIC\_CTRL6

Bits	Bit Name	Settings	Description	Reset	Access
[7:3]	RESERVED		Reserved.	0x0	R
2	DMIC_VOL_ZC	0 1	Digital Microphone Volume Zero Cross Control. 0 Volume change occurs at any time. 1 Volume change only occurs at zero crossing.	0x1	R/W
1	DMIC_VOL_LINK	0 1	Digital Microphone Volume Link. 0 Each digital microphone channel uses its respective volume value. 1 All digital microphone channels use Channel 0 volume value.	0x0	R/W
0	DMIC_HARD_VOL	0 1	Digital Microphone Hard Volume. 0 Soft volume ramping. 1 Hard/immediate volume change.	0x0	R/W

**DIGITAL MICROPHONE CHANNEL MUTE CONTROLS REGISTER**

Address: 0xC031, Reset: 0x00, Name: DMIC\_MUTES

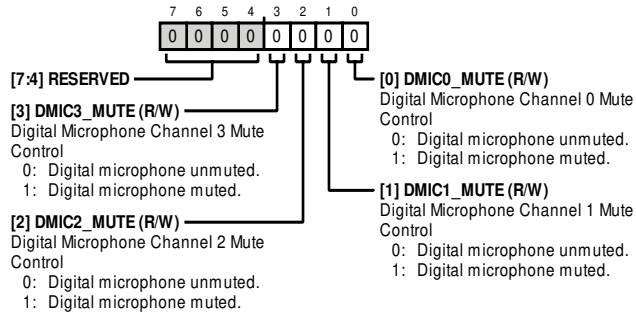

Table 79. Bit Descriptions for DMIC\_MUTES

Bits	Bit Name	Settings	Description	Reset	Access
[7:4]	RESERVED		Reserved.	0x0	R/W
3	DMIC3_MUTE	0 1	Digital Microphone Channel 3 Mute Control. 0 Digital microphone unmuted. 1 Digital microphone muted.	0x0	R/W
2	DMIC2_MUTE	0 1	Digital Microphone Channel 2 Mute Control. 0 Digital microphone unmuted. 1 Digital microphone muted.	0x0	R/W

Bits	Bit Name	Settings	Description	Reset	Access
1	DMIC1_MUTE	0 1	Digital Microphone Channel 1 Mute Control. Digital microphone unmuted. Digital microphone muted.	0x0	R/W
0	DMIC0_MUTE	0 1	Digital Microphone Channel 0 Mute Control. Digital microphone unmuted. Digital microphone muted.	0x0	R/W

**DIGITAL MICROPHONE CHANNEL 0 VOLUME CONTROL REGISTER**

Address: 0xC032, Reset: 0x40, Name: DMIC\_VOL0

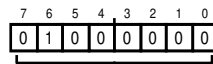

[7:0] DMIC0\_VOL (R/W)  
Digital Microphone Channel 0 Volume Control  
00000000: +24 dB.  
00000001: +23.625 dB.  
00000010: +23.35 dB.  
...  
11111101: -70.875 dB.  
11111110: -71.25 dB.  
11111111: Mute.

Table 80. Bit Descriptions for DMIC\_VOL0

Bits	Bit Name	Settings	Description	Reset	Access
[7:0]	DMIC0_VOL	00000000 00000001 00000010 00000011 00001000 ... 00111111 01000000 01000001 ... 11111101 11111110 11111111	Digital Microphone Channel 0 Volume Control. +24 dB. +23.625 dB. +23.35 dB. +22.875 dB. +22.5 dB. ... +0.375 dB. 0 dB. -0.375 dB. ... -70.875 dB. -71.25 dB. Mute.	0x40	R/W

**DIGITAL MICROPHONE CHANNEL 1 VOLUME CONTROL REGISTER**

Address: 0xC033, Reset: 0x40, Name: DMIC\_VOL1

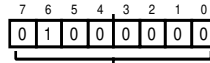

**[7:0] DMIC1\_VOL (R/W)**  
 Digital Microphone Channel 1 Volume Control  
 00000000: +24 dB.  
 00000001: +23.625 dB.  
 00000010: +23.35 dB.  
 ...  
 11111101: -70.875 dB.  
 11111110: -71.25 dB.  
 11111111: Mute.

**Table 81. Bit Descriptions for DMIC\_VOL1**

Bits	Bit Name	Settings	Description	Reset	Access
[7:0]	DMIC1_VOL		Digital Microphone Channel 1 Volume Control.	0x40	R/W
		00000000	+24 dB.		
		00000001	+23.625 dB.		
		00000010	+23.35 dB.		
		00000011	+22.875 dB.		
		00000100	+22.5 dB.		
		...	...		
		00111111	+0.375 dB.		
		01000000	0 dB.		
		01000001	-0.375 dB.		
		...	...		
		11111101	-70.875 dB.		
		11111110	-71.25 dB.		
		11111111	Mute.		

**DIGITAL MICROPHONE CHANNEL 2 VOLUME CONTROL REGISTER**

Address: 0xC034, Reset: 0x40, Name: DMIC\_VOL2

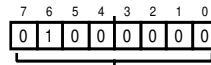

**[7:0] DMIC2\_VOL (R/W)**  
 Digital Microphone Channel 2 Volume Control  
 00000000: +24 dB.  
 00000001: +23.625 dB.  
 00000010: +23.35 dB.  
 ...  
 11111101: -70.875 dB.  
 11111110: -71.25 dB.  
 11111111: Mute.

Table 82. Bit Descriptions for DMIC\_VOL2

Bits	Bit Name	Settings	Description	Reset	Access
[7:0]	DMIC2_VOL		Digital Microphone Channel 2 Volume Control.	0x40	R/W
		00000000	+24 dB.		
		00000001	+23.625 dB.		
		00000010	+23.35 dB.		
		00000011	+22.875 dB.		
		00000100	+22.5 dB.		
		...	...		
		00111111	+0.375 dB.		
		01000000	0 dB.		
		01000001	-0.375 dB.		
		...	...		
		11111101	-70.875 dB.		
		11111110	-71.25 dB.		
		11111111	Mute.		

**DIGITAL MICROPHONE CHANNEL 3 VOLUME CONTROL REGISTER**

Address: 0xC035, Reset: 0x40, Name: DMIC\_VOL3

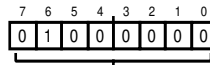

**[7:0] DMIC3\_VOL (R/W)**  
 Digital Microphone Channel 3 Volume Control  
 00000000: +24 dB.  
 00000001: +23.625 dB.  
 00000010: +23.35 dB.  
 ...  
 11111101: -70.875 dB.  
 11111110: -71.25 dB.  
 11111111: Mute.

**Table 83. Bit Descriptions for DMIC\_VOL3**

Bits	Bit Name	Settings	Description	Reset	Access
[7:0]	DMIC3_VOL		Digital Microphone Channel 3 Volume Control.	0x40	R/W
		00000000	+24 dB.		
		00000001	+23.625 dB.		
		00000010	+23.35 dB.		
		00000011	+22.875 dB.		
		00000100	+22.5 dB.		
		...	...		
		00111111	+0.375 dB.		
		01000000	0 dB.		
		01000001	-0.375 dB.		
		...	...		
		11111101	-70.875 dB.		
		11111110	-71.25 dB.		
		11111111	Mute.		

**DAC SAMPLE RATE, FILTERING, AND POWER CONTROLS REGISTER**

Address: 0xC03A, Reset: 0x02, Name: DAC\_CTRL1

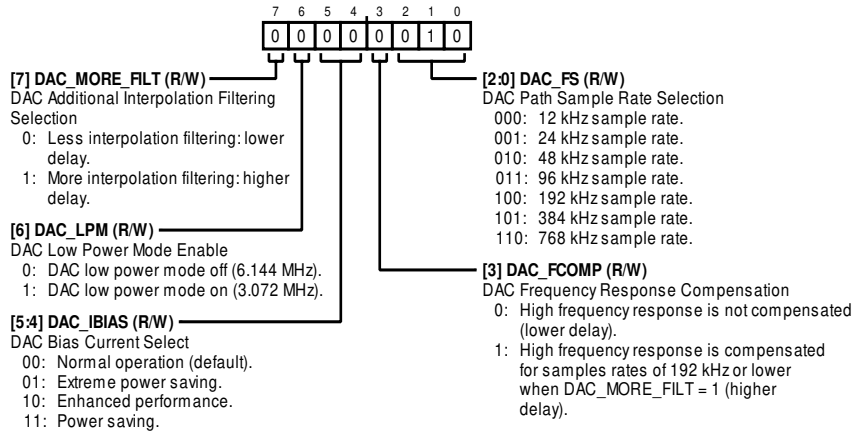

**Table 84. Bit Descriptions for DAC\_CTRL1**

Bits	Bit Name	Settings	Description	Reset	Access
7	DAC_MORE_FILT	0 1	DAC Additional Interpolation Filtering Selection. Less Interpolation Filtering: Lower Delay. More Interpolation Filtering: Higher Delay.	0x0	R/W
6	DAC_LPM	0 1	DAC Low Power Mode Enable. DAC low power mode off (6.144 MHz). DAC low power mode on (3.072 MHz).	0x0	R/W
[5:4]	DAC_IBIAS	00 01 10 11	DAC Bias Current Select. Higher bias currents result in higher performance. Normal operation (default). Extreme power saving. Enhanced performance. Power saving.	0x0	R/W
3	DAC_FCOMP	0 1	DAC Frequency Response Compensation. High frequency response is not compensated (lower delay). High frequency response is compensated for samples rates of 192 kHz or lower when DAC_MORE_FILT = 1 (higher delay).	0x0	R/W
[2:0]	DAC_FS	000 001 010 011 100 101 110	DAC Path Sample Rate Selection. 12 kHz sample rate. 24 kHz sample rate. 48 kHz sample rate. 96 kHz sample rate. 192 kHz sample rate. 384 kHz sample rate. 768 kHz sample rate.	0x2	R/W

**DAC VOLUME LUNK, HIGH-PASS FILTER, AND MUTE CONTROLS REGISTER**

Address: 0xC03B, Reset: 0xC4, Name: DAC\_CTRL2

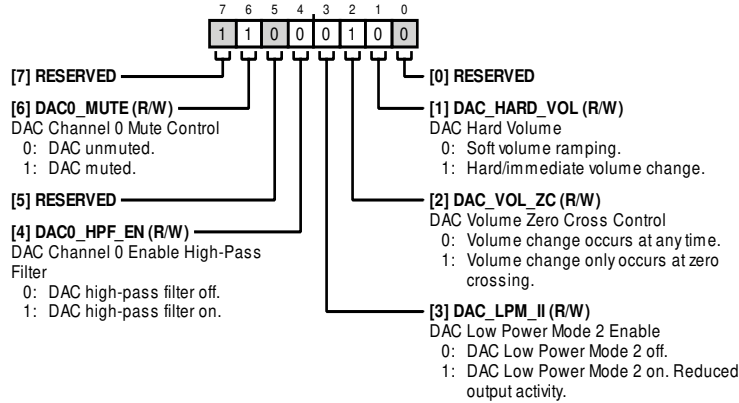

Table 85. Bit Descriptions for DAC\_CTRL2

Bits	Bit Name	Settings	Description	Reset	Access
7	RESERVED		Reserved.	0x1	R/W
6	DAC0_MUTE	0 1	DAC Channel 0 Mute Control. 0 DAC unmuted. 1 DAC muted.	0x1	R/W
5	RESERVED		Reserved.	0x0	R/W
4	DAC0_HPF_EN	0 1	DAC Channel 0 Enable High-Pass Filter. 0 DAC high-pass filter off. 1 DAC high-pass filter on.	0x0	R/W
3	DAC_LPM_II	0 1	DAC Low Power Mode 2 Enable. 0 DAC Low Power Mode 2 off. 1 DAC Low Power Mode 2 on. Reduced output activity.	0x0	R/W
2	DAC_VOL_ZC	0 1	DAC Volume Zero Cross Control. 0 Volume change occurs at any time. 1 Volume change only occurs at zero crossing.	0x1	R/W
1	DAC_HARD_VOL	0 1	DAC Hard Volume. 0 Soft volume ramping. 1 Hard/immediate volume change.	0x0	R/W
0	RESERVED		Reserved.	0x0	R/W



**DAC CHANNEL 0 VOLUME REGISTER**

Address: 0xC03C, Reset: 0x40, Name: DAC\_VOL0

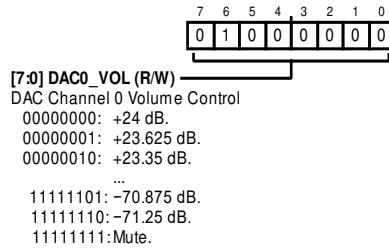
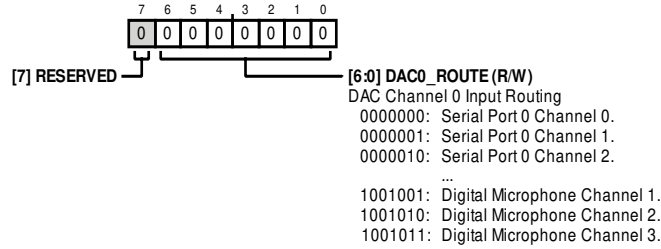

Table 86. Bit Descriptions for DAC\_VOL0

Bits	Bit Name	Settings	Description	Reset	Access
[7:0]	DAC0_VOL		DAC Channel 0 Volume Control.	0x40	R/W
		00000000	+24 dB.		
		00000001	+23.625 dB.		
		00000010	+23.35 dB.		
		00000011	+22.875 dB.		
		00000100	+22.5 dB.		
		...	...		
		00111111	+0.375 dB.		
		01000000	0 dB.		
		01000001	-0.375 dB.		
		...	...		
		11111101	-70.875 dB.		
		11111110	-71.25 dB.		
		11111111	Mute.		

**DAC CHANNEL 0 ROUTING REGISTER**

Address: 0xC03E, Reset: 0x00, Name: DAC\_ROUTE0



**Table 87. Bit Descriptions for DAC\_ROUTE0**

Bits	Bit Name	Settings	Description	Reset	Access
7	RESERVED		Reserved.	0x0	R
[6:0]	DAC0_ROUTE		DAC Channel 0 Input Routing.	0x0	R/W
		0000000	Serial Port 0 Channel 0.		
		0000001	Serial Port 0 Channel 1.		
		0000010	Serial Port 0 Channel 2.		
		0000011	Serial Port 0 Channel 3.		
		0000100	Serial Port 0 Channel 4.		
		0000101	Serial Port 0 Channel 5.		
		0000110	Serial Port 0 Channel 6.		
		0000111	Serial Port 0 Channel 7.		
		0001000	Serial Port 0 Channel 8.		
		0001001	Serial Port 0 Channel 9.		
		0001010	Serial Port 0 Channel 10.		
		0001011	Serial Port 0 Channel 11.		
		0001100	Serial Port 0 Channel 12.		
		0001101	Serial Port 0 Channel 13.		
		0001110	Serial Port 0 Channel 14.		
		0001111	Serial Port 0 Channel 15.		
		0100000	FastDSP Channel 0.		
		0100001	FastDSP Channel 1.		
		0100010	FastDSP Channel 2.		
		0100011	FastDSP Channel 3.		
		0100100	FastDSP Channel 4.		
		0100101	FastDSP Channel 5.		
		0100110	FastDSP Channel 6.		
		0100111	FastDSP Channel 7.		
		0101000	FastDSP Channel 8.		
		0101001	FastDSP Channel 9.		
		0101010	FastDSP Channel 10.		
		0101011	FastDSP Channel 11.		
		0101100	FastDSP Channel 12.		
		0101101	FastDSP Channel 13.		
		0101110	FastDSP Channel 14.		
		0101111	FastDSP Channel 15.		
		0110000	SigmaDSP Channel 0.		
		0110001	SigmaDSP Channel 1.		
		0110010	SigmaDSP Channel 2.		
		0110011	SigmaDSP Channel 3.		
		0110100	SigmaDSP Channel 4.		

Bits	Bit Name	Settings	Description	Reset	Access
		0110101	SigmaDSP Channel 5.		
		0110110	SigmaDSP Channel 6.		
		0110111	SigmaDSP Channel 7.		
		0111000	SigmaDSP Channel 8.		
		0111001	SigmaDSP Channel 9.		
		0111010	SigmaDSP Channel 10.		
		0111011	SigmaDSP Channel 11.		
		0111100	SigmaDSP Channel 12.		
		0111101	SigmaDSP Channel 13.		
		0111110	SigmaDSP Channel 14.		
		0111111	SigmaDSP Channel 15.		
		1000000	Input ASRC Channel 0.		
		1000001	Input ASRC Channel 1.		
		1000010	Input ASRC Channel 2.		
		1000011	Input ASRC Channel 3.		
		1000100	ADC Channel 0.		
		1000101	ADC Channel 1.		
		1001000	Digital Microphone Channel 0.		
		1001001	Digital Microphone Channel 1.		
		1001010	Digital Microphone Channel 2.		
		1001011	Digital Microphone Channel 3.		

### HEADPHONE CONTROL REGISTER

Address: 0xC040, Reset: 0x00, Name: HP\_CTRL

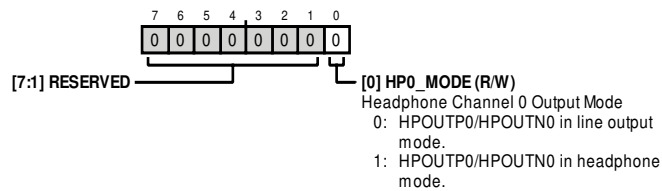
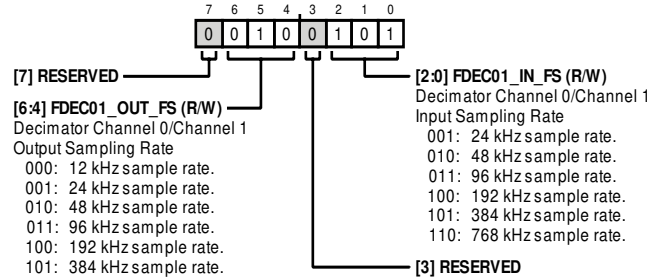

Table 88. Bit Descriptions for HP\_CTRL

Bits	Bit Name	Settings	Description	Reset	Access
[7:1]	RESERVED		Reserved.	0x0	R
0	HPO_MODE	0 1	Headphone Channel 0 Output Mode. HPOUTP0/HPOUTN0 in line output mode. HPOUTP0/HPOUTN0 in headphone mode.	0x0	R/W

**FAST TO SLOW DECIMATOR SAMPLE RATES CHANNEL 0 AND CHANNEL 1 REGISTER**

Address: 0xC041, Reset: 0x25, Name: FDEC\_CTRL1

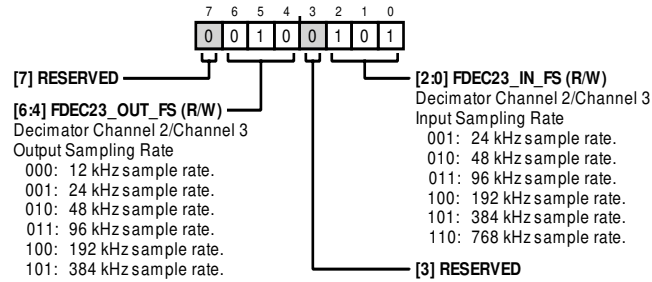

**Table 89. Bit Descriptions for FDEC\_CTRL1**

Bits	Bit Name	Settings	Description	Reset	Access
7	RESERVED		Reserved.	0x0	R
[6:4]	FDEC01_OUT_FS	000 001 010 011 100 101	Decimator Channel 0/Channel 1 Output Sampling Rate. 12 kHz sample rate. 24 kHz sample rate. 48 kHz sample rate. 96 kHz sample rate. 192 kHz sample rate. 384 kHz sample rate.	0x2	R/W
3	RESERVED		Reserved.	0x0	R
[2:0]	FDEC01_IN_FS	001 010 011 100 101 110	Decimator Channel 0/Channel 1 Input Sampling Rate. 24 kHz sample rate. 48 kHz sample rate. 96 kHz sample rate. 192 kHz sample rate. 384 kHz sample rate. 768 kHz sample rate.	0x5	R/W

**FAST TO SLOW DECIMATOR SAMPLE RATES CHANNEL 2 AND CHANNEL 3 REGISTER**

Address: 0xC042, Reset: 0x25, Name: FDEC\_CTRL2

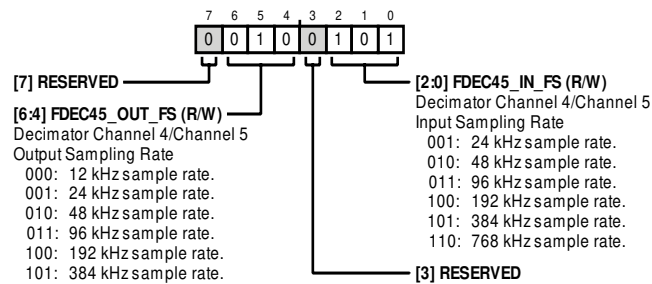

**Table 90. Bit Descriptions for FDEC\_CTRL2**

Bits	Bit Name	Settings	Description	Reset	Access
7	RESERVED		Reserved.	0x0	R
[6:4]	FDEC23_OUT_FS	000 001 010 011 100 101	Decimator Channel 2/Channel 3 Output Sampling Rate. 12 kHz sample rate. 24 kHz sample rate. 48 kHz sample rate. 96 kHz sample rate. 192 kHz sample rate. 384 kHz sample rate.	0x2	R/W
3	RESERVED		Reserved.	0x0	R
[2:0]	FDEC23_IN_FS	001 010 011 100 101 110	Decimator Channel 2/Channel 3 Input Sampling Rate. 24 kHz sample rate. 48 kHz sample rate. 96 kHz sample rate. 192 kHz sample rate. 384 kHz sample rate. 768 kHz sample rate.	0x5	R/W

**FAST TO SLOW DECIMATOR SAMPLE RATES CHANNEL 4 AND CHANNEL 5 REGISTER**

Address: 0xC043, Reset: 0x25, Name: FDEC\_CTRL3



**Table 91. Bit Descriptions for FDEC\_CTRL3**

Bits	Bit Name	Settings	Description	Reset	Access
7	RESERVED		Reserved.	0x0	R
[6:4]	FDEC45_OUT_FS	000 001 010 011 100 101	Decimator Channel 4/Channel 5 Output Sampling Rate. 12 kHz sample rate. 24 kHz sample rate. 48 kHz sample rate. 96 kHz sample rate. 192 kHz sample rate. 384 kHz sample rate.	0x2	R/W

Bits	Bit Name	Settings	Description	Reset	Access
3	RESERVED		Reserved.	0x0	R
[2:0]	FDEC45_IN_FS	001 010 011 100 101 110	Decimator Channel 4/Channel 5 Input Sampling Rate. 24 kHz sample rate. 48 kHz sample rate. 96 kHz sample rate. 192 kHz sample rate. 384 kHz sample rate. 768 kHz sample rate.	0x5	R/W

**FAST TO SLOW DECIMATOR SAMPLE RATES CHANNEL 6 AND CHANNEL 7 REGISTER**

Address: 0xC044, Reset: 0x25, Name: FDEC\_CTRL4

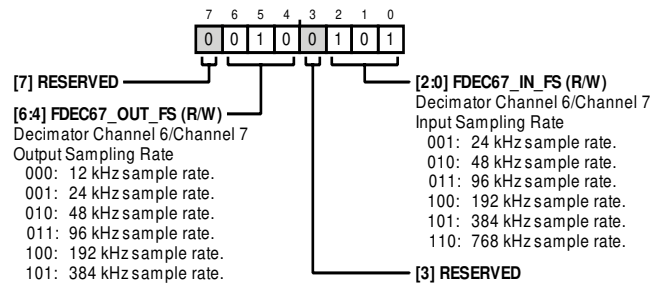
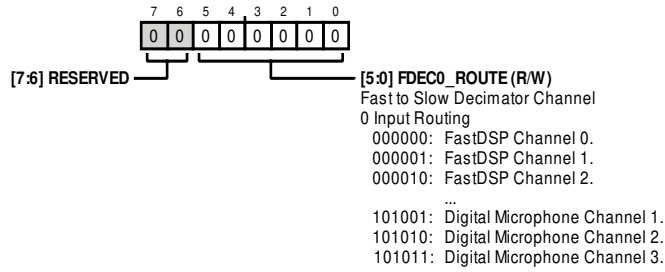

Table 92. Bit Descriptions for FDEC\_CTRL4

Bits	Bit Name	Settings	Description	Reset	Access
7	RESERVED		Reserved.	0x0	R
[6:4]	FDEC67_OUT_FS	000 001 010 011 100 101	Decimator Channel 6/Channel 7 Output Sampling Rate. 12 kHz sample rate. 24 kHz sample rate. 48 kHz sample rate. 96 kHz sample rate. 192 kHz sample rate. 384 kHz sample rate.	0x2	R/W
3	RESERVED		Reserved.	0x0	R
[2:0]	FDEC67_IN_FS	001 010 011 100 101 110	Decimator Channel 6/Channel 7 Input Sampling Rate. 24 kHz sample rate. 48 kHz sample rate. 96 kHz sample rate. 192 kHz sample rate. 384 kHz sample rate. 768 kHz sample rate.	0x5	R/W

**FAST TO SLOW DECIMATOR CHANNEL 0 INPUT ROUTING REGISTER**

Address: 0xC045, Reset: 0x00, Name: FDEC\_ROUTE0



**Table 93. Bit Descriptions for FDEC\_ROUTE0**

Bits	Bit Name	Settings	Description	Reset	Access
[7:6]	RESERVED		Reserved.	0x0	R
[5:0]	FDEC0_ROUTE		Fast to Slow Decimator Channel 0 Input Routing.	0x0	R/W
		000000	FastDSP Channel 0.		
		000001	FastDSP Channel 1.		
		000010	FastDSP Channel 2.		
		000011	FastDSP Channel 3.		
		000100	FastDSP Channel 4.		
		000101	FastDSP Channel 5.		
		000110	FastDSP Channel 6.		
		000111	FastDSP Channel 7.		
		001000	FastDSP Channel 8.		
		001001	FastDSP Channel 9.		
		001010	FastDSP Channel 10.		
		001011	FastDSP Channel 11.		
		001100	FastDSP Channel 12.		
		001101	FastDSP Channel 13.		
		001110	FastDSP Channel 14.		
		001111	FastDSP Channel 15.		
		010000	SigmaDSP Channel 0.		
		010001	SigmaDSP Channel 1.		
		010010	SigmaDSP Channel 2.		
		010011	SigmaDSP Channel 3.		
		010100	SigmaDSP Channel 4.		
		010101	SigmaDSP Channel 5.		
		010110	SigmaDSP Channel 6.		
		010111	SigmaDSP Channel 7.		
		011000	SigmaDSP Channel 8.		
		011001	SigmaDSP Channel 9.		
		011010	SigmaDSP Channel 10.		
		011011	SigmaDSP Channel 11.		
		011100	SigmaDSP Channel 12.		
		011101	SigmaDSP Channel 13.		
		011110	SigmaDSP Channel 14.		
		011111	SigmaDSP Channel 15.		
		100000	Input ASRC Channel 0.		
		100001	Input ASRC Channel 1.		
		100010	Input ASRC Channel 2.		
		100011	Input ASRC Channel 3.		

Bits	Bit Name	Settings	Description	Reset	Access
		100100	ADC Channel 0.		
		100101	ADC Channel 1.		
		101000	Digital Microphone Channel 0.		
		101001	Digital Microphone Channel 1.		
		101010	Digital Microphone Channel 2.		
		101011	Digital Microphone Channel 3.		

**FAST TO SLOW DECIMATOR CHANNEL 1 INPUT ROUTING REGISTER**

Address: 0xC046, Reset: 0x00, Name: FDEC\_ROUTE1

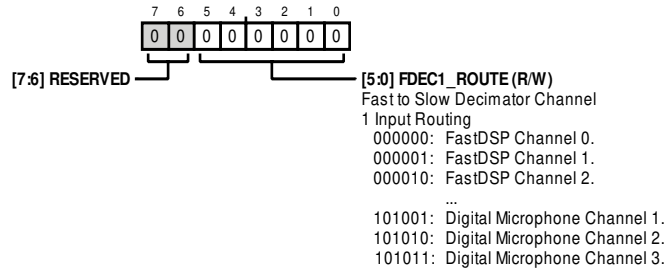

Table 94. Bit Descriptions for FDEC\_ROUTE1

Bits	Bit Name	Settings	Description	Reset	Access
[7:6]	RESERVED		Reserved.	0x0	R
[5:0]	FDEC1_ROUTE		Fast to Slow Decimator Channel 1 Input Routing.	0x0	R/W
		000000	FastDSP Channel 0.		
		000001	FastDSP Channel 1.		
		000010	FastDSP Channel 2.		
		000011	FastDSP Channel 3.		
		000100	FastDSP Channel 4.		
		000101	FastDSP Channel 5.		
		000110	FastDSP Channel 6.		
		000111	FastDSP Channel 7.		
		001000	FastDSP Channel 8.		
		001001	FastDSP Channel 9.		
		001010	FastDSP Channel 10.		
		001011	FastDSP Channel 11.		
		001100	FastDSP Channel 12.		
		001101	FastDSP Channel 13.		
		001110	FastDSP Channel 14.		
		001111	FastDSP Channel 15.		
		010000	SigmaDSP Channel 0.		
		010001	SigmaDSP Channel 1.		
		010010	SigmaDSP Channel 2.		
		010011	SigmaDSP Channel 3.		
		010100	SigmaDSP Channel 4.		
		010101	SigmaDSP Channel 5.		
		010110	SigmaDSP Channel 6.		
		010111	SigmaDSP Channel 7.		
		011000	SigmaDSP Channel 8.		
		011001	SigmaDSP Channel 9.		
		011010	SigmaDSP Channel 10.		



Bits	Bit Name	Settings	Description	Reset	Access
		011011	SigmaDSP Channel 11.		
		011100	SigmaDSP Channel 12.		
		011101	SigmaDSP Channel 13.		
		011110	SigmaDSP Channel 14.		
		011111	SigmaDSP Channel 15.		
		100000	Input ASRC Channel 0.		
		100001	Input ASRC Channel 1.		
		100010	Input ASRC Channel 2.		
		100011	Input ASRC Channel 3.		
		100100	ADC Channel 0.		
		100101	ADC Channel 1.		
		101000	Digital Microphone Channel 0.		
		101001	Digital Microphone Channel 1.		
		101010	Digital Microphone Channel 2.		
		101011	Digital Microphone Channel 3.		

**FAST TO SLOW DECIMATOR CHANNEL 2 INPUT ROUTING REGISTER**

Address: 0xC047, Reset: 0x00, Name: FDEC\_ROUTE2

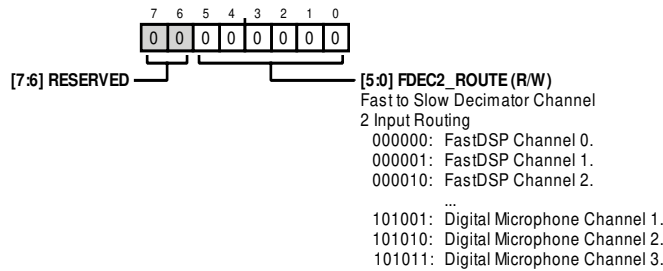

Table 95. Bit Descriptions for FDEC\_ROUTE2

Bits	Bit Name	Settings	Description	Reset	Access
[7:6]	RESERVED		Reserved.	0x0	R
[5:0]	FDEC2_ROUTE		Fast to Slow Decimator Channel 2 Input Routing.	0x0	R/W
		000000	FastDSP Channel 0.		
		000001	FastDSP Channel 1.		
		000010	FastDSP Channel 2.		
		000011	FastDSP Channel 3.		
		000100	FastDSP Channel 4.		
		000101	FastDSP Channel 5.		
		000110	FastDSP Channel 6.		
		000111	FastDSP Channel 7.		
		001000	FastDSP Channel 8.		
		001001	FastDSP Channel 9.		
		001010	FastDSP Channel 10.		
		001011	FastDSP Channel 11.		
		001100	FastDSP Channel 12.		
		001101	FastDSP Channel 13.		
		001110	FastDSP Channel 14.		
		001111	FastDSP Channel 15.		

Bits	Bit Name	Settings	Description	Reset	Access
		010000	SigmaDSP Channel 0.		
		010001	SigmaDSP Channel 1.		
		010010	SigmaDSP Channel 2.		
		010011	SigmaDSP Channel 3.		
		010100	SigmaDSP Channel 4.		
		010101	SigmaDSP Channel 5.		
		010110	SigmaDSP Channel 6.		
		010111	SigmaDSP Channel 7.		
		011000	SigmaDSP Channel 8.		
		011001	SigmaDSP Channel 9.		
		011010	SigmaDSP Channel 10.		
		011011	SigmaDSP Channel 11.		
		011100	SigmaDSP Channel 12.		
		011101	SigmaDSP Channel 13.		
		011110	SigmaDSP Channel 14.		
		011111	SigmaDSP Channel 15.		
		100000	Input ASRC Channel 0.		
		100001	Input ASRC Channel 1.		
		100010	Input ASRC Channel 2.		
		100011	Input ASRC Channel 3.		
		100100	ADC Channel 0.		
		100101	ADC Channel 1.		
		101000	Digital Microphone Channel 0.		
		101001	Digital Microphone Channel 1.		
		101010	Digital Microphone Channel 2.		
		101011	Digital Microphone Channel 3.		

**FAST TO SLOW DECIMATOR CHANNEL 3 INPUT ROUTING REGISTER**

Address: 0xC048, Reset: 0x00, Name: FDEC\_ROUTE3

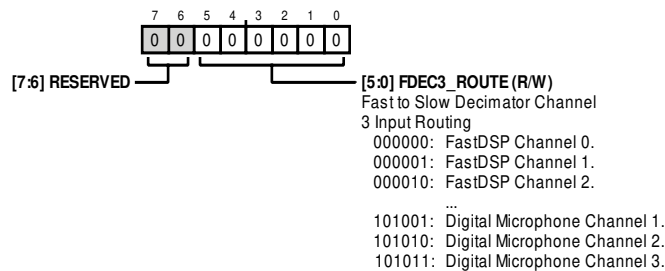

**Table 96. Bit Descriptions for FDEC\_ROUTE3**

Bits	Bit Name	Settings	Description	Reset	Access
[7:6]	RESERVED		Reserved.	0x0	R
[5:0]	FDEC3_ROUTE		Fast to Slow Decimator Channel 3 Input Routing.	0x0	R/W
		000000	FastDSP Channel 0.		
		000001	FastDSP Channel 1.		
		000010	FastDSP Channel 2.		
		000011	FastDSP Channel 3.		
		000100	FastDSP Channel 4.		

Bits	Bit Name	Settings	Description	Reset	Access
		000101	FastDSP Channel 5.		
		000110	FastDSP Channel 6.		
		000111	FastDSP Channel 7.		
		001000	FastDSP Channel 8.		
		001001	FastDSP Channel 9.		
		001010	FastDSP Channel 10.		
		001011	FastDSP Channel 11.		
		001100	FastDSP Channel 12.		
		001101	FastDSP Channel 13.		
		001110	FastDSP Channel 14.		
		001111	FastDSP Channel 15.		
		010000	SigmaDSP Channel 0.		
		010001	SigmaDSP Channel 1.		
		010010	SigmaDSP Channel 2.		
		010011	SigmaDSP Channel 3.		
		010100	SigmaDSP Channel 4.		
		010101	SigmaDSP Channel 5.		
		010110	SigmaDSP Channel 6.		
		010111	SigmaDSP Channel 7.		
		011000	SigmaDSP Channel 8.		
		011001	SigmaDSP Channel 9.		
		011010	SigmaDSP Channel 10.		
		011011	SigmaDSP Channel 11.		
		011100	SigmaDSP Channel 12.		
		011101	SigmaDSP Channel 13.		
		011110	SigmaDSP Channel 14.		
		011111	SigmaDSP Channel 15.		
		100000	Input ASRC Channel 0.		
		100001	Input ASRC Channel 1.		
		100010	Input ASRC Channel 2.		
		100011	Input ASRC Channel 3.		
		100100	ADC Channel 0.		
		100101	ADC Channel 1.		
		101000	Digital Microphone Channel 0.		
		101001	Digital Microphone Channel 1.		
		101010	Digital Microphone Channel 2.		
		101011	Digital Microphone Channel 3.		

**FAST TO SLOW DECIMATOR CHANNEL 4 INPUT ROUTING REGISTER**

Address: 0xC049, Reset: 0x00, Name: FDEC\_ROUTE4

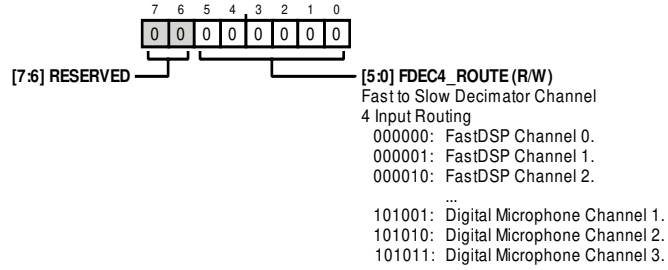

**Table 97. Bit Descriptions for FDEC\_ROUTE4**

Bits	Bit Name	Settings	Description	Reset	Access
[7:6]	RESERVED		Reserved.	0x0	R
[5:0]	FDEC4_ROUTE		Fast to Slow Decimator Channel 4 Input Routing.	0x0	R/W
		000000	FastDSP Channel 0.		
		000001	FastDSP Channel 1.		
		000010	FastDSP Channel 2.		
		000011	FastDSP Channel 3.		
		000100	FastDSP Channel 4.		
		000101	FastDSP Channel 5.		
		000110	FastDSP Channel 6.		
		000111	FastDSP Channel 7.		
		001000	FastDSP Channel 8.		
		001001	FastDSP Channel 9.		
		001010	FastDSP Channel 10.		
		001011	FastDSP Channel 11.		
		001100	FastDSP Channel 12.		
		001101	FastDSP Channel 13.		
		001110	FastDSP Channel 14.		
		001111	FastDSP Channel 15.		
		010000	SigmaDSP Channel 0.		
		010001	SigmaDSP Channel 1.		
		010010	SigmaDSP Channel 2.		
		010011	SigmaDSP Channel 3.		
		010100	SigmaDSP Channel 4.		
		010101	SigmaDSP Channel 5.		
		010110	SigmaDSP Channel 6.		
		010111	SigmaDSP Channel 7.		
		011000	SigmaDSP Channel 8.		
		011001	SigmaDSP Channel 9.		
		011010	SigmaDSP Channel 10.		
		011011	SigmaDSP Channel 11.		
		011100	SigmaDSP Channel 12.		
		011101	SigmaDSP Channel 13.		
		011110	SigmaDSP Channel 14.		
		011111	SigmaDSP Channel 15.		

Bits	Bit Name	Settings	Description	Reset	Access
		100000	Input ASRC Channel 0.		
		100001	Input ASRC Channel 1.		
		100010	Input ASRC Channel 2.		
		100011	Input ASRC Channel 3.		
		100100	ADC Channel 0.		
		100101	ADC Channel 1.		
		101000	Digital Microphone Channel 0.		
		101001	Digital Microphone Channel 1.		
		101010	Digital Microphone Channel 2.		
		101011	Digital Microphone Channel 3.		

**FAST TO SLOW DECIMATOR CHANNEL 5 INPUT ROUTING REGISTER**

Address: 0xC04A, Reset: 0x00, Name: FDEC\_ROUTE5

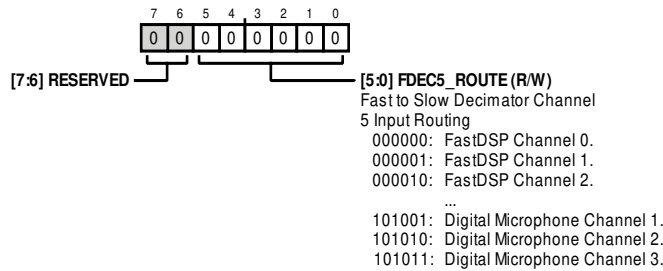

**Table 98. Bit Descriptions for FDEC\_ROUTE5**

Bits	Bit Name	Settings	Description	Reset	Access
[7:6]	RESERVED		Reserved.	0x0	R
[5:0]	FDEC5_ROUTE		Fast to Slow Decimator Channel 5 Input Routing.	0x0	R/W
		000000	FastDSP Channel 0.		
		000001	FastDSP Channel 1.		
		000010	FastDSP Channel 2.		
		000011	FastDSP Channel 3.		
		000100	FastDSP Channel 4.		
		000101	FastDSP Channel 5.		
		000110	FastDSP Channel 6.		
		000111	FastDSP Channel 7.		
		001000	FastDSP Channel 8.		
		001001	FastDSP Channel 9.		
		001010	FastDSP Channel 10.		
		001011	FastDSP Channel 11.		
		001100	FastDSP Channel 12.		
		001101	FastDSP Channel 13.		
		001110	FastDSP Channel 14.		
		001111	FastDSP Channel 15.		
		010000	SigmaDSP Channel 0.		
		010001	SigmaDSP Channel 1.		
		010010	SigmaDSP Channel 2.		
		010011	SigmaDSP Channel 3.		
		010100	SigmaDSP Channel 4.		
		010101	SigmaDSP Channel 5.		
		010110	SigmaDSP Channel 6.		

Bits	Bit Name	Settings	Description	Reset	Access
		010111	SigmaDSP Channel 7.		
		011000	SigmaDSP Channel 8.		
		011001	SigmaDSP Channel 9.		
		011010	SigmaDSP Channel 10.		
		011011	SigmaDSP Channel 11.		
		011100	SigmaDSP Channel 12.		
		011101	SigmaDSP Channel 13.		
		011110	SigmaDSP Channel 14.		
		011111	SigmaDSP Channel 15.		
		100000	Input ASRC Channel 0.		
		100001	Input ASRC Channel 1.		
		100010	Input ASRC Channel 2.		
		100011	Input ASRC Channel 3.		
		100100	ADC Channel 0.		
		100101	ADC Channel 1.		
		101000	Digital Microphone Channel 0.		
		101001	Digital Microphone Channel 1.		
		101010	Digital Microphone Channel 2.		
		101011	Digital Microphone Channel 3.		

**FAST TO SLOW DECIMATOR CHANNEL 6 INPUT ROUTING REGISTER**

Address: 0xC04B, Reset: 0x00, Name: FDEC\_ROUTE6

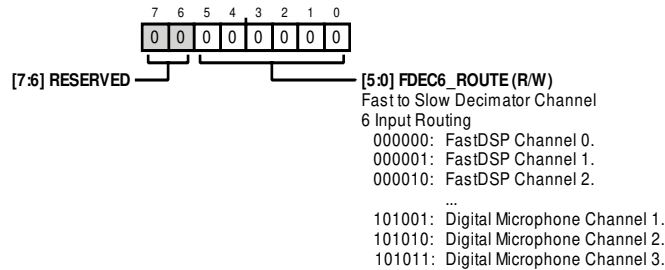

Table 99. Bit Descriptions for FDEC\_ROUTE6

Bits	Bit Name	Settings	Description	Reset	Access
[7:6]	RESERVED		Reserved.	0x0	R
[5:0]	FDEC6_ROUTE	000000 000001 000010 000011 000100 000101 000110 000111 001000 001001 001010 001011	Fast to Slow Decimator Channel 6 Input Routing. FastDSP Channel 0. FastDSP Channel 1. FastDSP Channel 2. FastDSP Channel 3. FastDSP Channel 4. FastDSP Channel 5. FastDSP Channel 6. FastDSP Channel 7. FastDSP Channel 8. FastDSP Channel 9. FastDSP Channel 10. FastDSP Channel 11.	0x0	R/W

Bits	Bit Name	Settings	Description	Reset	Access
		001100	FastDSP Channel 12.		
		001101	FastDSP Channel 13.		
		001110	FastDSP Channel 14.		
		001111	FastDSP Channel 15.		
		010000	SigmaDSP Channel 0.		
		010001	SigmaDSP Channel 1.		
		010010	SigmaDSP Channel 2.		
		010011	SigmaDSP Channel 3.		
		010100	SigmaDSP Channel 4.		
		010101	SigmaDSP Channel 5.		
		010110	SigmaDSP Channel 6.		
		010111	SigmaDSP Channel 7.		
		011000	SigmaDSP Channel 8.		
		011001	SigmaDSP Channel 9.		
		011010	SigmaDSP Channel 10.		
		011011	SigmaDSP Channel 11.		
		011100	SigmaDSP Channel 12.		
		011101	SigmaDSP Channel 13.		
		011110	SigmaDSP Channel 14.		
		011111	SigmaDSP Channel 15.		
		100000	Input ASRC Channel 0.		
		100001	Input ASRC Channel 1.		
		100010	Input ASRC Channel 2.		
		100011	Input ASRC Channel 3.		
		100100	ADC Channel 0.		
		100101	ADC Channel 1.		
		101000	Digital Microphone Channel 0.		
		101001	Digital Microphone Channel 1.		
		101010	Digital Microphone Channel 2.		
		101011	Digital Microphone Channel 3.		

**FAST TO SLOW DECIMATOR CHANNEL 7 INPUT ROUTING REGISTER**

Address: 0xC04C, Reset: 0x00, Name: FDEC\_ROUTE7

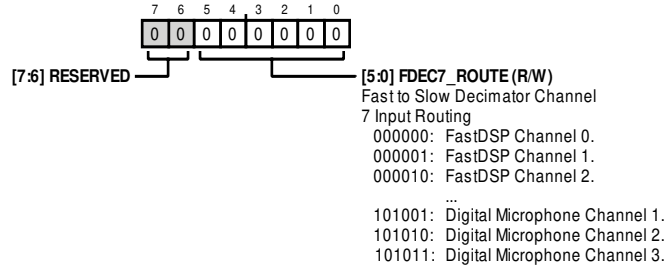

**Table 100. Bit Descriptions for FDEC\_ROUTE7**

Bits	Bit Name	Settings	Description	Reset	Access
[7:6]	RESERVED		Reserved.	0x0	R
[5:0]	FDEC7_ROUTE		Fast to Slow Decimator Channel 7 Input Routing.	0x0	R/W
		000000	FastDSP Channel 0.		
		000001	FastDSP Channel 1.		
		000010	FastDSP Channel 2.		
		000011	FastDSP Channel 3.		
		000100	FastDSP Channel 4.		
		000101	FastDSP Channel 5.		
		000110	FastDSP Channel 6.		
		000111	FastDSP Channel 7.		
		001000	FastDSP Channel 8.		
		001001	FastDSP Channel 9.		
		001010	FastDSP Channel 10.		
		001011	FastDSP Channel 11.		
		001100	FastDSP Channel 12.		
		001101	FastDSP Channel 13.		
		001110	FastDSP Channel 14.		
		001111	FastDSP Channel 15.		
		010000	SigmaDSP Channel 0.		
		010001	SigmaDSP Channel 1.		
		010010	SigmaDSP Channel 2.		
		010011	SigmaDSP Channel 3.		
		010100	SigmaDSP Channel 4.		
		010101	SigmaDSP Channel 5.		
		010110	SigmaDSP Channel 6.		
		010111	SigmaDSP Channel 7.		
		011000	SigmaDSP Channel 8.		
		011001	SigmaDSP Channel 9.		
		011010	SigmaDSP Channel 10.		
		011011	SigmaDSP Channel 11.		
		011100	SigmaDSP Channel 12.		
		011101	SigmaDSP Channel 13.		
		011110	SigmaDSP Channel 14.		
		011111	SigmaDSP Channel 15.		



Bits	Bit Name	Settings	Description	Reset	Access
		100000	Input ASRC Channel 0.		
		100001	Input ASRC Channel 1.		
		100010	Input ASRC Channel 2.		
		100011	Input ASRC Channel 3.		
		100100	ADC Channel 0.		
		100101	ADC Channel 1.		
		101000	Digital Microphone Channel 0.		
		101001	Digital Microphone Channel 1.		
		101010	Digital Microphone Channel 2.		
		101011	Digital Microphone Channel 3.		

**SLOW TO FAST INTERPOLATOR SAMPLE RATES CHANNEL 0/CHANNEL 1 REGISTER**

Address: 0xC04D, Reset: 0x52, Name: FINT\_CTRL1

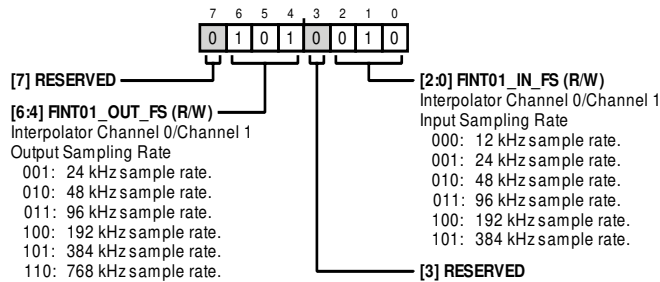
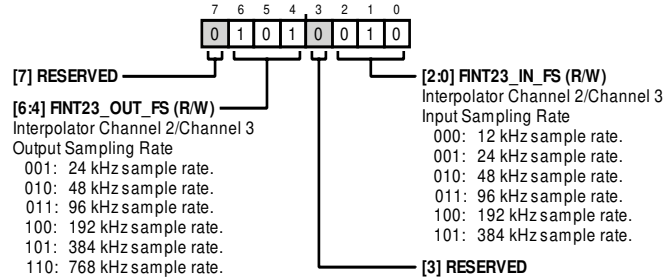

Table 101. Bit Descriptions for FINT\_CTRL1

Bits	Bit Name	Settings	Description	Reset	Access
7	RESERVED		Reserved.	0x0	R
[6:4]	FINT01_OUT_FS	001 24 kHz sample rate. 010 48 kHz sample rate. 011 96 kHz sample rate. 100 192 kHz sample rate. 101 384 kHz sample rate. 110 768 kHz sample rate.	Interpolator Channel 0/Channel 1 Output Sampling Rate.	0x5	R/W
3	RESERVED		Reserved.	0x0	R
[2:0]	FINT01_IN_FS	000 12 kHz sample rate. 001 24 kHz sample rate. 010 48 kHz sample rate. 011 96 kHz sample rate. 100 192 kHz sample rate. 101 384 kHz sample rate.	Interpolator Channel 0/Channel 1 Input Sampling Rate.	0x2	R/W

**SLOW TO FAST INTERPOLATOR SAMPLE RATES CHANNEL 2/CHANNEL 3 REGISTER**

Address: 0xC04E, Reset: 0x52, Name: FINT\_CTRL2

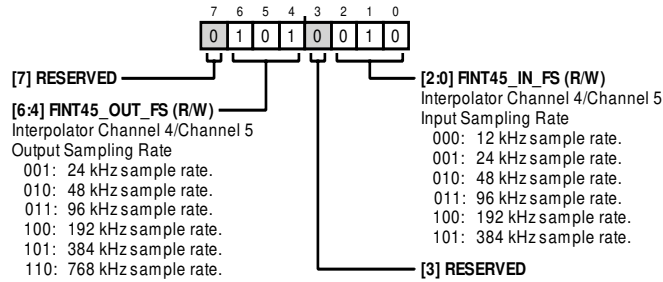

**Table 102. Bit Descriptions for FINT\_CTRL2**

Bits	Bit Name	Settings	Description	Reset	Access
7	RESERVED		Reserved.	0x0	R
[6:4]	FINT23_OUT_FS	001 010 011 100 101 110	Interpolator Channel 2/Channel 3 Output Sampling Rate. 24 kHz sample rate. 48 kHz sample rate. 96 kHz sample rate. 192 kHz sample rate. 384 kHz sample rate. 768 kHz sample rate.	0x5	R/W
3	RESERVED		Reserved.	0x0	R
[2:0]	FINT23_IN_FS	000 001 010 011 100 101	Interpolator Channel 2/Channel 3 Input Sampling Rate. 12 kHz sample rate. 24 kHz sample rate. 48 kHz sample rate. 96 kHz sample rate. 192 kHz sample rate. 384 kHz sample rate.	0x2	R/W

**SLOW TO FAST INTERPOLATOR SAMPLE RATES CHANNEL 4/CHANNEL 5 REGISTER**

Address: 0xC04F, Reset: 0x52, Name: FINT\_CTRL3

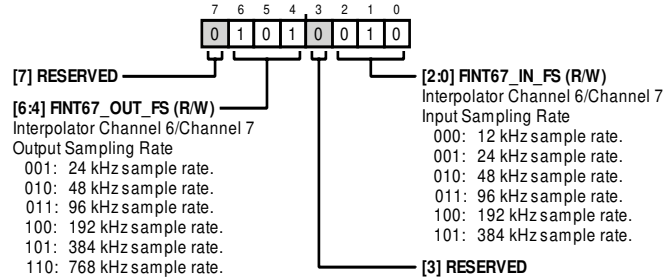

**Table 103. Bit Descriptions for FINT\_CTRL3**

Bits	Bit Name	Settings	Description	Reset	Access
7	RESERVED		Reserved.	0x0	R
[6:4]	FINT45_OUT_FS	001 010 011 100 101 110	Interpolator Channel 4/Channel 5 Output Sampling Rate. 24 kHz sample rate. 48 kHz sample rate. 96 kHz sample rate. 192 kHz sample rate. 384 kHz sample rate. 768 kHz sample rate.	0x5	R/W
3	RESERVED		Reserved.	0x0	R
[2:0]	FINT45_IN_FS	000 001 010 011 100 101	Interpolator Channel 4/Channel 5 Input Sampling Rate. 12 kHz sample rate. 24 kHz sample rate. 48 kHz sample rate. 96 kHz sample rate. 192 kHz sample rate. 384 kHz sample rate.	0x2	R/W

**SLOW TO FAST INTERPOLATOR SAMPLE RATES CHANNEL 6/CHANNEL 7 REGISTER**

Address: 0xC050, Reset: 0x52, Name: FINT\_CTRL4

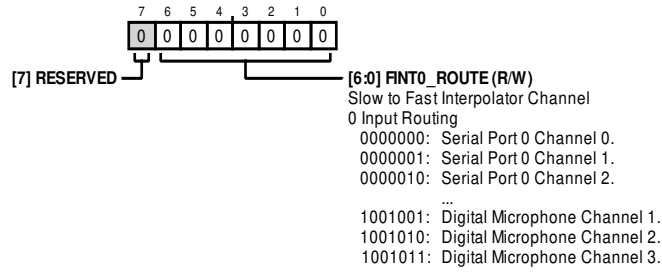

**Table 104. Bit Descriptions for FINT\_CTRL4**

Bits	Bit Name	Settings	Description	Reset	Access
7	RESERVED		Reserved.	0x0	R
[6:4]	FINT67_OUT_FS	001 010 011 100 101 110	Interpolator Channel 6/Channel 7 Output Sampling Rate. 24 kHz sample rate. 48 kHz sample rate. 96 kHz sample rate. 192 kHz sample rate. 384 kHz sample rate. 768 kHz sample rate.	0x5	R/W
3	RESERVED		Reserved.	0x0	R
[2:0]	FINT67_IN_FS	000 001 010 011 100 101	Interpolator Channel 6/Channel 7 Input Sampling Rate. 12 kHz sample rate. 24 kHz sample rate. 48 kHz sample rate. 96 kHz sample rate. 192 kHz sample rate. 384 kHz sample rate.	0x2	R/W

**SLOW TO FAST INTERPOLATOR CHANNEL 0 INPUT ROUTING REGISTER**

Address: 0xC051, Reset: 0x00, Name: FINT\_ROUTE0



**Table 105. Bit Descriptions for FINT\_ROUTE0**

Bits	Bit Name	Settings	Description	Reset	Access
7	RESERVED		Reserved.	0x0	R
[6:0]	FINT_ROUTE		Slow to Fast Interpolator Channel 0 Input Routing.	0x0	R/W
		0000000	Serial Port 0 Channel 0.		
		0000001	Serial Port 0 Channel 1.		
		0000010	Serial Port 0 Channel 2.		
		0000011	Serial Port 0 Channel 3.		
		0000100	Serial Port 0 Channel 4.		
		0000101	Serial Port 0 Channel 5.		
		0000110	Serial Port 0 Channel 6.		
		0000111	Serial Port 0 Channel 7.		
		0001000	Serial Port 0 Channel 8.		
		0001001	Serial Port 0 Channel 9.		
		0001010	Serial Port 0 Channel 10.		
		0001011	Serial Port 0 Channel 11.		
		0001100	Serial Port 0 Channel 12.		
		0001101	Serial Port 0 Channel 13.		
		0001110	Serial Port 0 Channel 14.		
		0001111	Serial Port 0 Channel 15.		
		0100000	FastDSP Channel 0.		
		0100001	FastDSP Channel 1.		
		0100010	FastDSP Channel 2.		
		0100011	FastDSP Channel 3.		
		0100100	FastDSP Channel 4.		
		0100101	FastDSP Channel 5.		
		0100110	FastDSP Channel 6.		
		0100111	FastDSP Channel 7.		
		0101000	FastDSP Channel 8.		
		0101001	FastDSP Channel 9.		
		0101010	FastDSP Channel 10.		
		0101011	FastDSP Channel 11.		
		0101100	FastDSP Channel 12.		
		0101101	FastDSP Channel 13.		
		0101110	FastDSP Channel 14.		
		0101111	FastDSP Channel 15.		

Bits	Bit Name	Settings	Description	Reset	Access
		0110000	SigmaDSP Channel 0.		
		0110001	SigmaDSP Channel 1.		
		0110010	SigmaDSP Channel 2.		
		0110011	SigmaDSP Channel 3.		
		0110100	SigmaDSP Channel 4.		
		0110101	SigmaDSP Channel 5.		
		0110110	SigmaDSP Channel 6.		
		0110111	SigmaDSP Channel 7.		
		0111000	SigmaDSP Channel 8.		
		0111001	SigmaDSP Channel 9.		
		0111010	SigmaDSP Channel 10.		
		0111011	SigmaDSP Channel 11.		
		0111100	SigmaDSP Channel 12.		
		0111101	SigmaDSP Channel 13.		
		0111110	SigmaDSP Channel 14.		
		0111111	SigmaDSP Channel 15.		
		1000000	Input ASRC Channel 0.		
		1000001	Input ASRC Channel 1.		
		1000010	Input ASRC Channel 2.		
		1000011	Input ASRC Channel 3.		
		1000100	ADC Channel 0.		
		1000101	ADC Channel 1.		
		1001000	Digital Microphone Channel 0.		
		1001001	Digital Microphone Channel 1.		
		1001010	Digital Microphone Channel 2.		
		1001011	Digital Microphone Channel 3.		

**SLOW TO FAST INTERPOLATOR CHANNEL 1 INPUT ROUTING REGISTER**

Address: 0xC052, Reset: 0x00, Name: FINT\_ROUTE1

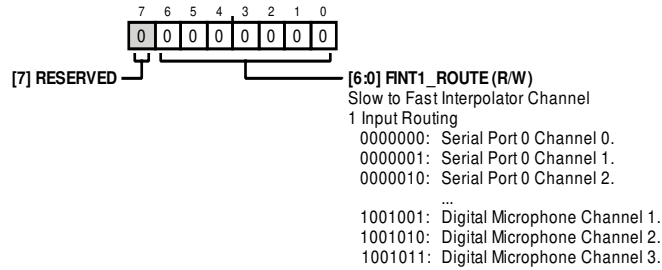

**Table 106. Bit Descriptions for FINT\_ROUTE1**

Bits	Bit Name	Settings	Description	Reset	Access
7	RESERVED		Reserved.	0x0	R
[6:0]	FINT1_ROUTE	0000000 0000001 0000010 0000011 0000100 0000101 0000110 0000111 0001000 0001001 0001010 0001011 0001100 0001101 0001110 0001111 0100000 0100001 0100010 0100011 0100100 0100101 0100110 0100111 0101000 0101001 0101010 0101011 0101100 0101101 0101110 0101111	Slow to Fast Interpolator Channel 1 Input Routing. Serial Port 0 Channel 0. Serial Port 0 Channel 1. Serial Port 0 Channel 2. Serial Port 0 Channel 3. Serial Port 0 Channel 4. Serial Port 0 Channel 5. Serial Port 0 Channel 6. Serial Port 0 Channel 7. Serial Port 0 Channel 8. Serial Port 0 Channel 9. Serial Port 0 Channel 10. Serial Port 0 Channel 11. Serial Port 0 Channel 12. Serial Port 0 Channel 13. Serial Port 0 Channel 14. Serial Port 0 Channel 15. FastDSP Channel 0. FastDSP Channel 1. FastDSP Channel 2. FastDSP Channel 3. FastDSP Channel 4. FastDSP Channel 5. FastDSP Channel 6. FastDSP Channel 7. FastDSP Channel 8. FastDSP Channel 9. FastDSP Channel 10. FastDSP Channel 11. FastDSP Channel 12. FastDSP Channel 13. FastDSP Channel 14. FastDSP Channel 15.	0x0	R/W

Bits	Bit Name	Settings	Description	Reset	Access
		0110000	SigmaDSP Channel 0.		
		0110001	SigmaDSP Channel 1.		
		0110010	SigmaDSP Channel 2.		
		0110011	SigmaDSP Channel 3.		
		0110100	SigmaDSP Channel 4.		
		0110101	SigmaDSP Channel 5.		
		0110110	SigmaDSP Channel 6.		
		0110111	SigmaDSP Channel 7.		
		0111000	SigmaDSP Channel 8.		
		0111001	SigmaDSP Channel 9.		
		0111010	SigmaDSP Channel 10.		
		0111011	SigmaDSP Channel 11.		
		0111100	SigmaDSP Channel 12.		
		0111101	SigmaDSP Channel 13.		
		0111110	SigmaDSP Channel 14.		
		0111111	SigmaDSP Channel 15.		
		1000000	Input ASRC Channel 0.		
		1000001	Input ASRC Channel 1.		
		1000010	Input ASRC Channel 2.		
		1000011	Input ASRC Channel 3.		
		1000100	ADC Channel 0.		
		1000101	ADC Channel 1.		
		1001000	Digital Microphone Channel 0.		
		1001001	Digital Microphone Channel 1.		
		1001010	Digital Microphone Channel 2.		
		1001011	Digital Microphone Channel 3.		

**SLOW TO FAST INTERPOLATOR CHANNEL 2 INPUT ROUTING REGISTER**

Address: 0xC053, Reset: 0x00, Name: FINT\_ROUTE2

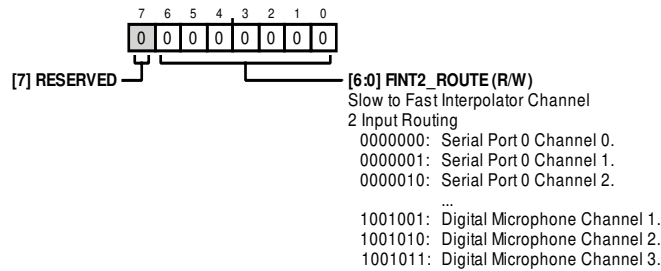

Table 107. Bit Descriptions for FINT\_ROUTE2

Bits	Bit Name	Settings	Description	Reset	Access
7	RESERVED		Reserved.	0x0	R
[6:0]	FINT2_ROUTE	0000000 0000001 0000010 0000011 0000100	Slow to Fast Interpolator Channel 2 Input Routing. Serial Port 0 Channel 0. Serial Port 0 Channel 1. Serial Port 0 Channel 2. Serial Port 0 Channel 3. Serial Port 0 Channel 4.	0x0	R/W



Bits	Bit Name	Settings	Description	Reset	Access
		0000101	Serial Port 0 Channel 5.		
		0000110	Serial Port 0 Channel 6.		
		0000111	Serial Port 0 Channel 7.		
		0001000	Serial Port 0 Channel 8.		
		0001001	Serial Port 0 Channel 9.		
		0001010	Serial Port 0 Channel 10.		
		0001011	Serial Port 0 Channel 11.		
		0001100	Serial Port 0 Channel 12.		
		0001101	Serial Port 0 Channel 13.		
		0001110	Serial Port 0 Channel 14.		
		0001111	Serial Port 0 Channel 15.		
		0100000	FastDSP Channel 0.		
		0100001	FastDSP Channel 1.		
		0100010	FastDSP Channel 2.		
		0100011	FastDSP Channel 3.		
		0100100	FastDSP Channel 4.		
		0100101	FastDSP Channel 5.		
		0100110	FastDSP Channel 6.		
		0100111	FastDSP Channel 7.		
		0101000	FastDSP Channel 8.		
		0101001	FastDSP Channel 9.		
		0101010	FastDSP Channel 10.		
		0101011	FastDSP Channel 11.		
		0101100	FastDSP Channel 12.		
		0101101	FastDSP Channel 13.		
		0101110	FastDSP Channel 14.		
		0101111	FastDSP Channel 15.		
		0110000	SigmaDSP Channel 0.		
		0110001	SigmaDSP Channel 1.		
		0110010	SigmaDSP Channel 2.		
		0110011	SigmaDSP Channel 3.		
		0110100	SigmaDSP Channel 4.		
		0110101	SigmaDSP Channel 5.		
		0110110	SigmaDSP Channel 6.		
		0110111	SigmaDSP Channel 7.		
		0111000	SigmaDSP Channel 8.		
		0111001	SigmaDSP Channel 9.		
		0111010	SigmaDSP Channel 10.		
		0111011	SigmaDSP Channel 11.		
		0111100	SigmaDSP Channel 12.		
		0111101	SigmaDSP Channel 13.		
		0111110	SigmaDSP Channel 14.		
		0111111	SigmaDSP Channel 15.		
		1000000	Input ASRC Channel 0.		
		1000001	Input ASRC Channel 1.		
		1000010	Input ASRC Channel 2.		
		1000011	Input ASRC Channel 3.		

Bits	Bit Name	Settings	Description	Reset	Access
		1000100	ADC Channel 0.		
		1000101	ADC Channel 1.		
		1001000	Digital Microphone Channel 0.		
		1001001	Digital Microphone Channel 1.		
		1001010	Digital Microphone Channel 2.		
		1001011	Digital Microphone Channel 3.		

**SLOW TO FAST INTERPOLATOR CHANNEL 3 INPUT ROUTING REGISTER**

Address: 0xC054, Reset: 0x00, Name: FINT\_ROUTE3

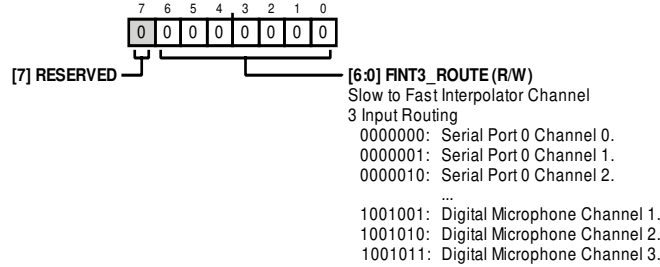

**Table 108. Bit Descriptions for FINT\_ROUTE3**

Bits	Bit Name	Settings	Description	Reset	Access
7	RESERVED		Reserved.	0x0	R
[6:0]	FINT3_ROUTE		Slow to Fast Interpolator Channel 3 Input Routing.	0x0	R/W
		0000000	Serial Port 0 Channel 0.		
		0000001	Serial Port 0 Channel 1.		
		0000010	Serial Port 0 Channel 2.		
		0000011	Serial Port 0 Channel 3.		
		0000100	Serial Port 0 Channel 4.		
		0000101	Serial Port 0 Channel 5.		
		0000110	Serial Port 0 Channel 6.		
		0000111	Serial Port 0 Channel 7.		
		0001000	Serial Port 0 Channel 8.		
		0001001	Serial Port 0 Channel 9.		
		0001010	Serial Port 0 Channel 10.		
		0001011	Serial Port 0 Channel 11.		
		0001100	Serial Port 0 Channel 12.		
		0001101	Serial Port 0 Channel 13.		
		0001110	Serial Port 0 Channel 14.		
		0001111	Serial Port 0 Channel 15.		
		0100000	FastDSP Channel 0.		
		0100001	FastDSP Channel 1.		
		0100010	FastDSP Channel 2.		
		0100011	FastDSP Channel 3.		
		0100100	FastDSP Channel 4.		
		0100101	FastDSP Channel 5.		
		0100110	FastDSP Channel 6.		

Bits	Bit Name	Settings	Description	Reset	Access
		0100111	FastDSP Channel 7.		
		0101000	FastDSP Channel 8.		
		0101001	FastDSP Channel 9.		
		0101010	FastDSP Channel 10.		
		0101011	FastDSP Channel 11.		
		0101100	FastDSP Channel 12.		
		0101101	FastDSP Channel 13.		
		0101110	FastDSP Channel 14.		
		0101111	FastDSP Channel 15.		
		0110000	SigmaDSP Channel 0.		
		0110001	SigmaDSP Channel 1.		
		0110010	SigmaDSP Channel 2.		
		0110011	SigmaDSP Channel 3.		
		0110100	SigmaDSP Channel 4.		
		0110101	SigmaDSP Channel 5.		
		0110110	SigmaDSP Channel 6.		
		0110111	SigmaDSP Channel 7.		
		0111000	SigmaDSP Channel 8.		
		0111001	SigmaDSP Channel 9.		
		0111010	SigmaDSP Channel 10.		
		0111011	SigmaDSP Channel 11.		
		0111100	SigmaDSP Channel 12.		
		0111101	SigmaDSP Channel 13.		
		0111110	SigmaDSP Channel 14.		
		0111111	SigmaDSP Channel 15.		
		1000000	Input ASRC Channel 0.		
		1000001	Input ASRC Channel 1.		
		1000010	Input ASRC Channel 2.		
		1000011	Input ASRC Channel 3.		
		1000100	ADC Channel 0.		
		1000101	ADC Channel 1.		
		1001000	Digital Microphone Channel 0.		
		1001001	Digital Microphone Channel 1.		
		1001010	Digital Microphone Channel 2.		
		1001011	Digital Microphone Channel 3.		

**SLOW TO FAST INTERPOLATOR CHANNEL 4 INPUT ROUTING REGISTER**

Address: 0xC055, Reset: 0x00, Name: FINT\_ROUTE4

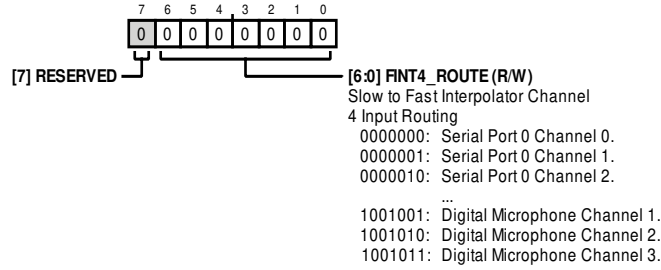

Table 109. Bit Descriptions for FINT\_ROUTE4

Bits	Bit Name	Settings	Description	Reset	Access
7	RESERVED		Reserved.	0x0	R
[6:0]	FINT4_ROUTE		Slow to Fast Interpolator Channel 4 Input Routing.	0x0	R/W
		0000000	Serial Port 0 Channel 0.		
		0000001	Serial Port 0 Channel 1.		
		0000010	Serial Port 0 Channel 2.		
		0000011	Serial Port 0 Channel 3.		
		0000100	Serial Port 0 Channel 4.		
		0000101	Serial Port 0 Channel 5.		
		0000110	Serial Port 0 Channel 6.		
		0000111	Serial Port 0 Channel 7.		
		0001000	Serial Port 0 Channel 8.		
		0001001	Serial Port 0 Channel 9.		
		0001010	Serial Port 0 Channel 10.		
		0001011	Serial Port 0 Channel 11.		
		0001100	Serial Port 0 Channel 12.		
		0001101	Serial Port 0 Channel 13.		
		0001110	Serial Port 0 Channel 14.		
		0001111	Serial Port 0 Channel 15.		
		0100000	FastDSP Channel 0.		
		0100001	FastDSP Channel 1.		
		0100010	FastDSP Channel 2.		
		0100011	FastDSP Channel 3.		
		0100100	FastDSP Channel 4.		
		0100101	FastDSP Channel 5.		
		0100110	FastDSP Channel 6.		
		0100111	FastDSP Channel 7.		
		0101000	FastDSP Channel 8.		
		0101001	FastDSP Channel 9.		
		0101010	FastDSP Channel 10.		
		0101011	FastDSP Channel 11.		
		0101100	FastDSP Channel 12.		
		0101101	FastDSP Channel 13.		
		0101110	FastDSP Channel 14.		
		0101111	FastDSP Channel 15.		

Bits	Bit Name	Settings	Description	Reset	Access
		0110000	SigmaDSP Channel 0.		
		0110001	SigmaDSP Channel 1.		
		0110010	SigmaDSP Channel 2.		
		0110011	SigmaDSP Channel 3.		
		0110100	SigmaDSP Channel 4.		
		0110101	SigmaDSP Channel 5.		
		0110110	SigmaDSP Channel 6.		
		0110111	SigmaDSP Channel 7.		
		0111000	SigmaDSP Channel 8.		
		0111001	SigmaDSP Channel 9.		
		0111010	SigmaDSP Channel 10.		
		0111011	SigmaDSP Channel 11.		
		0111100	SigmaDSP Channel 12.		
		0111101	SigmaDSP Channel 13.		
		0111110	SigmaDSP Channel 14.		
		0111111	SigmaDSP Channel 15.		
		1000000	Input ASRC Channel 0.		
		1000001	Input ASRC Channel 1.		
		1000010	Input ASRC Channel 2.		
		1000011	Input ASRC Channel 3.		
		1000100	ADC Channel 0.		
		1000101	ADC Channel 1.		
		1001000	Digital Microphone Channel 0.		
		1001001	Digital Microphone Channel 1.		
		1001010	Digital Microphone Channel 2.		
		1001011	Digital Microphone Channel 3.		

**SLOW TO FAST INTERPOLATOR CHANNEL 5 INPUT ROUTING REGISTER**

Address: 0xC056, Reset: 0x00, Name: FINT\_ROUTE5

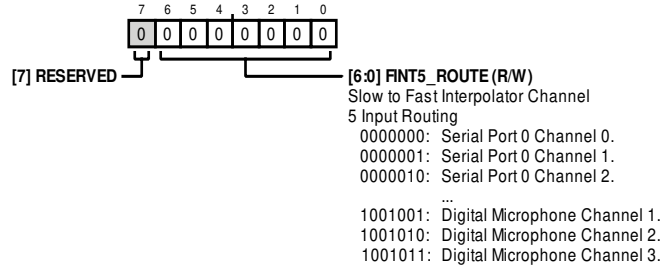

**Table 110. Bit Descriptions for FINT\_ROUTE5**

Bits	Bit Name	Settings	Description	Reset	Access
7	RESERVED		Reserved.	0x0	R
[6:0]	FINT5_ROUTE		Slow to Fast Interpolator Channel 5 Input Routing.	0x0	R/W
		0000000	Serial Port 0 Channel 0.		
		0000001	Serial Port 0 Channel 1.		
		0000010	Serial Port 0 Channel 2.		
		0000011	Serial Port 0 Channel 3.		
		0000100	Serial Port 0 Channel 4.		
		0000101	Serial Port 0 Channel 5.		
		0000110	Serial Port 0 Channel 6.		
		0000111	Serial Port 0 Channel 7.		
		0001000	Serial Port 0 Channel 8.		
		0001001	Serial Port 0 Channel 9.		
		0001010	Serial Port 0 Channel 10.		
		0001011	Serial Port 0 Channel 11.		
		0001100	Serial Port 0 Channel 12.		
		0001101	Serial Port 0 Channel 13.		
		0001110	Serial Port 0 Channel 14.		
		0001111	Serial Port 0 Channel 15.		
		0100000	FastDSP Channel 0.		
		0100001	FastDSP Channel 1.		
		0100010	FastDSP Channel 2.		
		0100011	FastDSP Channel 3.		
		0100100	FastDSP Channel 4.		
		0100101	FastDSP Channel 5.		
		0100110	FastDSP Channel 6.		
		0100111	FastDSP Channel 7.		
		0101000	FastDSP Channel 8.		
		0101001	FastDSP Channel 9.		
		0101010	FastDSP Channel 10.		
		0101011	FastDSP Channel 11.		
		0101100	FastDSP Channel 12.		
		0101101	FastDSP Channel 13.		
		0101110	FastDSP Channel 14.		
		0101111	FastDSP Channel 15.		

Bits	Bit Name	Settings	Description	Reset	Access
		0110000	SigmaDSP Channel 0.		
		0110001	SigmaDSP Channel 1.		
		0110010	SigmaDSP Channel 2.		
		0110011	SigmaDSP Channel 3.		
		0110100	SigmaDSP Channel 4.		
		0110101	SigmaDSP Channel 5.		
		0110110	SigmaDSP Channel 6.		
		0110111	SigmaDSP Channel 7.		
		0111000	SigmaDSP Channel 8.		
		0111001	SigmaDSP Channel 9.		
		0111010	SigmaDSP Channel 10.		
		0111011	SigmaDSP Channel 11.		
		0111100	SigmaDSP Channel 12.		
		0111101	SigmaDSP Channel 13.		
		0111110	SigmaDSP Channel 14.		
		0111111	SigmaDSP Channel 15.		
		1000000	Input ASRC Channel 0.		
		1000001	Input ASRC Channel 1.		
		1000010	Input ASRC Channel 2.		
		1000011	Input ASRC Channel 3.		
		1000100	ADC Channel 0.		
		1000101	ADC Channel 1.		
		1001000	Digital Microphone Channel 0.		
		1001001	Digital Microphone Channel 1.		
		1001010	Digital Microphone Channel 2.		
		1001011	Digital Microphone Channel 3.		

**SLOW TO FAST INTERPOLATOR CHANNEL 6 INPUT ROUTING REGISTER**

Address: 0xC057, Reset: 0x00, Name: FINT\_ROUTE6

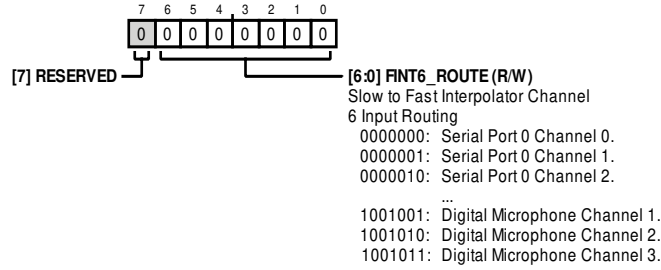

Table 111. Bit Descriptions for FINT\_ROUTE6

Bits	Bit Name	Settings	Description	Reset	Access
7	RESERVED		Reserved.	0x0	R
[6:0]	FINT6_ROUTE		Slow to Fast Interpolator Channel 6 Input Routing.	0x0	R/W
		0000000	Serial Port 0 Channel 0.		
		0000001	Serial Port 0 Channel 1.		
		0000010	Serial Port 0 Channel 2.		
		0000011	Serial Port 0 Channel 3.		
		0000100	Serial Port 0 Channel 4.		
		0000101	Serial Port 0 Channel 5.		
		0000110	Serial Port 0 Channel 6.		
		0000111	Serial Port 0 Channel 7.		
		0001000	Serial Port 0 Channel 8.		
		0001001	Serial Port 0 Channel 9.		
		0001010	Serial Port 0 Channel 10.		
		0001011	Serial Port 0 Channel 11.		
		0001100	Serial Port 0 Channel 12.		
		0001101	Serial Port 0 Channel 13.		
		0001110	Serial Port 0 Channel 14.		
		0001111	Serial Port 0 Channel 15.		
		0100000	FastDSP Channel 0.		
		0100001	FastDSP Channel 1.		
		0100010	FastDSP Channel 2.		
		0100011	FastDSP Channel 3.		
		0100100	FastDSP Channel 4.		
		0100101	FastDSP Channel 5.		
		0100110	FastDSP Channel 6.		
		0100111	FastDSP Channel 7.		
		0101000	FastDSP Channel 8.		
		0101001	FastDSP Channel 9.		
		0101010	FastDSP Channel 10.		
		0101011	FastDSP Channel 11.		
		0101100	FastDSP Channel 12.		
		0101101	FastDSP Channel 13.		
		0101110	FastDSP Channel 14.		
		0101111	FastDSP Channel 15.		



Bits	Bit Name	Settings	Description	Reset	Access
		0110000	SigmaDSP Channel 0.		
		0110001	SigmaDSP Channel 1.		
		0110010	SigmaDSP Channel 2.		
		0110011	SigmaDSP Channel 3.		
		0110100	SigmaDSP Channel 4.		
		0110101	SigmaDSP Channel 5.		
		0110110	SigmaDSP Channel 6.		
		0110111	SigmaDSP Channel 7.		
		0111000	SigmaDSP Channel 8.		
		0111001	SigmaDSP Channel 9.		
		0111010	SigmaDSP Channel 10.		
		0111011	SigmaDSP Channel 11.		
		0111100	SigmaDSP Channel 12.		
		0111101	SigmaDSP Channel 13.		
		0111110	SigmaDSP Channel 14.		
		0111111	SigmaDSP Channel 15.		
		1000000	Input ASRC Channel 0.		
		1000001	Input ASRC Channel 1.		
		1000010	Input ASRC Channel 2.		
		1000011	Input ASRC Channel 3.		
		1000100	ADC Channel 0.		
		1000101	ADC Channel 1.		
		1001000	Digital Microphone Channel 0.		
		1001001	Digital Microphone Channel 1.		
		1001010	Digital Microphone Channel 2.		
		1001011	Digital Microphone Channel 3.		

**SLOW TO FAST INTERPOLATOR CHANNEL 7 INPUT ROUTING REGISTER**

Address: 0xC058, Reset: 0x00, Name: FINT\_ROUTE7

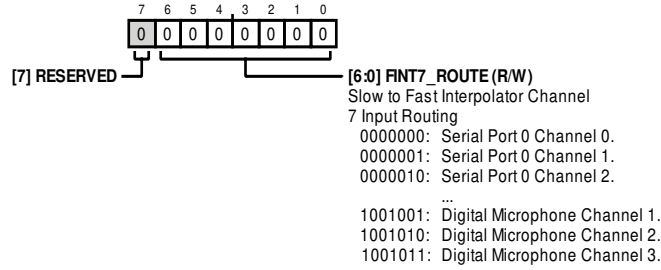

Table 112. Bit Descriptions for FINT\_ROUTE7

Bits	Bit Name	Settings	Description	Reset	Access
7	RESERVED		Reserved.	0x0	R
[6:0]	FINT7_ROUTE		Slow to Fast Interpolator Channel 7 Input Routing.	0x0	R/W
		0000000	Serial Port 0 Channel 0.		
		0000001	Serial Port 0 Channel 1.		
		0000010	Serial Port 0 Channel 2.		
		0000011	Serial Port 0 Channel 3.		
		0000100	Serial Port 0 Channel 4.		
		0000101	Serial Port 0 Channel 5.		
		0000110	Serial Port 0 Channel 6.		
		0000111	Serial Port 0 Channel 7.		
		0001000	Serial Port 0 Channel 8.		
		0001001	Serial Port 0 Channel 9.		
		0001010	Serial Port 0 Channel 10.		
		0001011	Serial Port 0 Channel 11.		
		0001100	Serial Port 0 Channel 12.		
		0001101	Serial Port 0 Channel 13.		
		0001110	Serial Port 0 Channel 14.		
		0001111	Serial Port 0 Channel 15.		
		0100000	FastDSP Channel 0.		
		0100001	FastDSP Channel 1.		
		0100010	FastDSP Channel 2.		
		0100011	FastDSP Channel 3.		
		0100100	FastDSP Channel 4.		
		0100101	FastDSP Channel 5.		
		0100110	FastDSP Channel 6.		
		0100111	FastDSP Channel 7.		
		0101000	FastDSP Channel 8.		
		0101001	FastDSP Channel 9.		
		0101010	FastDSP Channel 10.		
		0101011	FastDSP Channel 11.		
		0101100	FastDSP Channel 12.		
		0101101	FastDSP Channel 13.		
		0101110	FastDSP Channel 14.		
		0101111	FastDSP Channel 15.		

Bits	Bit Name	Settings	Description	Reset	Access
		0110000	SigmaDSP Channel 0.		
		0110001	SigmaDSP Channel 1.		
		0110010	SigmaDSP Channel 2.		
		0110011	SigmaDSP Channel 3.		
		0110100	SigmaDSP Channel 4.		
		0110101	SigmaDSP Channel 5.		
		0110110	SigmaDSP Channel 6.		
		0110111	SigmaDSP Channel 7.		
		0111000	SigmaDSP Channel 8.		
		0111001	SigmaDSP Channel 9.		
		0111010	SigmaDSP Channel 10.		
		0111011	SigmaDSP Channel 11.		
		0111100	SigmaDSP Channel 12.		
		0111101	SigmaDSP Channel 13.		
		0111110	SigmaDSP Channel 14.		
		0111111	SigmaDSP Channel 15.		
		1000000	Input ASRC Channel 0.		
		1000001	Input ASRC Channel 1.		
		1000010	Input ASRC Channel 2.		
		1000011	Input ASRC Channel 3.		
		1000100	ADC Channel 0.		
		1000101	ADC Channel 1.		
		1001000	Digital Microphone Channel 0.		
		1001001	Digital Microphone Channel 1.		
		1001010	Digital Microphone Channel 2.		
		1001011	Digital Microphone Channel 3.		

**INPUT ASRC CONTROL, SOURCE, AND RATE SELECTION REGISTER**

Address: 0xC059, Reset: 0x02, Name: ASRCI\_CTRL

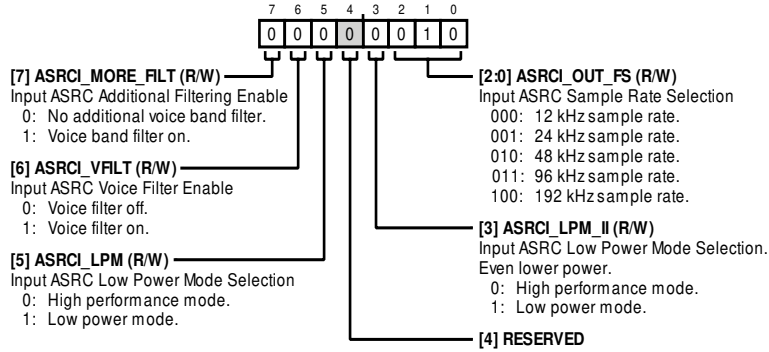
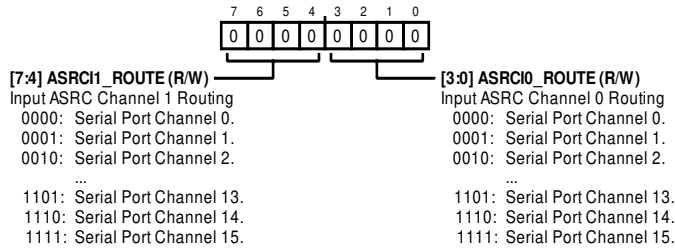

Table 113. Bit Descriptions for ASRCI\_CTRL

Bits	Bit Name	Settings	Description	Reset	Access
7	ASRCI_MORE_FLT	0 1	Input ASRC Additional Filtering Enable. This bit can enable additional filtering within the ASRC that can provide higher performance under some conditions. No additional voice band filter. Voice band filter on.	0x0	R/W
6	ASRCI_VFILT	0 1	Input ASRC Voice Filter Enable. Voice filter off. Voice filter on.	0x0	R/W
5	ASRCI_LPM	0 1	Input ASRC Low Power Mode Selection. High performance mode. Low power mode.	0x0	R/W
4	RESERVED		Reserved.	0x0	R/W
3	ASRCI_LPM_II	0 1	Input ASRC Low Power Mode Selection. Even lower power. High performance mode. Low power mode.	0x0	R/W
[2:0]	ASRCI_OUT_FS	000 001 010 011 100	Input ASRC Sample Rate Selection. 12 kHz sample rate. 24 kHz sample rate. 48 kHz sample rate. 96 kHz sample rate. 192 kHz sample rate.	0x2	R/W

**INPUT ASRC CHANNEL 0 AND CHANNEL 1 INPUT ROUTING REGISTER**

Address: 0xC05A, Reset: 0x00, Name: ASRCI\_ROUTE01

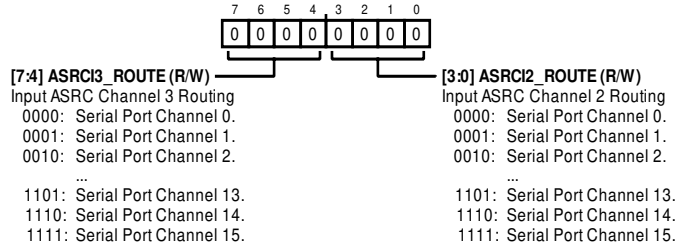

**Table 114. Bit Descriptions for ASRCI\_ROUTE01**

Bits	Bit Name	Settings	Description	Reset	Access
[7:4]	ASRCI1_ROUTE	0000 0001 0010 0011 0100 0101 0110 0111 1000 1001 1010 1011 1100 1101 1110 1111	Input ASRC Channel 1 Routing. Serial Port Channel 0. Serial Port Channel 1. Serial Port Channel 2. Serial Port Channel 3. Serial Port Channel 4. Serial Port Channel 5. Serial Port Channel 6. Serial Port Channel 7. Serial Port Channel 8. Serial Port Channel 9. Serial Port Channel 10. Serial Port Channel 11. Serial Port Channel 12. Serial Port Channel 13. Serial Port Channel 14. Serial Port Channel 15.	0x0	R/W
[3:0]	ASRCI0_ROUTE	0000 0001 0010 0011 0100 0101 0110 0111 1000 1001 1010 1011 1100 1101 1110 1111	Input ASRC Channel 0 Routing. Serial Port Channel 0. Serial Port Channel 1. Serial Port Channel 2. Serial Port Channel 3. Serial Port Channel 4. Serial Port Channel 5. Serial Port Channel 6. Serial Port Channel 7. Serial Port Channel 8. Serial Port Channel 9. Serial Port Channel 10. Serial Port Channel 11. Serial Port Channel 12. Serial Port Channel 13. Serial Port Channel 14. Serial Port Channel 15.	0x0	R/W

**INPUT ASRC CHANNEL 2 AND CHANNEL 3 INPUT ROUTING REGISTER**

Address: 0xC05B, Reset: 0x00, Name: ASRCI\_ROUTE23



**Table 115. Bit Descriptions for ASRCI\_ROUTE23**

Bits	Bit Name	Settings	Description	Reset	Access
[7:4]	ASRCI3_ROUTE	0000 0001 0010 0011 0100 0101 0110 0111 1000 1001 1010 1011 1100 1101 1110 1111	Input ASRC Channel 3 Routing.  Serial Port Channel 0. Serial Port Channel 1. Serial Port Channel 2. Serial Port Channel 3. Serial Port Channel 4. Serial Port Channel 5. Serial Port Channel 6. Serial Port Channel 7. Serial Port Channel 8. Serial Port Channel 9. Serial Port Channel 10. Serial Port Channel 11. Serial Port Channel 12. Serial Port Channel 13. Serial Port Channel 14. Serial Port Channel 15.	0x0	R/W
[3:0]	ASRCI2_ROUTE	0000 0001 0010 0011 0100 0101 0110 0111 1000 1001 1010 1011 1100 1101 1110 1111	Input ASRC Channel 2 Routing.  Serial Port Channel 0. Serial Port Channel 1. Serial Port Channel 2. Serial Port Channel 3. Serial Port Channel 4. Serial Port Channel 5. Serial Port Channel 6. Serial Port Channel 7. Serial Port Channel 8. Serial Port Channel 9. Serial Port Channel 10. Serial Port Channel 11. Serial Port Channel 12. Serial Port Channel 13. Serial Port Channel 14. Serial Port Channel 15.	0x0	R/W

**OUTPUT ASRC CONTROL REGISTER**

Address: 0xC05C, Reset: 0x02, Name: ASRCO\_CTRL

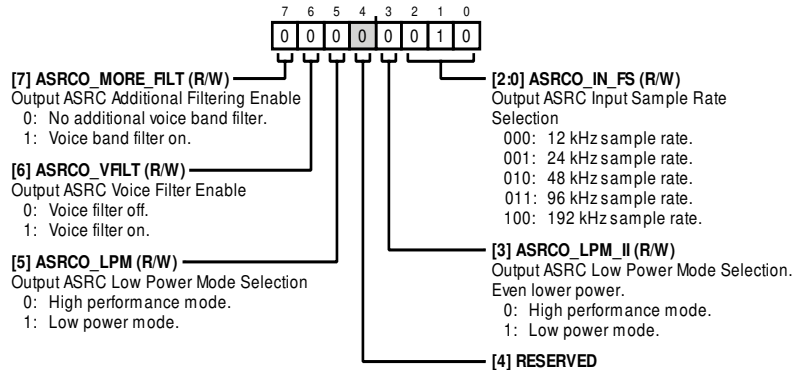
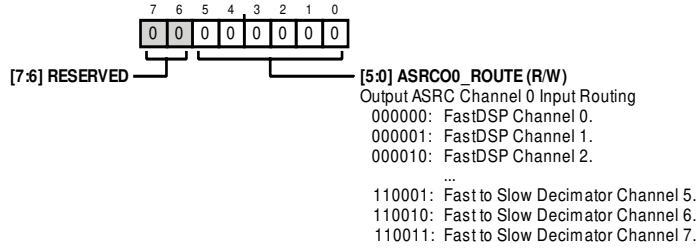

Table 116. Bit Descriptions for ASRCO\_CTRL

Bits	Bit Name	Settings	Description	Reset	Access
7	ASRCO_MORE_FILT	0 1	Output ASRC Additional Filtering Enable. This bit can enable additional filtering within the ASRC that can provide higher performance under some conditions. No additional voice band filter. Voice band filter on.	0x0	R/W
6	ASRCO_VFILT	0 1	Output ASRC Voice Filter Enable. Voice filter off. Voice filter on.	0x0	R/W
5	ASRCO_LPM	0 1	Output ASRC Low Power Mode Selection. High performance mode. Low power mode.	0x0	R/W
4	RESERVED		Reserved.	0x0	R/W
3	ASRCO_LPM_II	0 1	Output ASRC Low Power Mode Selection. Even lower power. High performance mode. Low power mode.	0x0	R/W
[2:0]	ASRCO_IN_FS	000 001 010 011 100	Output ASRC Input Sample Rate Selection. 12 kHz sample rate. 24 kHz sample rate. 48 kHz sample rate. 96 kHz sample rate. 192 kHz sample rate.	0x2	R/W

**OUTPUT ASRC CHANNEL 0 INPUT ROUTING REGISTER**

Address: 0xC05D, Reset: 0x00, Name: ASRCO\_ROUTE0



**Table 117. Bit Descriptions for ASRCO\_ROUTE0**

Bits	Bit Name	Settings	Description	Reset	Access
[7:6]	RESERVED		Reserved.	0x0	R
[5:0]	ASRCO_ROUTE		Output ASRC Channel 0 Input Routing.	0x0	R/W
		000000	FastDSP Channel 0.		
		000001	FastDSP Channel 1.		
		000010	FastDSP Channel 2.		
		000011	FastDSP Channel 3.		
		000100	FastDSP Channel 4.		
		000101	FastDSP Channel 5.		
		000110	FastDSP Channel 6.		
		000111	FastDSP Channel 7.		
		001000	FastDSP Channel 8.		
		001001	FastDSP Channel 9.		
		001010	FastDSP Channel 10.		
		001011	FastDSP Channel 11.		
		001100	FastDSP Channel 12.		
		001101	FastDSP Channel 13.		
		001110	FastDSP Channel 14.		
		001111	FastDSP Channel 15.		
		010000	SigmaDSP Channel 0.		
		010001	SigmaDSP Channel 1.		
		010010	SigmaDSP Channel 2.		
		010011	SigmaDSP Channel 3.		
		010100	SigmaDSP Channel 4.		
		010101	SigmaDSP Channel 5.		
		010110	SigmaDSP Channel 6.		
		010111	SigmaDSP Channel 7.		
		011000	SigmaDSP Channel 8.		
		011001	SigmaDSP Channel 9.		
		011010	SigmaDSP Channel 10.		
		011011	SigmaDSP Channel 11.		
		011100	SigmaDSP Channel 12.		
		011101	SigmaDSP Channel 13.		
		011110	SigmaDSP Channel 14.		
		011111	SigmaDSP Channel 15.		
		100000	ADC Channel 0.		
		100001	ADC Channel 1.		



Bits	Bit Name	Settings	Description	Reset	Access
		100100	Digital Microphone Channel 0.		
		100101	Digital Microphone Channel 1.		
		100110	Digital Microphone Channel 2.		
		100111	Digital Microphone Channel 3.		
		101100	Fast to Slow Decimator Channel 0.		
		101101	Fast to Slow Decimator Channel 1.		
		101110	Fast to Slow Decimator Channel 2.		
		101111	Fast to Slow Decimator Channel 3.		
		110000	Fast to Slow Decimator Channel 4.		
		110001	Fast to Slow Decimator Channel 5.		
		110010	Fast to Slow Decimator Channel 6.		
		110011	Fast to Slow Decimator Channel 7.		

**OUTPUT ASRC CHANNEL 1 INPUT ROUTING REGISTER**

Address: 0xC05E, Reset: 0x00, Name: ASRCO\_ROUTE1

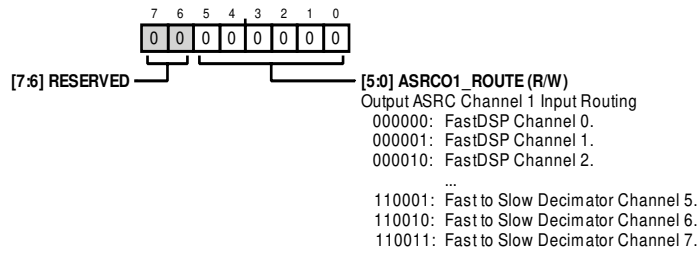

Table 118. Bit Descriptions for ASRCO\_ROUTE1

Bits	Bit Name	Settings	Description	Reset	Access
[7:6]	RESERVED		Reserved.	0x0	R
[5:0]	ASRCO1_ROUTE	000000 000001 000010 000011 000100 000101 000110 000111 001000 001001 001010 001011 001100 001101 001110 001111	Output ASRC Channel 1 Input Routing. FastDSP Channel 0. FastDSP Channel 1. FastDSP Channel 2. FastDSP Channel 3. FastDSP Channel 4. FastDSP Channel 5. FastDSP Channel 6. FastDSP Channel 7. FastDSP Channel 8. FastDSP Channel 9. FastDSP Channel 10. FastDSP Channel 11. FastDSP Channel 12. FastDSP Channel 13. FastDSP Channel 14. FastDSP Channel 15.	0x0	R/W

Bits	Bit Name	Settings	Description	Reset	Access
		010000	SigmaDSP Channel 0.		
		010001	SigmaDSP Channel 1.		
		010010	SigmaDSP Channel 2.		
		010011	SigmaDSP Channel 3.		
		010100	SigmaDSP Channel 4.		
		010101	SigmaDSP Channel 5.		
		010110	SigmaDSP Channel 6.		
		010111	SigmaDSP Channel 7.		
		011000	SigmaDSP Channel 8.		
		011001	SigmaDSP Channel 9.		
		011010	SigmaDSP Channel 10.		
		011011	SigmaDSP Channel 11.		
		011100	SigmaDSP Channel 12.		
		011101	SigmaDSP Channel 13.		
		011110	SigmaDSP Channel 14.		
		011111	SigmaDSP Channel 15.		
		100000	ADC Channel 0.		
		100001	ADC Channel 1.		
		100100	Digital Microphone Channel 0.		
		100101	Digital Microphone Channel 1.		
		100110	Digital Microphone Channel 2.		
		100111	Digital Microphone Channel 3.		
		101100	Fast to Slow Decimator Channel 0.		
		101101	Fast to Slow Decimator Channel 1.		
		101110	Fast to Slow Decimator Channel 2.		
		101111	Fast to Slow Decimator Channel 3.		
		110000	Fast to Slow Decimator Channel 4.		
		110001	Fast to Slow Decimator Channel 5.		
		110010	Fast to Slow Decimator Channel 6.		
		110011	Fast to Slow Decimator Channel 7.		

**OUTPUT ASRC CHANNEL 2 INPUT ROUTING REGISTER**

Address: 0xC05F, Reset: 0x00, Name: ASRCO\_ROUTE2

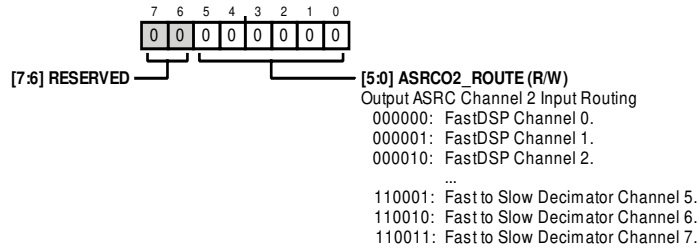

**Table 119. Bit Descriptions for ASRCO\_ROUTE2**

Bits	Bit Name	Settings	Description	Reset	Access
[7:6]	RESERVED		Reserved.	0x0	R
[5:0]	ASRCO2_ROUTE		Output ASRC Channel 2 Input Routing.	0x0	R/W
		000000	FastDSP Channel 0.		
		000001	FastDSP Channel 1.		
		000010	FastDSP Channel 2.		
		000011	FastDSP Channel 3.		
		000100	FastDSP Channel 4.		
		000101	FastDSP Channel 5.		
		000110	FastDSP Channel 6.		
		000111	FastDSP Channel 7.		
		001000	FastDSP Channel 8.		
		001001	FastDSP Channel 9.		
		001010	FastDSP Channel 10.		
		001011	FastDSP Channel 11.		
		001100	FastDSP Channel 12.		
		001101	FastDSP Channel 13.		
		001110	FastDSP Channel 14.		
		001111	FastDSP Channel 15.		
		010000	SigmaDSP Channel 0.		
		010001	SigmaDSP Channel 1.		
		010010	SigmaDSP Channel 2.		
		010011	SigmaDSP Channel 3.		
		010100	SigmaDSP Channel 4.		
		010101	SigmaDSP Channel 5.		
		010110	SigmaDSP Channel 6.		
		010111	SigmaDSP Channel 7.		
		011000	SigmaDSP Channel 8.		
		011001	SigmaDSP Channel 9.		
		011010	SigmaDSP Channel 10.		
		011011	SigmaDSP Channel 11.		
		011100	SigmaDSP Channel 12.		
		011101	SigmaDSP Channel 13.		
		011110	SigmaDSP Channel 14.		
		011111	SigmaDSP Channel 15.		
		100000	ADC Channel 0.		
		100001	ADC Channel 1.		

Bits	Bit Name	Settings	Description	Reset	Access
		100100	Digital Microphone Channel 0.		
		100101	Digital Microphone Channel 1.		
		100110	Digital Microphone Channel 2.		
		100111	Digital Microphone Channel 3.		
		101100	Fast to Slow Decimator Channel 0.		
		101101	Fast to Slow Decimator Channel 1.		
		101110	Fast to Slow Decimator Channel 2.		
		101111	Fast to Slow Decimator Channel 3.		
		110000	Fast to Slow Decimator Channel 4.		
		110001	Fast to Slow Decimator Channel 5.		
		110010	Fast to Slow Decimator Channel 6.		
		110011	Fast to Slow Decimator Channel 7.		

**OUTPUT ASRC CHANNEL 3 INPUT ROUTING REGISTER**

Address: 0xC060, Reset: 0x00, Name: ASRCO\_ROUTE3

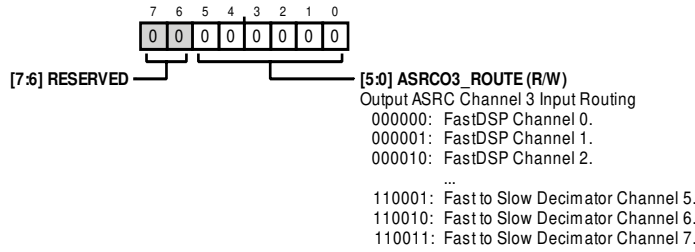

Table 120. Bit Descriptions for ASRCO\_ROUTE3

Bits	Bit Name	Settings	Description	Reset	Access
[7:6]	RESERVED		Reserved.	0x0	R
[5:0]	ASRCO3_ROUTE		Output ASRC Channel 3 Input Routing.	0x0	R/W
		000000	FastDSP Channel 0.		
		000001	FastDSP Channel 1.		
		000010	FastDSP Channel 2.		
		000011	FastDSP Channel 3.		
		000100	FastDSP Channel 4.		
		000101	FastDSP Channel 5.		
		000110	FastDSP Channel 6.		
		000111	FastDSP Channel 7.		
		001000	FastDSP Channel 8.		
		001001	FastDSP Channel 9.		
		001010	FastDSP Channel 10.		
		001011	FastDSP Channel 11.		
		001100	FastDSP Channel 12.		
		001101	FastDSP Channel 13.		
		001110	FastDSP Channel 14.		
		001111	FastDSP Channel 15.		
		010000	SigmaDSP Channel 0.		
		010001	SigmaDSP Channel 1.		
		010010	SigmaDSP Channel 2.		
		010011	SigmaDSP Channel 3.		
		010100	SigmaDSP Channel 4.		
		010101	SigmaDSP Channel 5.		

Bits	Bit Name	Settings	Description	Reset	Access
		010110	SigmaDSP Channel 6.		
		010111	SigmaDSP Channel 7.		
		011000	SigmaDSP Channel 8.		
		011001	SigmaDSP Channel 9.		
		011010	SigmaDSP Channel 10.		
		011011	SigmaDSP Channel 11.		
		011100	SigmaDSP Channel 12.		
		011101	SigmaDSP Channel 13.		
		011110	SigmaDSP Channel 14.		
		011111	SigmaDSP Channel 15.		
		100000	ADC Channel 0.		
		100001	ADC Channel 1.		
		100100	Digital Microphone Channel 0.		
		100101	Digital Microphone Channel 1.		
		100110	Digital Microphone Channel 2.		
		100111	Digital Microphone Channel 3.		
		101100	Fast to Slow Decimator Channel 0.		
		101101	Fast to Slow Decimator Channel 1.		
		101110	Fast to Slow Decimator Channel 2.		
		101111	Fast to Slow Decimator Channel 3.		
		110000	Fast to Slow Decimator Channel 4.		
		110001	Fast to Slow Decimator Channel 5.		
		110010	Fast to Slow Decimator Channel 6.		
		110011	Fast to Slow Decimator Channel 7.		

**FastDSP RUN REGISTER**

Address: 0xC061, Reset: 0x00, Name: FDSP\_RUN

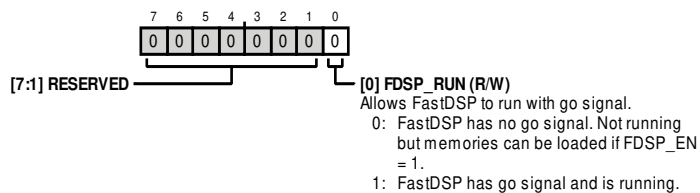

**Table 121. Bit Descriptions for FDSP\_RUN**

Bits	Bit Name	Settings	Description	Reset	Access
[7:1]	RESERVED		Reserved.	0x0	R
0	FDSP_RUN	0 1	Allows FastDSP to run with go signal. FastDSP has no go signal. Not running but memories can be loaded if FDSP_EN = 1. FastDSP has go signal and is running.	0x0	R/W

**FastDSP CURRENT BANK AND BANK RAMPING CONTROLS REGISTER**

Address: 0xC062, Reset: 0x70, Name: FDSP\_CTRL1

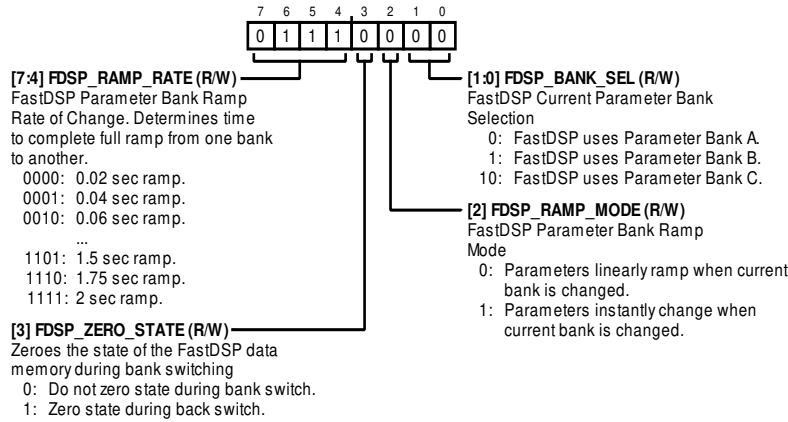
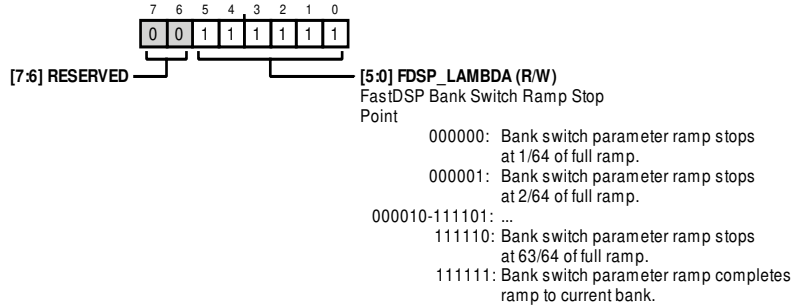

Table 122. Bit Descriptions for FDSP\_CTRL1

Bits	Bit Name	Settings	Description	Reset	Access
[7:4]	FDSP_RAMP_RATE	0000 0001 0010 0011 0100 0101 0110 0111 1000 1001 1010 1011 1100 1101 1110 1111	FastDSP Parameter Bank Ramp Rate of Change. Determines time to complete full ramp from one bank to another. 0.02 sec ramp. 0.04 sec ramp. 0.06 sec ramp. 0.08 sec ramp. 0.1 sec ramp. 0.15 sec ramp. 0.2 sec ramp. 0.25 sec ramp. 0.3 sec ramp. 0.5 sec ramp. 0.75 sec ramp. 1 sec ramp. 1.25 sec ramp. 1.5 sec ramp. 1.75 sec ramp. 2 sec ramp.	0x7	R/W
3	FDSP_ZERO_STATE	0 1	Zeroes the state of the FastDSP data memory during bank switching. When switching active parameter banks between two settings, zeroing the state of the bank prevents the new filter settings from being active on old data that is recirculating in filters. Zeroing the state may prevent filter instability or unwanted noises upon bank switching. Do not zero state during bank switch. Zero state during back switch.	0x0	R/W
2	FDSP_RAMP_MODE	0 1	FastDSP Parameter Bank Ramp Mode. Parameters linearly ramp when current bank is changed. Parameters instantly change when current bank is changed.	0x0	R/W
[1:0]	FDSP_BANK_SEL	0 1 10	FastDSP Current Parameter Bank Selection. FastDSP uses Parameter Bank A. FastDSP uses Parameter Bank B. FastDSP uses Parameter Bank C.	0x0	R/W

**FastDSP BANK RAMPING STOP POINT REGISTER**

Address: 0xC063, Reset: 0x3F, Name: FDSP\_CTRL2

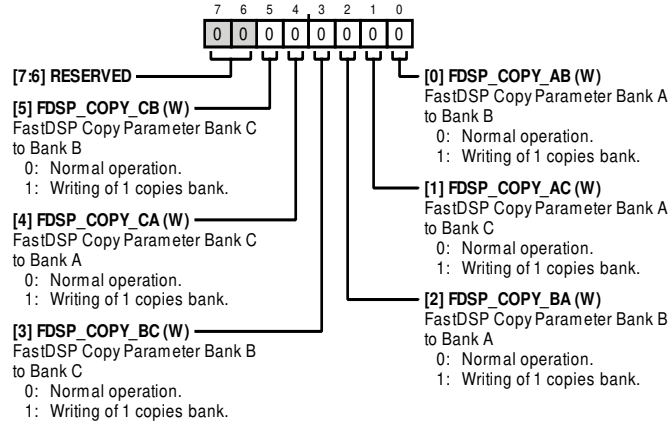

**Table 123. Bit Descriptions for FDSP\_CTRL2**

Bits	Bit Name	Settings	Description	Reset	Access
[7:6]	RESERVED		Reserved.	0x0	R
[5:0]	FDSP_LAMBDA	000000 000001 000010 to 111101 111110 111111	FastDSP Bank Switch Ramp Stop Point. Lambda is a 6-bit value representing the point along the linear interpolation curve between two banks at which the bank ramp switch stops. Where A represents coefficient values in the source bank, and B represents coefficient values in the destination bank: $0 = ((63/64) \times A + (1/64) \times B)$ , $1 = ((62/64) \times A + (2/64) \times B)$ , ... , $62 = ((1/64) \times A + (63/64) \times B)$ , $63 = B$ (default). Lambda can be updated on the fly via the control interface. To complete a bank switch, a value of 63 (default setting) must be set. Actual current ramp point (FDSP_CURRENT_LAMBDA: 0 to 63) can be read via a status register. When this point reaches 63, the bank switch is complete, and the current parameters used match the current bank. Actual step size of linear interpolation is ~12-bits (4096 steps). Parameters in banks ramped between do not change during a bank switch.  Bank switch parameter ramp stops at 1/64 of full ramp. Bank switch parameter ramp stops at 2/64 of full ramp. ... Bank switch parameter ramp stops at 63/64 of full ramp. Bank switch parameter ramp completes ramp to current bank.	0x3F	R/W

**FastDSP BANK COPYING REGISTER**

Address: 0xC064, Reset: 0x00, Name: FDSP\_CTRL3



**Table 124. Bit Descriptions for FDSP\_CTRL3**

Bits	Bit Name	Settings	Description	Reset	Access
[7:6]	RESERVED		Reserved.	0x0	R
5	FDSP_COPY_CB	0 1	FastDSP Copy Parameter Bank C to Bank B. Normal operation. Writing of 1 copies bank.	0x0	W
4	FDSP_COPY_CA	0 1	FastDSP Copy Parameter Bank C to Bank A. Normal operation. Writing of 1 copies bank.	0x0	W
3	FDSP_COPY_BC	0 1	FastDSP Copy Parameter Bank B to Bank C. Normal operation. Writing of 1 copies bank.	0x0	W
2	FDSP_COPY_BA	0 1	FastDSP Copy Parameter Bank B to Bank A. Normal operation. Writing of 1 copies bank.	0x0	W
1	FDSP_COPY_AC	0 1	FastDSP Copy Parameter Bank A to Bank C. Normal operation. Writing of 1 copies bank.	0x0	W
0	FDSP_COPY_AB	0 1	FastDSP Copy Parameter Bank A to Bank B. Normal operation. Writing of 1 copies bank.	0x0	W



**FastDSP FRAME RATE SOURCE REGISTER**

Address: 0xC065, Reset: 0x00, Name: FDSP\_CTRL4

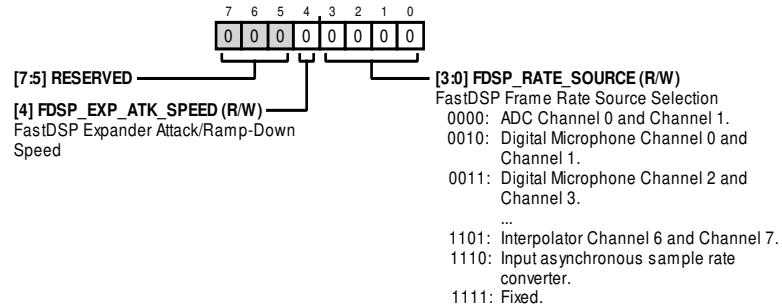

Table 125. Bit Descriptions for FDSP\_CTRL4

Bits	Bit Name	Settings	Description	Reset	Access
[7:5]	RESERVED		Reserved.	0x0	R
4	FDSP_EXP_ATK_SPEED		FastDSP Expander Attack/Ramp-Down Speed.	0x0	R/W
[3:0]	FDSP_RATE_SOURCE		FastDSP Frame Rate Source Selection.	0x0	R/W
		0000	ADC Channel 0 and Channel 1.		
		0010	Digital Microphone Channel 0 and Channel 1.		
		0011	Digital Microphone Channel 2 and Channel 3.		
		0110	Serial Audio Interface 0.		
		1010	Interpolator Channel 0 and Channel 1.		
		1011	Interpolator Channel 2 and Channel 3.		
		1100	Interpolator Channel 4 and Channel 5.		
		1101	Interpolator Channel 6 and Channel 7.		
		1110	Input asynchronous sample rate converter.		
		1111	Fixed.		

**FastDSP FIXED RATE DIVISION MSBs REGISTER**

Address: 0xC066, Reset: 0x00, Name: FDSP\_CTRL5

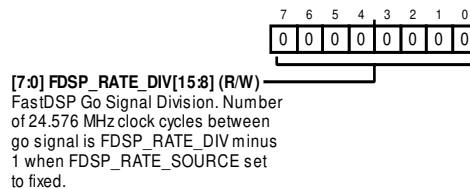
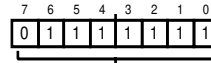

Table 126. Bit Descriptions for FDSP\_CTRL5

Bits	Bit Name	Settings	Description	Reset	Access
[7:0]	FDSP_RATE_DIV[15:8]		FastDSP Go Signal Division. Number of 24.576 MHz clock cycles between go signal is FDSP_RATE_DIV minus 1 when FDSP_RATE_SOURCE set to fixed.	0x0	R/W

**FastDSP FIXED RATE DIVISION LSBs REGISTER**

Address: 0xC067, Reset: 0x7F, Name: FDSP\_CTRL6



[7:0] **FDSP\_RATE\_DIV[7:0]** (R/W)  
 FastDSP Go Signal Division. Number of 24.576 MHz clock cycles between go signal is FDSP\_RATE\_DIV minus 1 when FDSP\_RATE\_SOURCE set to fixed.

Table 127. Bit Descriptions for FDSP\_CTRL6

Bits	Bit Name	Settings	Description	Reset	Access
[7:0]	FDSP_RATE_DIV[7:0]		FastDSP Go Signal Division. Number of 24.576 MHz clock cycles between go signal is FDSP_RATE_DIV minus 1 when FDSP_RATE_SOURCE set to fixed.	0x7F	R/W

**FastDSP MODULO N COUNTER FOR LOWER RATE CONDITIONAL EXECUTION REGISTER**

Address: 0xC068, Reset: 0x00, Name: FDSP\_CTRL7

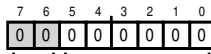

[7:6] RESERVED

[5:0] **FDSP\_MOD\_N** (R/W)  
 FastDSP Modulo N Counter Reset for Conditional Execution.

Table 128. Bit Descriptions for FDSP\_CTRL7

Bits	Bit Name	Settings	Description	Reset	Access
[7:6]	RESERVED		Reserved.	0x0	R
[5:0]	FDSP_MOD_N		FastDSP Modulo N Counter Reset for Conditional Execution.	0x0	R/W

### FastDSP GENERIC CONDITIONAL EXECUTION REGISTERS

Address: 0xC069, Reset: 0x00, Name: FDSP\_CTRL8

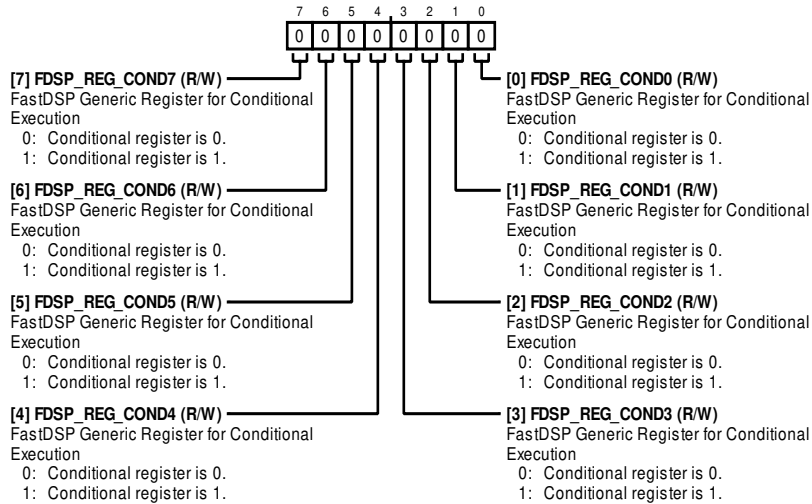

Table 129. Bit Descriptions for FDSP\_CTRL8

Bits	Bit Name	Settings	Description	Reset	Access
7	FDSP_REG_COND7	0 1	FastDSP Generic Register for Conditional Execution. The value of this register can be used for conditional instruction execution in the FastDSP. 0 Conditional register is 0. 1 Conditional register is 1.	0x0	R/W
6	FDSP_REG_COND6	0 1	FastDSP Generic Register for Conditional Execution. The value of this register can be used for conditional instruction execution in the FastDSP. 0 Conditional register is 0. 1 Conditional register is 1.	0x0	R/W
5	FDSP_REG_COND5	0 1	FastDSP Generic Register for Conditional Execution. The value of this register can be used for conditional instruction execution in the FastDSP. 0 Conditional register is 0. 1 Conditional register is 1.	0x0	R/W
4	FDSP_REG_COND4	0 1	FastDSP Generic Register for Conditional Execution. The value of this register can be used for conditional instruction execution in the FastDSP. 0 Conditional register is 0. 1 Conditional register is 1.	0x0	R/W
3	FDSP_REG_COND3	0 1	FastDSP Generic Register for Conditional Execution. The value of this register can be used for conditional instruction execution in the FastDSP. 0 Conditional register is 0. 1 Conditional register is 1.	0x0	R/W
2	FDSP_REG_COND2	0 1	FastDSP Generic Register for Conditional Execution. The value of this register can be used for conditional instruction execution in the FastDSP. 0 Conditional register is 0. 1 Conditional register is 1.	0x0	R/W
1	FDSP_REG_COND1	0 1	FastDSP Generic Register for Conditional Execution. The value of this register can be used for conditional instruction execution in the FastDSP. 0 Conditional register is 0. 1 Conditional register is 1.	0x0	R/W
0	FDSP_REG_COND0	0 1	FastDSP Generic Register for Conditional Execution. The value of this register can be used for conditional instruction execution in the FastDSP. 0 Conditional register is 0. 1 Conditional register is 1.	0x0	R/W

**FastDSP SAFELoad ADDRESS REGISTER**

Address: 0xC06A, Reset: 0x00, Name: FDSP\_SL\_ADDR

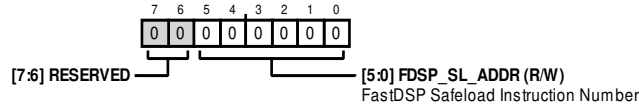

Table 130. Bit Descriptions for FDSP\_SL\_ADDR

Bits	Bit Name	Settings	Description	Reset	Access
[7:6]	RESERVED		Reserved.	0x0	R
[5:0]	FDSP_SL_ADDR		FastDSP Safeload Instruction Number	0x0	R/W

**FastDSP SAFELoad PARAMETER 0 VALUE REGISTERS**

Address: 0xC06B, Reset: 0x00, Name: FDSP\_SL\_P0\_3

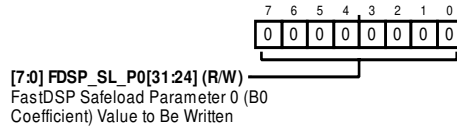

Table 131. Bit Descriptions for FDSP\_SL\_P0\_3

Bits	Bit Name	Settings	Description	Reset	Access
[7:0]	FDSP_SL_P0[31:24]		FastDSP Safeload Parameter 0 (B0 Coefficient) Value to Be Written	0x0	R/W

Address: 0xC06C, Reset: 0x00, Name: FDSP\_SL\_P0\_2

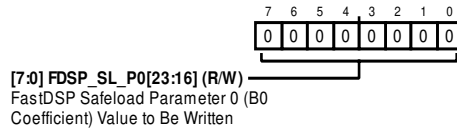

Table 132. Bit Descriptions for FDSP\_SL\_P0\_2

Bits	Bit Name	Settings	Description	Reset	Access
[7:0]	FDSP_SL_P0[23:16]		FastDSP Safeload Parameter 0 (B0 Coefficient) Value to Be Written	0x0	R/W

Address: 0xC06D, Reset: 0x00, Name: FDSP\_SL\_P0\_1

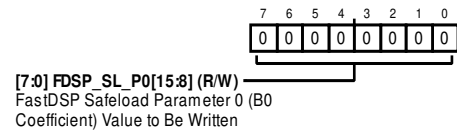
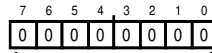

Table 133. Bit Descriptions for FDSP\_SL\_P0\_1

Bits	Bit Name	Settings	Description	Reset	Access
[7:0]	FDSP_SL_P0[15:8]		FastDSP Safeload Parameter 0 (B0 Coefficient) Value to Be Written	0x0	R/W

Address: 0xC06E, Reset: 0x00, Name: FDSP\_SL\_P0\_0



[7:0] FDSP\_SL\_P0[7:0] (R/W)  
FastDSP Safeload Parameter 0 (B0  
Coefficient) Value to Be Written

Table 134. Bit Descriptions for FDSP\_SL\_P0\_0

Bits	Bit Name	Settings	Description	Reset	Access
[7:0]	FDSP_SL_P0[7:0]		FastDSP Safeload Parameter 0 (B0 Coefficient) Value to Be Written	0x0	R/W

**FastDSP SAFELOAD PARAMETER 1 VALUE REGISTERS**

Address: 0xC06F, Reset: 0x00, Name: FDSP\_SL\_P1\_3

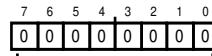

[7:0] FDSP\_SL\_P1[31:24] (R/W)  
FastDSP Safeload Parameter 1 (B1  
Coefficient) Value to Be Written

Table 135. Bit Descriptions for FDSP\_SL\_P1\_3

Bits	Bit Name	Settings	Description	Reset	Access
[7:0]	FDSP_SL_P1[31:24]		FastDSP Safeload Parameter 1 (B1 Coefficient) Value to Be Written	0x0	R/W

Address: 0xC070, Reset: 0x00, Name: FDSP\_SL\_P1\_2

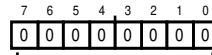

[7:0] FDSP\_SL\_P1[23:16] (R/W)  
FastDSP Safeload Parameter 1 (B1  
Coefficient) Value to Be Written

Table 136. Bit Descriptions for FDSP\_SL\_P1\_2

Bits	Bit Name	Settings	Description	Reset	Access
[7:0]	FDSP_SL_P1[23:16]		FastDSP Safeload Parameter 1 (B1 Coefficient) Value to Be Written	0x0	R/W

Address: 0xC071, Reset: 0x00, Name: FDSP\_SL\_P1\_1

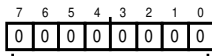

[7:0] FDSP\_SL\_P1[15:8] (R/W)  
FastDSP Safeload Parameter 1 (B1  
Coefficient) Value to Be Written

Table 137. Bit Descriptions for FDSP\_SL\_P1\_1

Bits	Bit Name	Settings	Description	Reset	Access
[7:0]	FDSP_SL_P1[15:8]		FastDSP Safeload Parameter 1 (B1 Coefficient) Value to Be Written	0x0	R/W

Address: 0xC072, Reset: 0x00, Name: FDSP\_SL\_P1\_0

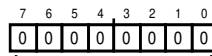

[7:0] FDSP\_SL\_P1[7:0] (R/W)  
FastDSP Safeload Parameter 1 (B1  
Coefficient) Value to Be Written

Table 138. Bit Descriptions for FDSP\_SL\_P1\_0

Bits	Bit Name	Settings	Description	Reset	Access
[7:0]	FDSP_SL_P1[7:0]		FastDSP Safeload Parameter 1 (B1 Coefficient) Value to Be Written	0x0	R/W

**FastDSP SAFELOAD PARAMETER 2 VALUE REGISTERS**

Address: 0xC073, Reset: 0x00, Name: FDSP\_SL\_P2\_3

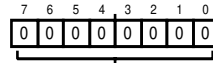

[7:0] FDSP\_SL\_P2[31:24] (R/W)  
FastDSP Safeload Parameter 2 (B2 Coefficient) Value to Be Written

Table 139. Bit Descriptions for FDSP\_SL\_P2\_3

Bits	Bit Name	Settings	Description	Reset	Access
[7:0]	FDSP_SL_P2[31:24]		FastDSP Safeload Parameter 2 (B2 Coefficient) Value to Be Written	0x0	R/W

Address: 0xC074, Reset: 0x00, Name: FDSP\_SL\_P2\_2

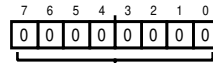

[7:0] FDSP\_SL\_P2[23:16] (R/W)  
FastDSP Safeload Parameter 2 (B2 Coefficient) Value to Be Written

Table 140. Bit Descriptions for FDSP\_SL\_P2\_2

Bits	Bit Name	Settings	Description	Reset	Access
[7:0]	FDSP_SL_P2[23:16]		FastDSP Safeload Parameter 2 (B2 Coefficient) Value to Be Written	0x0	R/W

Address: 0xC075, Reset: 0x00, Name: FDSP\_SL\_P2\_1

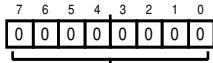

[7:0] FDSP\_SL\_P2[15:8] (R/W)  
FastDSP Safeload Parameter 2 (B2 Coefficient) Value to Be Written

Table 141. Bit Descriptions for FDSP\_SL\_P2\_1

Bits	Bit Name	Settings	Description	Reset	Access
[7:0]	FDSP_SL_P2[15:8]		FastDSP Safeload Parameter 2 (B2 Coefficient) Value to Be Written	0x0	R/W

Address: 0xC076, Reset: 0x00, Name: FDSP\_SL\_P2\_0

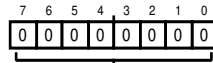

[7:0] FDSP\_SL\_P2[7:0] (R/W)  
FastDSP Safeload Parameter 2 (B2 Coefficient) Value to Be Written

Table 142. Bit Descriptions for FDSP\_SL\_P2\_0

Bits	Bit Name	Settings	Description	Reset	Access
[7:0]	FDSP_SL_P2[7:0]		FastDSP Safeload Parameter 2 (B2 Coefficient) Value to Be Written	0x0	R/W

**FastDSP SAFELoad PARAMETER 3 VALUE REGISTERS**

Address: 0xC077, Reset: 0x00, Name: FDSP\_SL\_P3\_3

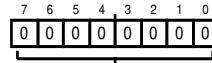

[7:0] FDSP\_SL\_P3[31:24] (R/W)  
FastDSP Safeload Parameter 3 (A1 Coefficient) Value to Be Written

Table 143. Bit Descriptions for FDSP\_SL\_P3\_3

Bits	Bit Name	Settings	Description	Reset	Access
[7:0]	FDSP_SL_P3[31:24]		FastDSP Safeload Parameter 3 (A1 Coefficient) Value to Be Written	0x0	R/W

Address: 0xC078, Reset: 0x00, Name: FDSP\_SL\_P3\_2

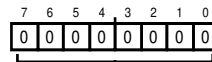

[7:0] FDSP\_SL\_P3[23:16] (R/W)  
FastDSP Safeload Parameter 3 (A1 Coefficient) Value to Be Written

Table 144. Bit Descriptions for FDSP\_SL\_P3\_2

Bits	Bit Name	Settings	Description	Reset	Access
[7:0]	FDSP_SL_P3[23:16]		FastDSP Safeload Parameter 3 (A1 Coefficient) Value to Be Written	0x0	R/W

Address: 0xC079, Reset: 0x00, Name: FDSP\_SL\_P3\_1

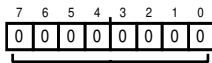

[7:0] FDSP\_SL\_P3[15:8] (R/W)  
FastDSP Safeload Parameter 3 (A1 Coefficient) Value to Be Written

Table 145. Bit Descriptions for FDSP\_SL\_P3\_1

Bits	Bit Name	Settings	Description	Reset	Access
[7:0]	FDSP_SL_P3[15:8]		FastDSP Safeload Parameter 3 (A1 Coefficient) Value to Be Written	0x0	R/W

Address: 0xC07A, Reset: 0x00, Name: FDSP\_SL\_P3\_0

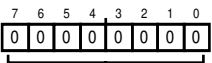

[7:0] FDSP\_SL\_P3[7:0] (R/W)  
FastDSP Safeload Parameter 3 (A1 Coefficient) Value to Be Written

Table 146. Bit Descriptions for FDSP\_SL\_P3\_0

Bits	Bit Name	Settings	Description	Reset	Access
[7:0]	FDSP_SL_P3[7:0]		FastDSP Safeload Parameter 3 (A1 Coefficient) Value to Be Written	0x0	R/W

**FastDSP SAFELoad PARAMETER 4 VALUE REGISTERS**

Address: 0xC07B, Reset: 0x00, Name: FDSP\_SL\_P4\_3

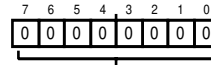

[7:0] FDSP\_SL\_P4[31:24] (R/W)  
FastDSP Safeload Parameter 4 (A2 Coefficient) Value to Be Written

Table 147. Bit Descriptions for FDSP\_SL\_P4\_3

Bits	Bit Name	Settings	Description	Reset	Access
[7:0]	FDSP_SL_P4[31:24]		FastDSP Safeload Parameter 4 (A2 Coefficient) Value to Be Written	0x0	R/W

Address: 0xC07C, Reset: 0x00, Name: FDSP\_SL\_P4\_2

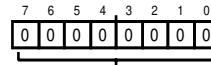

[7:0] FDSP\_SL\_P4[23:16] (R/W)  
FastDSP Safeload Parameter 4 (A2 Coefficient) Value to Be Written

Table 148. Bit Descriptions for FDSP\_SL\_P4\_2

Bits	Bit Name	Settings	Description	Reset	Access
[7:0]	FDSP_SL_P4[23:16]		FastDSP Safeload Parameter 4 (A2 Coefficient) Value to Be Written	0x0	R/W

Address: 0xC07D, Reset: 0x00, Name: FDSP\_SL\_P4\_1

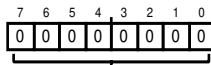

[7:0] FDSP\_SL\_P4[15:8] (R/W)  
FastDSP Safeload Parameter 4 (A2 Coefficient) Value to Be Written

Table 149. Bit Descriptions for FDSP\_SL\_P4\_1

Bits	Bit Name	Settings	Description	Reset	Access
[7:0]	FDSP_SL_P4[15:8]		FastDSP Safeload Parameter 4 (A2 Coefficient) Value to Be Written	0x0	R/W

Address: 0xC07E, Reset: 0x00, Name: FDSP\_SL\_P4\_0

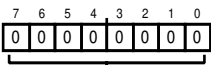

[7:0] FDSP\_SL\_P4[7:0] (R/W)  
FastDSP Safeload Parameter 4 (A2 Coefficient) Value to Be Written

Table 150. Bit Descriptions for FDSP\_SL\_P4\_0

Bits	Bit Name	Settings	Description	Reset	Access
[7:0]	FDSP_SL_P4[7:0]		FastDSP Safeload Parameter 4 (A2 Coefficient) Value to Be Written	0x0	R/W



### FastDSP SAFELOAD UPDATE REGISTER

Address: 0xC07F, Reset: 0x00, Name: FDSP\_SL\_UPDATE

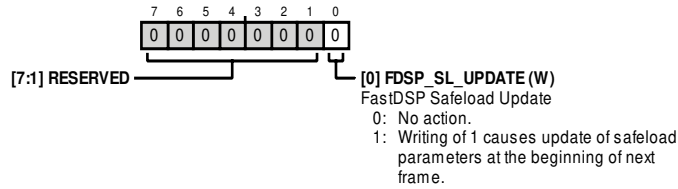

Table 151. Bit Descriptions for FDSP\_SL\_UPDATE

Bits	Bit Name	Settings	Description	Reset	Access
[7:1]	RESERVED		Reserved.	0x0	R
0	FDSP_SL_UPDATE	0 1	FastDSP Safeload Update. Writing a 1 to this register writes the parameter values in the FDSP_SL_Px registers to the addresses in the current bank associated with the instruction number in the FDSP_SL_ADDR register at the beginning of the next frame. No action. Writing of 1 causes update of safeload parameters at the beginning of next frame.	0x0	W

### SigmaDSP FRAME RATE SOURCE SELECT REGISTER

Address: 0xC080, Reset: 0x00, Name: SDSP\_CTRL1

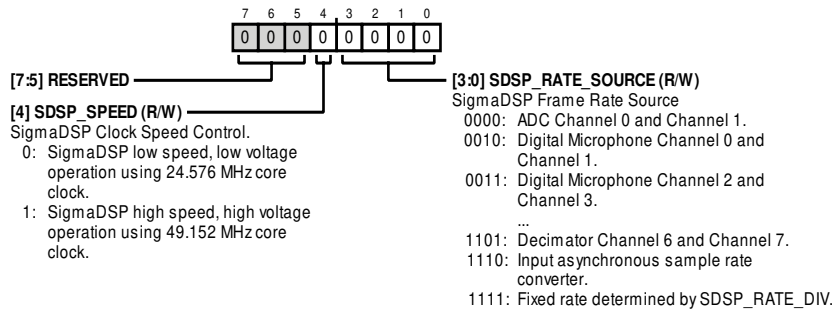

Table 152. Bit Descriptions for SDSP\_CTRL1

Bits	Bit Name	Settings	Description	Reset	Access
[7:5]	RESERVED		Reserved.	0x0	R
4	SDSP_SPEED	0 1	SigmaDSP Clock Speed Control. SigmaDSP low speed, low voltage operation using 24.576 MHz core clock. SigmaDSP high speed, high voltage operation using 49.152 MHz core clock.	0x0	R/W
[3:0]	SDSP_RATE_SOURCE	0000 0010 0011 0110 1010 1011 1100 1101 1110 1111	SigmaDSP Frame Rate Source. ADC Channel 0 and Channel 1. Digital Microphone Channel 0 and Channel 1. Digital Microphone Channel 2 and Channel 3. Serial Audio Interface 0. Decimator Channel 0 and Channel 1. Decimator Channel 2 and Channel 3. Decimator Channel 4 and Channel 5. Decimator Channel 6 and Channel 7. Input asynchronous sample rate converter. Fixed rate determined by SDSP_RATE_DIV.	0x0	R/W

### SigmaDSP RUN REGISTER

Address: 0xC081, Reset: 0x00, Name: SDSP\_CTRL2

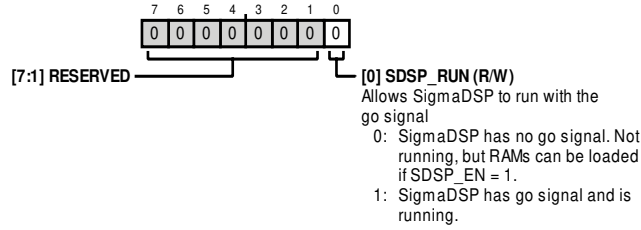

Table 153. Bit Descriptions for SDSP\_CTRL2

Bits	Bit Name	Settings	Description	Reset	Access
[7:1]	RESERVED		Reserved.	0x0	R
0	SDSP_RUN	0 1	Allows SigmaDSP to run with the go signal. SigmaDSP has no go signal. Not running, but RAMs can be loaded if SDSP_EN = 1. SigmaDSP has go signal and is running.	0x0	R/W

### SigmaDSP WATCHDOG CONTROLS REGISTER

Address: 0xC082, Reset: 0x00, Name: SDSP\_CTRL3

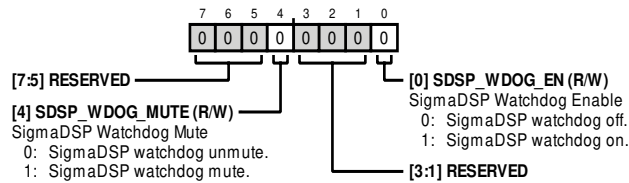

Table 154. Bit Descriptions for SDSP\_CTRL3

Bits	Bit Name	Settings	Description	Reset	Access
[7:5]	RESERVED		Reserved.	0x0	R
4	SDSP_WDOG_MUTE	0 1	SigmaDSP Watchdog Mute. SigmaDSP watchdog unmute. SigmaDSP watchdog mute.	0x0	R/W
[3:1]	RESERVED		Reserved.	0x0	R
0	SDSP_WDOG_EN	0 1	SigmaDSP Watchdog Enable. SigmaDSP watchdog off. SigmaDSP watchdog on.	0x0	R/W

### SigmaDSP WATCHDOG VALUE REGISTERS

Address: 0xC083, Reset: 0x00, Name: SDSP\_CTRL4

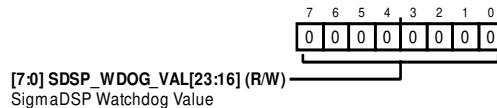

Table 155. Bit Descriptions for SDSP\_CTRL4

Bits	Bit Name	Settings	Description	Reset	Access
[7:0]	SDSP_WDOG_VAL[23:16]		SigmaDSP Watchdog Value	0x0	R/W

Address: 0xC084, Reset: 0x00, Name: SDSP\_CTRL5

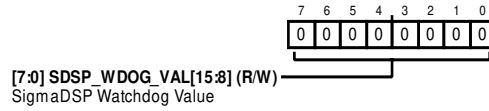

Table 156. Bit Descriptions for SDSP\_CTRL5

Bits	Bit Name	Settings	Description	Reset	Access
[7:0]	SDSP_WDOG_VAL[15:8]		SigmaDSP Watchdog Value	0x0	R/W

Address: 0xC085, Reset: 0x00, Name: SDSP\_CTRL6

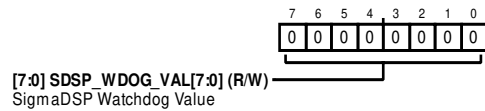

Table 157. Bit Descriptions for SDSP\_CTRL6

Bits	Bit Name	Settings	Description	Reset	Access
[7:0]	SDSP_WDOG_VAL[7:0]		SigmaDSP Watchdog Value	0x0	R/W

**SigmaDSP MODULO DATA MEMORY START POSITION REGISTERS**

Address: 0xC086, Reset: 0x07, Name: SDSP\_CTRL7

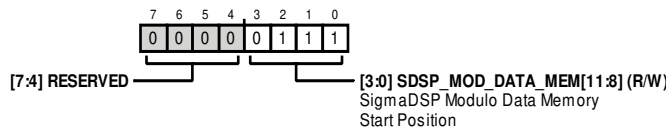

Table 158. Bit Descriptions for SDSP\_CTRL7

Bits	Bit Name	Settings	Description	Reset	Access
[7:4]	RESERVED		Reserved	0x0	R
[3:0]	SDSP_MOD_DATA_MEM[11:8]		SigmaDSP Modulo Data Memory Start Position	0x7	R/W

Address: 0xC087, Reset: 0xF4, Name: SDSP\_CTRL8

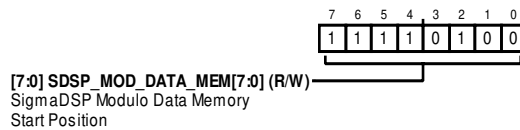
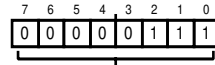

Table 159. Bit Descriptions for SDSP\_CTRL8

Bits	Bit Name	Settings	Description	Reset	Access
[7:0]	SDSP_MOD_DATA_MEM[7:0]		SigmaDSP Modulo Data Memory Start Position	0xF4	R/W

**SigmaDSP FIXED FRAME RATE DIVISOR REGISTERS**

Address: 0xC088, Reset: 0x07, Name: SDSP\_CTRL9



[7:0] SDSP\_RATE\_DIV[15:8] (R/W)  
SigmaDSP Go Signal Division. Number of 49.152 MHz clock cycles between go signal is SDSP\_RATE\_DIV plus 1 when SDSP\_RATE\_SOURCE set to fixed.

Table 160. Bit Descriptions for SDSP\_CTRL9

Bits	Bit Name	Settings	Description	Reset	Access
[7:0]	SDSP_RATE_DIV[15:8]		SigmaDSP Go Signal Division. Number of 49.152 MHz clock cycles between go signal is SDSP_RATE_DIV plus 1 when SDSP_RATE_SOURCE set to fixed.	0x7	R/W

Address: 0xC089, Reset: 0xFF, Name: SDSP\_CTRL10

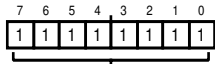

[7:0] SDSP\_RATE\_DIV[7:0] (R/W)  
SigmaDSP Go Signal Division. Number of 49.152 MHz clock cycles between go signal is SDSP\_RATE\_DIV plus 1 when SDSP\_RATE\_SOURCE set to fixed.

Table 161. Bit Descriptions for SDSP\_CTRL10

Bits	Bit Name	Settings	Description	Reset	Access
[7:0]	SDSP_RATE_DIV[7:0]		SigmaDSP Go Signal Division. Number of 49.152 MHz clock cycles between go signal is SDSP_RATE_DIV plus 1 when SDSP_RATE_SOURCE set to fixed.	0xFF	R/W

**SigmaDSP SET INTERRUPTS REGISTER**

Address: 0xC08A, Reset: 0x00, Name: SDSP\_CTRL11

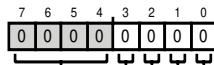

[7:4] RESERVED  
[3] SDSP\_INT3 (W)  
SigmaDSP Trigger Interrupt 3  
0: Writing of 0 has no effect.  
1: Writing of 1 triggers SigmaDSP interrupt.  
[2] SDSP\_INT2 (W)  
SigmaDSP Trigger Interrupt 2  
0: Writing of 0 has no effect.  
1: Writing of 1 triggers SigmaDSP interrupt.  
[1] SDSP\_INT1 (W)  
SigmaDSP Trigger Interrupt 1  
0: Writing of 0 has no effect.  
1: Writing of 1 triggers SigmaDSP interrupt.  
[0] SDSP\_INT0 (W)  
SigmaDSP Trigger Interrupt 0  
0: Writing of 0 has no effect.  
1: Writing of 1 triggers SigmaDSP interrupt.

Table 162. Bit Descriptions for SDSP\_CTRL11

Bits	Bit Name	Settings	Description	Reset	Access
[7:4]	RESERVED		Reserved.	0x0	R
3	SDSP_INT3		SigmaDSP Trigger Interrupt 3. 0 Writing of 0 has no effect. 1 Writing of 1 triggers SigmaDSP interrupt.	0x0	W
2	SDSP_INT2		SigmaDSP Trigger Interrupt 2. 0 Writing of 0 has no effect. 1 Writing of 1 triggers SigmaDSP interrupt.	0x0	W

Bits	Bit Name	Settings	Description	Reset	Access
1	SDSP_INT1	0 1	SigmaDSP Trigger Interrupt 1. Writing of 0 has no effect. Writing of 1 triggers SigmaDSP interrupt.	0x0	W
0	SDSP_INT0	0 1	SigmaDSP Trigger Interrupt 0. Writing of 0 has no effect. Writing of 1 triggers SigmaDSP interrupt.	0x0	W

**MULTIPURPOSE PIN 0/PIN 1 MODE SELECT REGISTER**

Address: 0xC08B, Reset: 0x00, Name: MP\_CTRL1

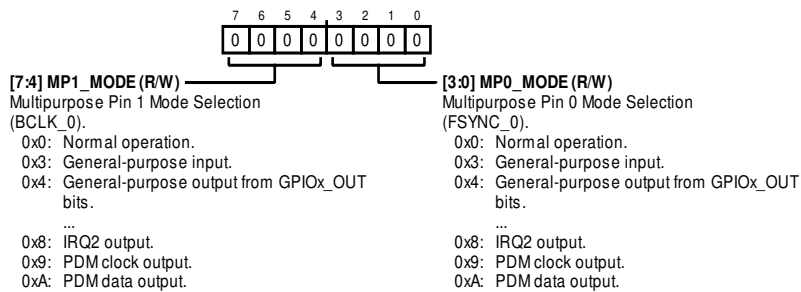
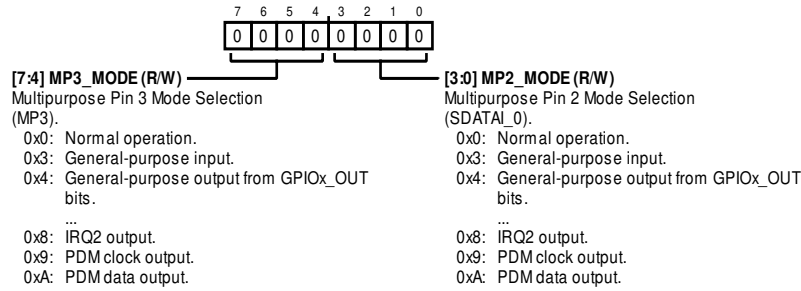

Table 163. Bit Descriptions for MP\_CTRL1

Bits	Bit Name	Settings	Description	Reset	Access
[7:4]	MP1_MODE	0x0 0x3 0x4 0x5 0x6 0x7 0x8 0x9 0xA	Multipurpose Pin 1 Mode Selection (BCLK_0). Normal operation. General-purpose input. General-purpose output from GPIOx_OUT bits. General-purpose output from SigmaDSP. Master clock output. IRQ1 output. IRQ2 output. PDM clock output. PDM data output.	0x0	R/W
[3:0]	MP0_MODE	0x0 0x3 0x4 0x5 0x6 0x7 0x8 0x9 0xA	Multipurpose Pin 0 Mode Selection (FSYNC_0). Normal operation. General-purpose input. General-purpose output from GPIOx_OUT bits. General-purpose output from SigmaDSP. Master clock output. IRQ1 output. IRQ2 output. PDM clock output. PDM data output.	0x0	R/W

**MULTIPURPOSE PIN 2/PIN 3 MODE SELECT REGISTER**

Address: 0xC08C, Reset: 0x00, Name: MP\_CTRL2

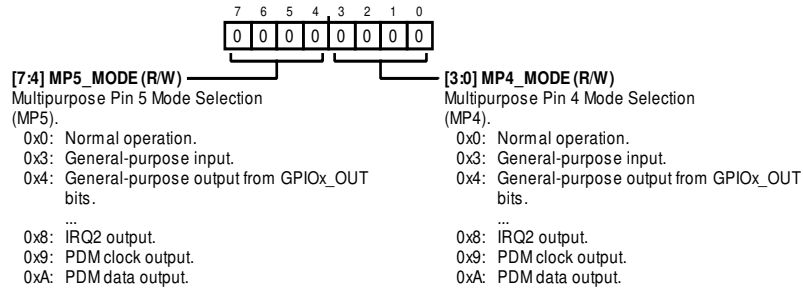

**Table 164. Bit Descriptions for MP\_CTRL2**

Bits	Bit Name	Settings	Description	Reset	Access
[7:4]	MP3_MODE	0x0 0x3 0x4 0x5 0x6 0x7 0x8 0x9 0xA	Multipurpose Pin 3 Mode Selection (MP3). Normal operation. General-purpose input. General-purpose output from GPIOx_OUT bits. General-purpose output from SigmaDSP. Master clock output. IRQ1 output. IRQ2 output. PDM clock output. PDM data output.	0x0	R/W
[3:0]	MP2_MODE	0x0 0x3 0x4 0x5 0x6 0x7 0x8 0x9 0xA	Multipurpose Pin 2 Mode Selection (SDATAI_0). Normal operation. General-purpose input. General-purpose output from GPIOx_OUT bits. General-purpose output from SigmaDSP. Master clock output. IRQ1 output. IRQ2 output. PDM clock output. PDM data output.	0x0	R/W

**MULTIPURPOSE PIN 4/PIN 5 MODE SELECT REGISTER**

Address: 0xC08D, Reset: 0x00, Name: MP\_CTRL3

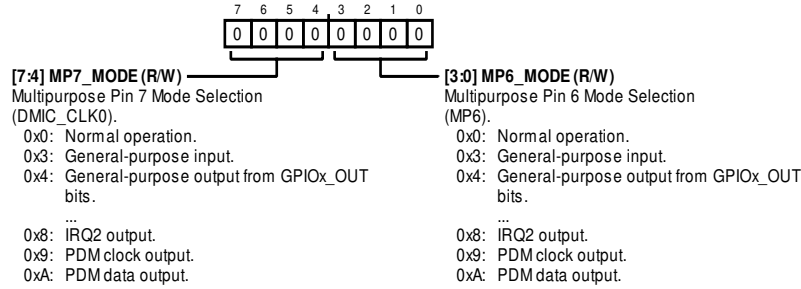

**Table 165. Bit Descriptions for MP\_CTRL3**

Bits	Bit Name	Settings	Description	Reset	Access
[7:4]	MP5_MODE	0x0 0x3 0x4 0x5 0x6 0x7 0x8 0x9 0xA	Multipurpose Pin 5 Mode Selection (MP5). Normal operation. General-purpose input. General-purpose output from GPIOx_OUT bits. General-purpose output from SigmaDSP. Master clock output. IRQ1 output. IRQ2 output. PDM clock output. PDM data output.	0x0	R/W
[3:0]	MP4_MODE	0x0 0x3 0x4 0x5 0x6 0x7 0x8 0x9 0xA	Multipurpose Pin 4 Mode Selection (MP4). Normal operation. General-purpose input. General-purpose output from GPIOx_OUT bits. General-purpose output from SigmaDSP. Master clock output. IRQ1 output. IRQ2 output. PDM clock output. PDM data output.	0x0	R/W

**MULTIPURPOSE PIN 6/PIN 7 MODE SELECT REGISTER**

Address: 0xC08E, Reset: 0x00, Name: MP\_CTRL4



**Table 166. Bit Descriptions for MP\_CTRL4**

Bits	Bit Name	Settings	Description	Reset	Access
[7:4]	MP7_MODE	0x0 0x3 0x4 0x5 0x6 0x7 0x8 0x9 0xA	Multipurpose Pin 7 Mode Selection (DMIC_CLK0). Normal operation. General-purpose input. General-purpose output from GPIOx_OUT bits. General-purpose output from SigmaDSP. Master clock output. IRQ1 output. IRQ2 output. PDM clock output. PDM data output.	0x0	R/W
[3:0]	MP6_MODE	0x0 0x3 0x4 0x5 0x6 0x7 0x8 0x9 0xA	Multipurpose Pin 6 Mode Selection (MP6). Normal operation. General-purpose input. General-purpose output from GPIOx_OUT bits. General-purpose output from SigmaDSP. Master clock output. IRQ1 output. IRQ2 output. PDM clock output. PDM data output.	0x0	R/W



**MULTIPURPOSE PIN 8/PIN 9 MODE SELECT REGISTER**

Address: 0xC08F, Reset: 0x00, Name: MP\_CTRL5

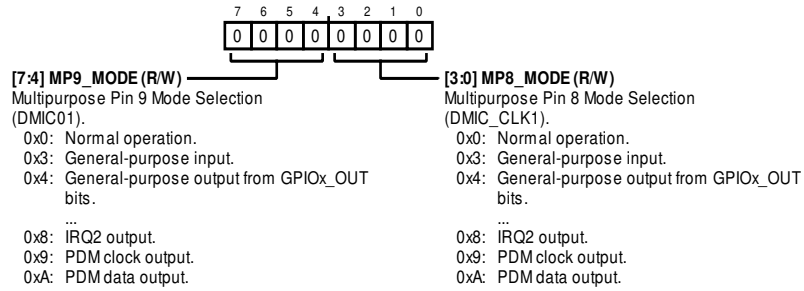

**Table 167. Bit Descriptions for MP\_CTRL5**

Bits	Bit Name	Settings	Description	Reset	Access
[7:4]	MP9_MODE	0x0 0x3 0x4 0x5 0x6 0x7 0x8 0x9 0xA	Multipurpose Pin 9 Mode Selection (DMIC01). Normal operation. General-purpose input. General-purpose output from GPIOx_OUT bits. General-purpose output from SigmaDSP. Master clock output. IRQ1 output. IRQ2 output. PDM clock output. PDM data output.	0x0	R/W
[3:0]	MP8_MODE	0x0 0x3 0x4 0x5 0x6 0x7 0x8 0x9 0xA	Multipurpose Pin 8 Mode Selection (DMIC_CLK1). Normal operation. General-purpose input. General-purpose output from GPIOx_OUT bits. General-purpose output from SigmaDSP. Master clock output. IRQ1 output. IRQ2 output. PDM clock output. PDM data output.	0x0	R/W

**MULTIPURPOSE PIN 10 MODE SELECT REGISTER**

Address: 0xC090, Reset: 0x00, Name: MP\_CTRL6

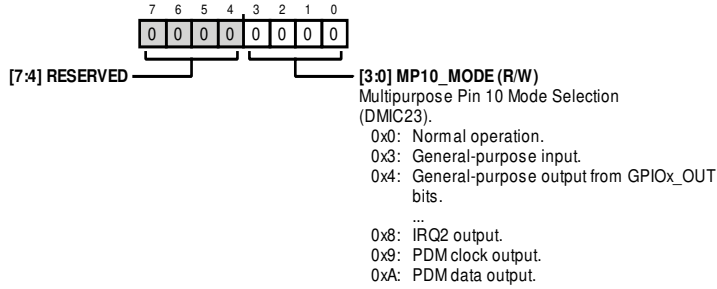

Table 168. Bit Descriptions for MP\_CTRL6

Bits	Bit Name	Settings	Description	Reset	Access
[7:4]	RESERVED		Reserved.	0x0	R/W
[3:0]	MP10_MODE	0x0 0x3 0x4 0x5 0x6 0x7 0x8 0x9 0xA	Multipurpose Pin 10 Mode Selection (DMIC23). Normal operation. General-purpose input. General-purpose output from GPIOx_OUT bits. General-purpose output from SigmaDSP. Master clock output. IRQ1 output. IRQ2 output. PDM clock output. PDM data output.	0x0	R/W

**GENERAL-PURPOSE INPUT DEBOUNCE CONTROL AND MASTER CLOCK OUTPUT RATE SELECTION REGISTER**

Address: 0xC091, Reset: 0x10, Name: MP\_CTRL7

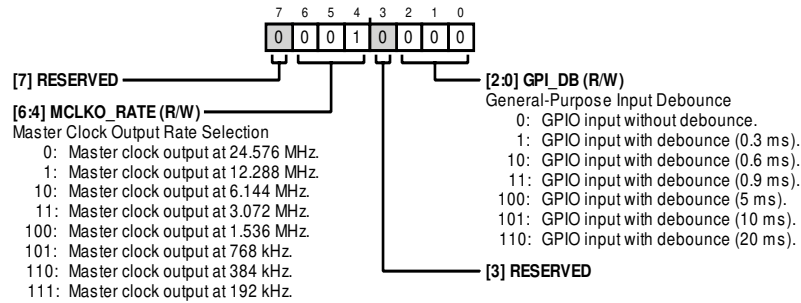

Table 169. Bit Descriptions for MP\_CTRL7

Bits	Bit Name	Settings	Description	Reset	Access
7	RESERVED		Reserved.	0x0	R
[6:4]	MCLKO_RATE	0 1 10 11 100 101 110 111	Master Clock Output Rate Selection. Master clock output at 24.576 MHz. Master clock output at 12.288 MHz. Master clock output at 6.144 MHz. Master clock output at 3.072 MHz. Master clock output at 1.536 MHz. Master clock output at 768 kHz. Master clock output at 384 kHz. Master clock output at 192 kHz.	0x1	R/W
3	RESERVED		Reserved.	0x0	R

Bits	Bit Name	Settings	Description	Reset	Access
[2:0]	GPI_DB		General-Purpose Input Debounce.	0x0	R/W
		0	GPIO input without debounce.		
		1	GPIO input with debounce (0.3 ms).		
		10	GPIO input with debounce (0.6 ms).		
		11	GPIO input with debounce (0.9 ms).		
		100	GPIO input with debounce (5 ms).		
		101	GPIO input with debounce (10 ms).		
		110	GPIO input with debounce (20 ms).		

**GENERAL-PURPOSE OUTPUTS CONTROL PIN 0 TO PIN 7 REGISTER**

Address: 0xC092, Reset: 0x00, Name: MP\_CTRL8

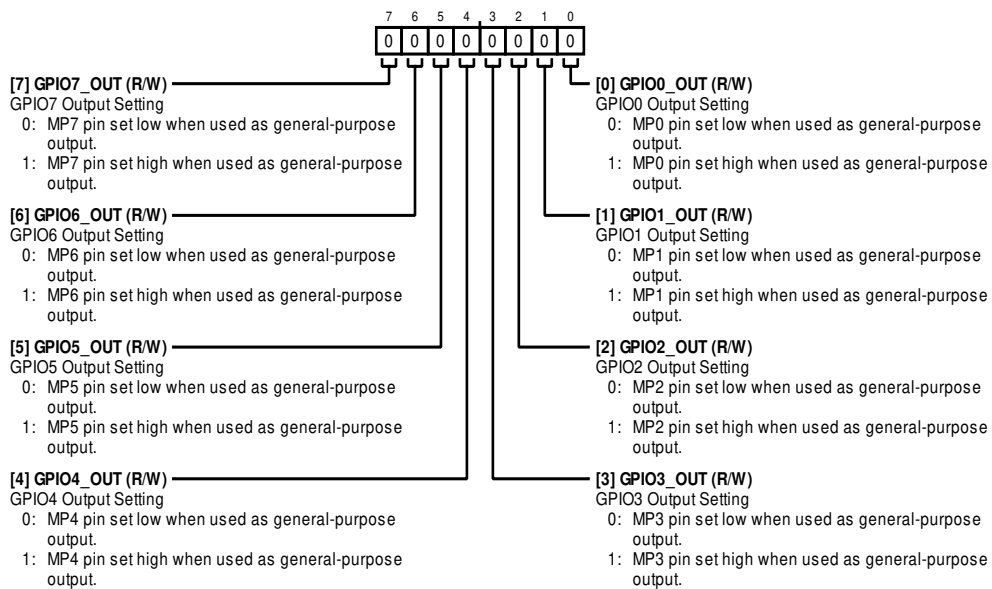

**Table 170. Bit Descriptions for MP\_CTRL8**

Bits	Bit Name	Settings	Description	Reset	Access
7	GPIO7_OUT		GPIO7 Output Setting.	0x0	R/W
		0	MP7 pin set low when used as general-purpose output.		
		1	MP7 pin set high when used as general-purpose output.		
6	GPIO6_OUT		GPIO6 Output Setting.	0x0	R/W
		0	MP6 pin set low when used as general-purpose output.		
		1	MP6 pin set high when used as general-purpose output.		
5	GPIO5_OUT		GPIO5 Output Setting.	0x0	R/W
		0	MP5 pin set low when used as general-purpose output.		
		1	MP5 pin set high when used as general-purpose output.		
4	GPIO4_OUT		GPIO4 Output Setting.	0x0	R/W
		0	MP4 pin set low when used as general-purpose output.		
		1	MP4 pin set high when used as general-purpose output.		
3	GPIO3_OUT		GPIO3 Output Setting.	0x0	R/W
		0	MP3 pin set low when used as general-purpose output.		
		1	MP3 pin set high when used as general-purpose output.		
2	GPIO2_OUT		GPIO2 Output Setting.	0x0	R/W
		0	MP2 pin set low when used as general-purpose output.		
		1	MP2 pin set high when used as general-purpose output.		

Bits	Bit Name	Settings	Description	Reset	Access
1	GPIO1_OUT		GPIO1 Output Setting.	0x0	R/W
		0	MP1 pin set low when used as general-purpose output.		
		1	MP1 pin set high when used as general-purpose output.		
0	GPIO0_OUT		GPIO0 Output Setting.	0x0	R/W
		0	MP0 pin set low when used as general-purpose output.		
		1	MP0 pin set high when used as general-purpose output.		

**GENERAL-PURPOSE OUTPUTS CONTROL PINS 8 TO PIN 10 REGISTER**

Address: 0xC093, Reset: 0x00, Name: MP\_CTRL9

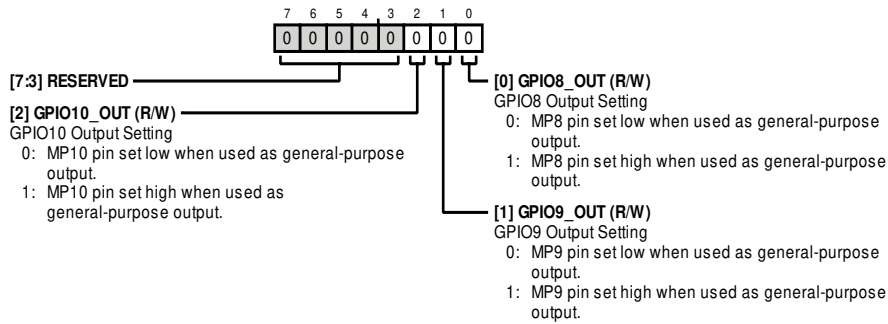
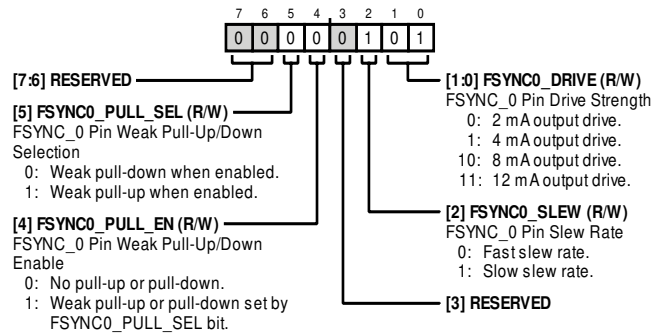

Table 171. Bit Descriptions for MP\_CTRL9

Bits	Bit Name	Settings	Description	Reset	Access
[7:3]	RESERVED		Reserved.	0x0	R
2	GPIO10_OUT		GPIO10 Output Setting.	0x0	R/W
		0	MP10 pin set low when used as general-purpose output.		
		1	MP10 pin set high when used as general-purpose output.		
1	GPIO9_OUT		GPIO9 Output Setting.	0x0	R/W
		0	MP9 pin set low when used as general-purpose output.		
		1	MP9 pin set high when used as general-purpose output.		
0	GPIO8_OUT		GPIO8 Output Setting.	0x0	R/W
		0	MP8 pin set low when used as general-purpose output.		
		1	MP8 pin set high when used as general-purpose output.		

**FSYNC\_0 PIN CONTROLS REGISTER**

Address: 0xC094, Reset: 0x05, Name: FSYNC0\_CTRL



**Table 172. Bit Descriptions for FSYNC0\_CTRL**

Bits	Bit Name	Settings	Description	Reset	Access
[7:6]	RESERVED		Reserved.	0x0	R
5	FSYNC0_PULL_SEL	0 1	FSYNC_0 Pin Weak Pull-Up/Down Selection. 0 Weak pull-down when enabled. 1 Weak pull-up when enabled.	0x0	R/W
4	FSYNC0_PULL_EN	0 1	FSYNC_0 Pin Weak Pull-Up/Down Enable. 0 No pull-up or pull-down. 1 Weak pull-up or pull-down set by FSYNC0_PULL_SEL bit.	0x0	R/W
3	RESERVED		Reserved.	0x0	R
2	FSYNC0_SLEW	0 1	FSYNC_0 Pin Slew Rate. Determines the slew rate of the pin when used as an output. 0 Fast slew rate. 1 Slow slew rate.	0x1	R/W
[1:0]	FSYNC0_DRIVE	0 1 10 11	FSYNC_0 Pin Drive Strength. Determines the drive strength of the pin when used as an output. 0 2 mA output drive. 1 4 mA output drive. 10 8 mA output drive. 11 12 mA output drive.	0x1	R/W

**BCLK\_0 PIN CONTROLS REGISTER**

Address: 0xC095, Reset: 0x05, Name: BCLK0\_CTRL

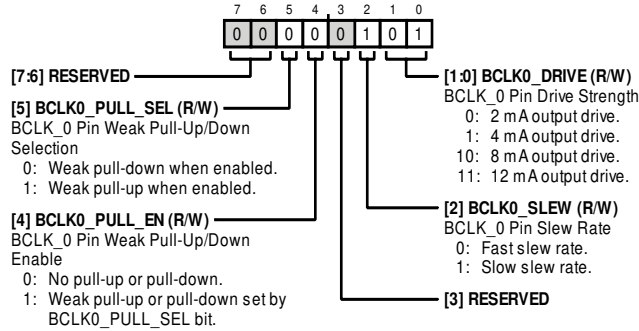

Table 173. Bit Descriptions for BCLK0\_CTRL

Bits	Bit Name	Settings	Description	Reset	Access
[7:6]	RESERVED		Reserved.	0x0	R
5	BCLK0_PULL_SEL	0 1	BCLK_0 Pin Weak Pull-Up/Down Selection. 0 Weak pull-down when enabled. 1 Weak pull-up when enabled.	0x0	R/W
4	BCLK0_PULL_EN	0 1	BCLK_0 Pin Weak Pull-Up/Down Enable. 0 No pull-up or pull-down. 1 Weak pull-up or pull-down set by BCLK0_PULL_SEL bit.	0x0	R/W
3	RESERVED		Reserved.	0x0	R
2	BCLK0_SLEW	0 1	BCLK_0 Pin Slew Rate. Determines the slew rate of the pin when used as an output. 0 Fast slew rate. 1 Slow slew rate.	0x1	R/W
[1:0]	BCLK0_DRIVE	0 1 10 11	BCLK_0 Pin Drive Strength. Determines the drive strength of the pin when used as an output. 0 2 mA output drive. 1 4 mA output drive. 10 8 mA output drive. 11 12 mA output drive.	0x1	R/W

**SDATA0\_0 PIN CONTROL REGISTER**

Address: 0xC096, Reset: 0x04, Name: SDATA00\_CTRL

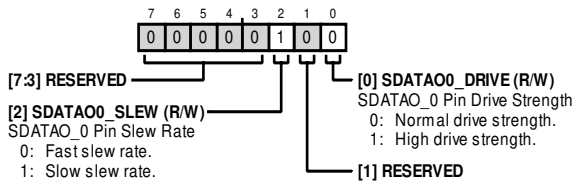

Table 174. Bit Descriptions for SDATA00\_CTRL

Bits	Bit Name	Settings	Description	Reset	Access
[7:3]	RESERVED		Reserved.	0x0	R
2	SDATA00_SLEW	0 1	SDATA0_0 Pin Slew Rate. Determines the slew rate of the pin when used as an output. 0 Fast slew rate. 1 Slow slew rate	0x1	R/W

Bits	Bit Name	Settings	Description	Reset	Access
1	RESERVED		Reserved.	0x0	R
0	SDATA00_DRIVE	0 1	SDATA0_0 drive strength. Normal drive strength. High drive strength.	0x0	R/W

### SDATAI\_0 PIN CONTROLS REGISTER

Address: 0xC097, Reset: 0x05, Name: SDATAI0\_CTRL

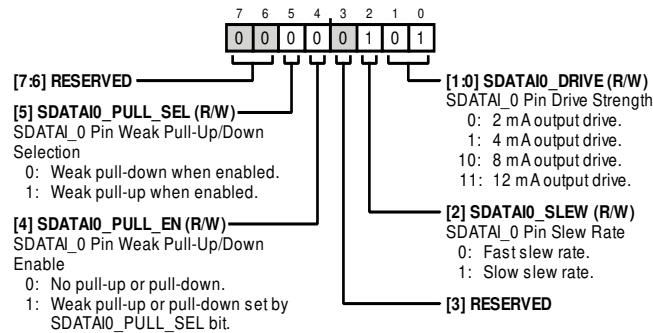
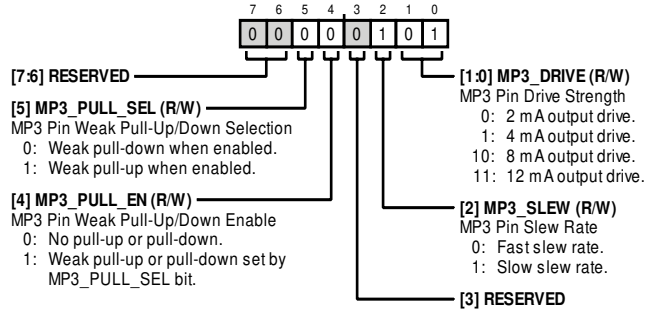

Table 175. Bit Descriptions for SDATAI0\_CTRL

Bits	Bit Name	Settings	Description	Reset	Access
[7:6]	RESERVED		Reserved.	0x0	R
5	SDATAI0_PULL_SEL	0 1	SDATAI_0 Pin Weak Pull-Up/Down Selection. Weak pull-down when enabled. Weak pull-up when enabled.	0x0	R/W
4	SDATAI0_PULL_EN	0 1	SDATAI_0 Pin Weak Pull-Up/Down Enable. No pull-up or pull-down. Weak pull-up or pull-down set by SDATAI0_PULL_SEL bit.	0x0	R/W
3	RESERVED		Reserved.	0x0	R
2	SDATAI0_SLEW	0 1	SDATAI_0 Pin Slew Rate. Determines the slew rate of the pin when used as an output. Fast slew rate. Slow slew rate.	0x1	R/W
[1:0]	SDATAI0_DRIVE	0 1 10 11	SDATAI_0 Pin Drive Strength. Determines the drive strength of the pin when used as an output. 2 mA output drive. 4 mA output drive. 8 mA output drive. 12 mA output drive.	0x1	R/W

**MP3 PIN CONTROLS REGISTER**

Address: 0xC098, Reset: 0x05, Name: MP3\_CTRL



**Table 176. Bit Descriptions for MP3\_CTRL**

Bits	Bit Name	Settings	Description	Reset	Access
[7:6]	RESERVED		Reserved.	0x0	R
5	MP3_PULL_SEL	0 1	MP3 Pin Weak Pull-Up/Down Selection. 0 Weak pull-down when enabled. 1 Weak pull-up when enabled.	0x0	R/W
4	MP3_PULL_EN	0 1	MP3 Pin Weak Pull-Up/Down Enable. 0 No pull-up or pull-down. 1 Weak pull-up or pull-down set by MP3_PULL_SEL bit.	0x0	R/W
3	RESERVED		Reserved.	0x0	R
2	MP3_SLEW	0 1	MP3 Pin Slew Rate. Determines the slew rate of the pin when used as an output. 0 Fast slew rate. 1 Slow slew rate.	0x1	R/W
[1:0]	MP3_DRIVE	0 1 10 11	MP3 Pin Drive Strength. Determines the drive strength of the pin when used as an output. 0 2 mA output drive. 1 4 mA output drive. 10 8 mA output drive. 11 12 mA output drive.	0x1	R/W



**MP4 PIN CONTROLS REGISTER**

Address: 0xC099, Reset: 0x05, Name: MP4\_CTRL

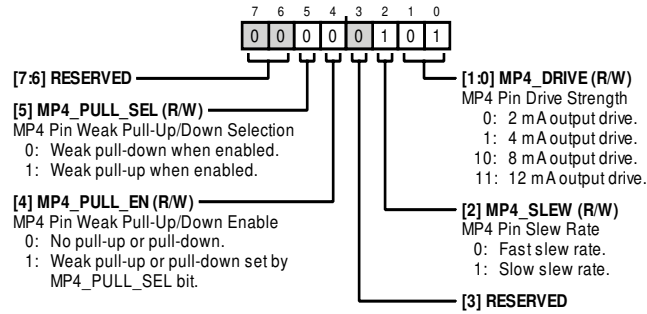
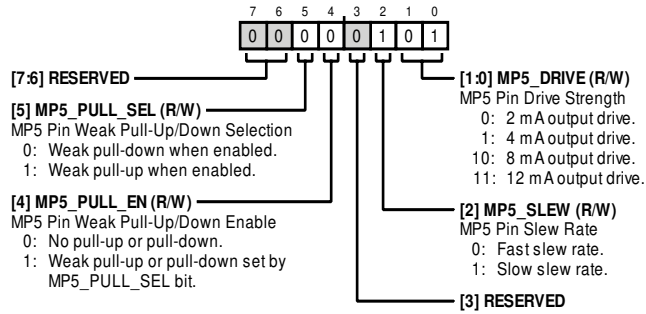

Table 177. Bit Descriptions for MP4\_CTRL

Bits	Bit Name	Settings	Description	Reset	Access
[7:6]	RESERVED		Reserved.	0x0	R
5	MP4_PULL_SEL	0 1	MP4 Pin Weak Pull-Up/Down Selection. Weak pull-down when enabled. Weak pull-up when enabled.	0x0	R/W
4	MP4_PULL_EN	0 1	MP4 Pin Weak Pull-Up/Down Enable. No pull-up or pull-down. Weak pull-up or pull-down set by MP4_PULL_SEL bit.	0x0	R/W
3	RESERVED		Reserved.	0x0	R
2	MP4_SLEW	0 1	MP4 Pin Slew Rate. Determines the slew rate of the pin when used as an output. Fast slew rate. Slow slew rate.	0x1	R/W
[1:0]	MP4_DRIVE	0 1 10 11	MP4 Pin Drive Strength. Determines the drive strength of the pin when used as an output. 2 mA output drive. 4 mA output drive. 8 mA output drive. 12 mA output drive.	0x1	R/W

**MP5 PIN CONTROLS REGISTER**

Address: 0xC09A, Reset: 0x05, Name: MP5\_CTRL



**Table 178. Bit Descriptions for MP5\_CTRL**

Bits	Bit Name	Settings	Description	Reset	Access
[7:6]	RESERVED		Reserved.	0x0	R
5	MP5_PULL_SEL	0 1	MP5 Pin Weak Pull-Up/Down Selection. 0 Weak pull-down when enabled. 1 Weak pull-up when enabled.	0x0	R/W
4	MP5_PULL_EN	0 1	MP5 Pin Weak Pull-Up/Down Enable. 0 No pull-up or pull-down. 1 Weak pull-up or pull-down set by MP5_PULL_SEL bit.	0x0	R/W
3	RESERVED		Reserved.	0x0	R
2	MP5_SLEW	0 1	MP5 Pin Slew Rate. Determines the slew rate of the pin when used as an output. 0 Fast slew rate. 1 Slow slew rate.	0x1	R/W
[1:0]	MP5_DRIVE	0 1 10 11	MP5 Pin Drive Strength. Determines the drive strength of the pin when used as an output. 0 2 mA output drive. 1 4 mA output drive. 10 8 mA output drive. 11 12 mA output drive.	0x1	R/W

**MP6 PIN CONTROLS REGISTER**

Address: 0xC09B, Reset: 0x05, Name: MP6\_CTRL

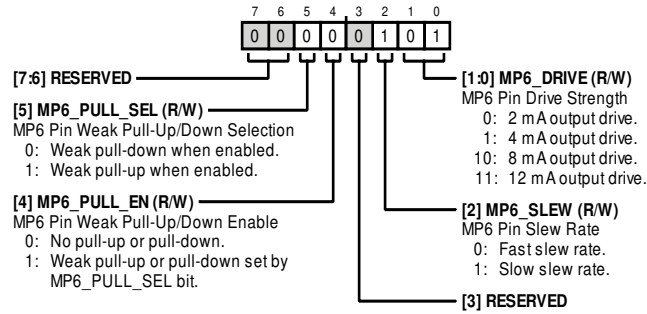
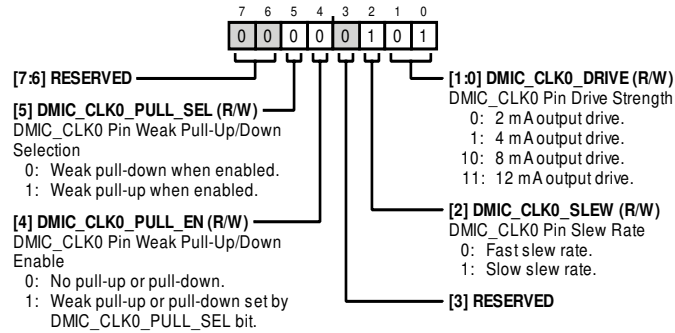

Table 179. Bit Descriptions for MP6\_CTRL

Bits	Bit Name	Settings	Description	Reset	Access
[7:6]	RESERVED		Reserved.	0x0	R
5	MP6_PULL_SEL	0 1	MP6 Pin Weak Pull-Up/Down Selection. Weak pull-down when enabled. Weak pull-up when enabled.	0x0	R/W
4	MP6_PULL_EN	0 1	MP6 Pin Weak Pull-Up/Down Enable. No pull-up or pull-down. Weak pull-up or pull-down set by MP6_PULL_SEL bit.	0x0	R/W
3	RESERVED		Reserved.	0x0	R
2	MP6_SLEW	0 1	MP6 Pin Slew Rate. Determines the slew rate of the pin when used as an output. Fast slew rate. Slow slew rate.	0x1	R/W
[1:0]	MP6_DRIVE	0 1 10 11	MP6 Pin Drive Strength. Determines the drive strength of the pin when used as an output. 2 mA output drive. 4 mA output drive. 8 mA output drive. 12 mA output drive.	0x1	R/W

**DMIC\_CLK0 PIN CONTROLS REGISTER**

Address: 0xC09C, Reset: 0x05, Name: DMIC\_CLK0\_CTRL

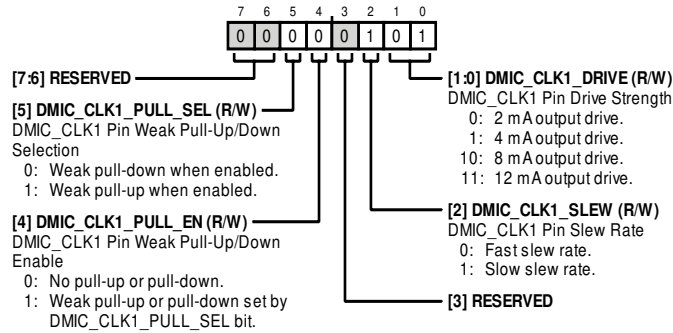

**Table 180. Bit Descriptions for DMIC\_CLK0\_CTRL**

Bits	Bit Name	Settings	Description	Reset	Access
[7:6]	RESERVED		Reserved.	0x0	R
5	DMIC_CLK0_PULL_SEL	0 1	DMIC_CLK0 Pin Weak Pull-Up/Down Selection. Weak pull-down when enabled. Weak pull-up when enabled.	0x0	R/W
4	DMIC_CLK0_PULL_EN	0 1	DMIC_CLK0 Pin Weak Pull-Up/Down Enable. No pull-up or pull-down. Weak pull-up or pull-down set by DMIC_CLK0_PULL_SEL bit.	0x0	R/W
3	RESERVED		Reserved.	0x0	R
2	DMIC_CLK0_SLEW	0 1	DMIC_CLK0 Pin Slew Rate. Determines the slew rate of the pin when used as an output. Fast slew rate. Slow slew rate.	0x1	R/W
[1:0]	DMIC_CLK0_DRIVE	0 1 10 11	DMIC_CLK0 Pin Drive Strength. Determines the drive strength of the pin when used as an output. 2 mA output drive. 4 mA output drive. 8 mA output drive. 12 mA output drive.	0x1	R/W

**DMIC\_CLK1 PIN CONTROLS REGISTER**

Address: 0xC09D, Reset: 0x05, Name: DMIC\_CLK1\_CTRL



**Table 181. Bit Descriptions for DMIC\_CLK1\_CTRL**

Bits	Bit Name	Settings	Description	Reset	Access
[7:6]	RESERVED		Reserved.	0x0	R
5	DMIC_CLK1_PULL_SEL	0 1	DMIC_CLK1 Pin Weak Pull-Up/Down Selection. 0 Weak pull-down when enabled. 1 Weak pull-up when enabled.	0x0	R/W
4	DMIC_CLK1_PULL_EN	0 1	DMIC_CLK1 Pin Weak Pull-Up/Down Enable. 0 No pull-up or pull-down. 1 Weak pull-up or pull-down set by DMIC_CLK1_PULL_SEL bit.	0x0	R/W
3	RESERVED		Reserved.	0x0	R
2	DMIC_CLK1_SLEW	0 1	DMIC_CLK1 Pin Slew Rate. Determines the slew rate of the pin when used as an output. 0 Fast slew rate. 1 Slow slew rate.	0x1	R/W
[1:0]	DMIC_CLK1_DRIVE	0 1 10 11	DMIC_CLK1 Pin Drive Strength. Determines the drive strength of the pin when used as an output. 0 2 mA output drive. 1 4 mA output drive. 10 8 mA output drive. 11 12 mA output drive.	0x1	R/W

**DMIC01 PIN CONTROLS REGISTER**

Address: 0xC09E, Reset: 0x05, Name: DMIC01\_CTRL

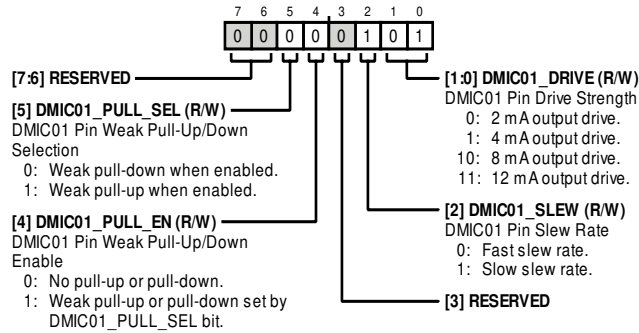

Table 182. Bit Descriptions for DMIC01\_CTRL

Bits	Bit Name	Settings	Description	Reset	Access
[7:6]	RESERVED		Reserved.	0x0	R
5	DMIC01_PULL_SEL	0 1	DMIC01 Pin Weak Pull-Up/Down Selection. 0 Weak pull-down when enabled. 1 Weak pull-up when enabled.	0x0	R/W
4	DMIC01_PULL_EN	0 1	DMIC01 Pin Weak Pull-Up/Down Enable. 0 No pull-up or pull-down. 1 Weak pull-up or pull-down set by DMIC01_PULL_SEL bit.	0x0	R/W
3	RESERVED		Reserved.	0x0	R
2	DMIC01_SLEW	0 1	DMIC01 Pin Slew Rate. Determines the slew rate of the pin when used as an output. 0 Fast slew rate. 1 Slow slew rate	0x1	R/W
[1:0]	DMIC01_DRIVE	0 1 10 11	DMIC01 Pin Drive Strength. Determines the drive strength of the pin when used as an output. 0 2 mA output drive. 1 4 mA output drive. 10 8 mA output drive. 11 12 mA output drive.	0x1	R/W

### DMIC23 PIN CONTROLS REGISTER

Address: 0xC09F, Reset: 0x05, Name: DMIC23\_CTRL

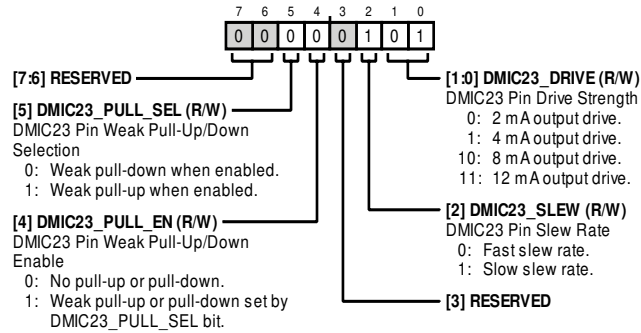

Table 183. Bit Descriptions for DMIC23\_CTRL

Bits	Bit Name	Settings	Description	Reset	Access
[7:6]	RESERVED		Reserved.	0x0	R
5	DMIC23_PULL_SEL	0 1	DMIC23 Pin Weak Pull-Up/Down Selection. 0 Weak pull-down when enabled. 1 Weak pull-up when enabled.	0x0	R/W
4	DMIC23_PULL_EN	0 1	DMIC23 Pin Weak Pull-Up/Down Enable. 0 No pull-up or pull-down. 1 Weak pull-up or pull-down set by DMIC23_PULL_SEL bit.	0x0	R/W
3	RESERVED		Reserved.	0x0	R
2	DMIC23_SLEW	0 1	DMIC23 Pin Slew Rate. Determines the slew rate of the pin when used as an output. 0 Fast slew rate. 1 Slow slew rate	0x1	R/W
[1:0]	DMIC23_DRIVE	0 1 10 11	DMIC23 Pin Drive Strength. Determines the drive strength of the pin when used as an output. 0 2 mA output drive. 1 4 mA output drive. 10 8 mA output drive. 11 12 mA output drive.	0x1	R/W

### SDA/MISO PIN CONTROLS REGISTER

Address: 0xC0A0, Reset: 0x00, Name: I2C\_SPI\_CTRL

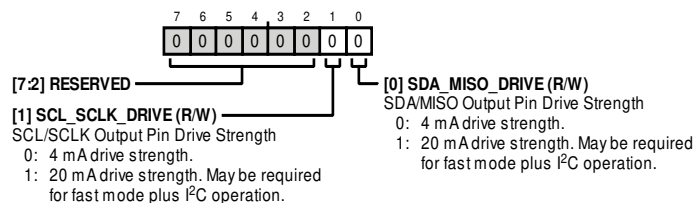

Table 184. Bit Descriptions for I2C\_SPI\_CTRL

Bits	Bit Name	Settings	Description	Reset	Access
[7:2]	RESERVED		Reserved.	0x0	R
1	SCL_SCLK_DRIVE	0 1	SCL/SCLK Output Pin Drive Strength. 0 4 mA drive strength. 1 20 mA drive strength. May be required for fast mode plus I <sup>2</sup> C operation.	0x0	R/W

Bits	Bit Name	Settings	Description	Reset	Access
0	SDA_MISO_DRIVE	0 1	SDA/MISO Output Pin Drive Strength. 4 mA drive strength. 20 mA drive strength. May be required for fast mode plus I <sup>2</sup> C operation.	0x0	R/W

**IRQ SIGNALING AND CLEARING REGISTER**

Address: 0xC0A1, Reset: 0x00, Name: IRQ\_CTRL1

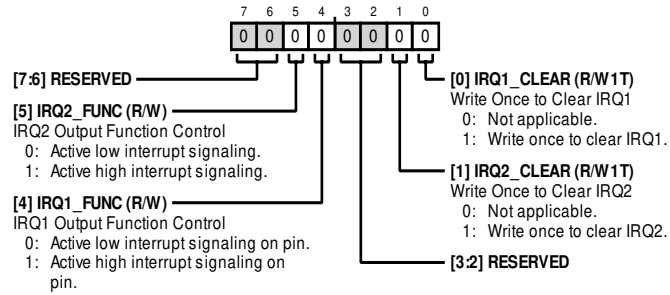

Table 185. Bit Descriptions for IRQ\_CTRL1

Bits	Bit Name	Settings	Description	Reset	Access
[7:6]	RESERVED		Reserved.	0x0	R
5	IRQ2_FUNC	0 1	IRQ2 Output Function Control. Active low interrupt signaling. Active high interrupt signaling.	0x0	R/W
4	IRQ1_FUNC	0 1	IRQ1 Output Function Control. Active low interrupt signaling on pin. Active high interrupt signaling on pin.	0x0	R/W
[3:2]	RESERVED		Reserved.	0x0	R
1	IRQ2_CLEAR	0 1	Write Once to Clear IRQ2. Not applicable. Write once to clear IRQ2.	0x0	R/W1T
0	IRQ1_CLEAR	0 1	Write Once to Clear IRQ1. Not applicable. Write once to clear IRQ1.	0x0	R/W1T



**IRQ1 MASKING REGISTERS**

Address: 0xC0A2, Reset: 0xF3, Name: IRQ1\_MASK1

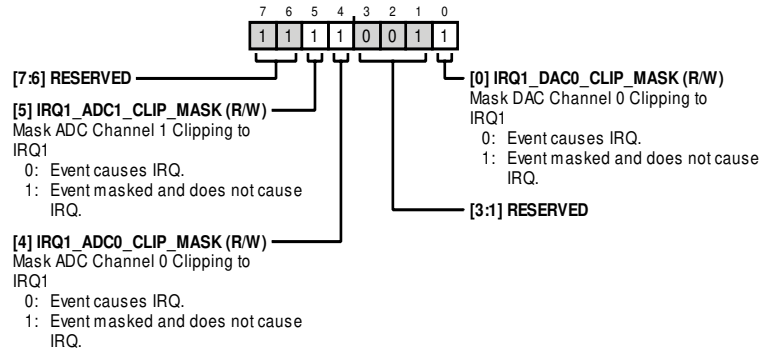

**Table 186. Bit Descriptions for IRQ1\_MASK1**

Bits	Bit Name	Settings	Description	Reset	Access
[7:6]	RESERVED		Reserved.	0x3	R/W
5	IRQ1_ADC1_CLIP_MASK	0 1	Mask ADC Channel 1 Clipping to IRQ1. 0 Event causes IRQ. 1 Event masked and does not cause IRQ.	0x1	R/W
4	IRQ1_ADC0_CLIP_MASK	0 1	Mask ADC Channel 0 Clipping to IRQ1. 0 Event causes IRQ. 1 Event masked and does not cause IRQ.	0x1	R/W
[3:1]	RESERVED		Reserved.	0x1	R
0	IRQ1_DAC0_CLIP_MASK	0 1	Mask DAC Channel 0 Clipping to IRQ1. 0 Event causes IRQ. 1 Event masked and does not cause IRQ.	0x1	R/W

Address: 0xC0A3, Reset: 0xFF, Name: IRQ1\_MASK2

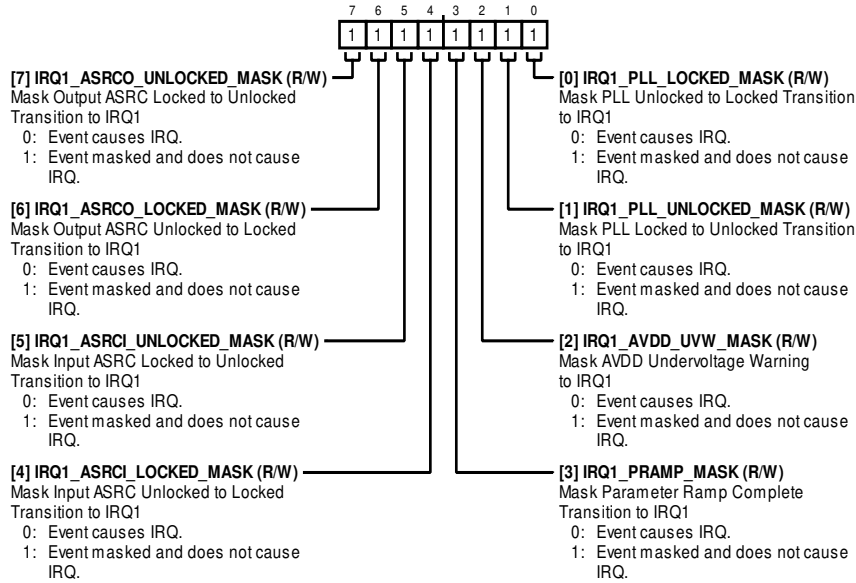

Table 187. Bit Descriptions for IRQ1\_MASK2

Bits	Bit Name	Settings	Description	Reset	Access
7	IRQ1_ASRCO_UNLOCKED_MASK	0 1	Mask Output ASRC Locked to Unlocked Transition to IRQ1. Event causes IRQ. Event masked and does not cause IRQ.	0x1	R/W
6	IRQ1_ASRCO_LOCKED_MASK	0 1	Mask Output ASRC Unlocked to Locked Transition to IRQ1. Event causes IRQ. Event masked and does not cause IRQ.	0x1	R/W
5	IRQ1_ASRCI_UNLOCKED_MASK	0 1	Mask Input ASRC Locked to Unlocked Transition to IRQ1. Event causes IRQ. Event masked and does not cause IRQ.	0x1	R/W
4	IRQ1_ASRCI_LOCKED_MASK	0 1	Mask Input ASRC Unlocked to Locked Transition to IRQ1. Event causes IRQ. Event masked and does not cause IRQ.	0x1	R/W
3	IRQ1_PRAMP_MASK	0 1	Mask Parameter Ramp Complete Transition to IRQ1. Event causes IRQ. Event masked and does not cause IRQ.	0x1	R/W
2	IRQ1_AVDD_UVW_MASK	0 1	Mask AVDD Undervoltage Warning to IRQ1. Event causes IRQ. Event masked and does not cause IRQ.	0x1	R/W
1	IRQ1_PLL_UNLOCKED_MASK	0 1	Mask PLL Locked to Unlocked Transition to IRQ1. Event causes IRQ. Event masked and does not cause IRQ.	0x1	R/W
0	IRQ1_PLL_LOCKED_MASK	0 1	Mask PLL Unlocked to Locked Transition to IRQ1. Event causes IRQ. Event masked and does not cause IRQ.	0x1	R/W

Address: 0xC0A4, Reset: 0x1F, Name: IRQ1\_MASK3

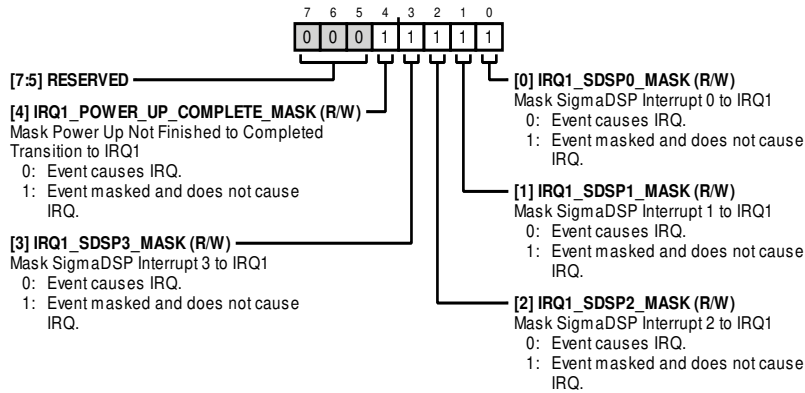
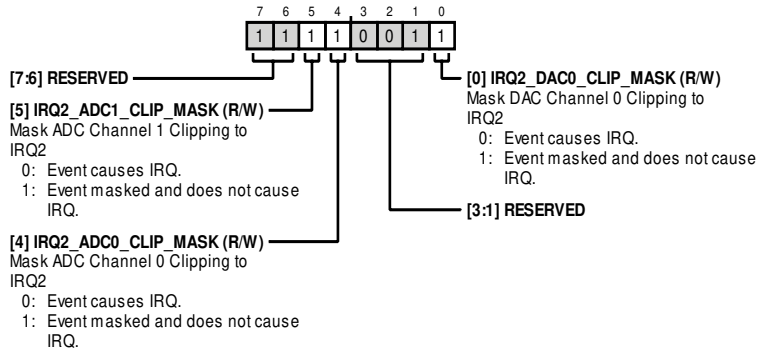

Table 188. Bit Descriptions for IRQ1\_MASK3

Bits	Bit Name	Settings	Description	Reset	Access
[7:5]	RESERVED		Reserved.	0x0	R
4	IRQ1_POWER_UP_COMPLETE_MASK	0 1	Mask Power Up Not Finished to Completed Transition to IRQ1. 0 Event causes IRQ. 1 Event masked and does not cause IRQ.	0x1	R/W
3	IRQ1_SDSP3_MASK	0 1	Mask SigmaDSP Interrupt 3 to IRQ1. 0 Event causes IRQ. 1 Event masked and does not cause IRQ.	0x1	R/W
2	IRQ1_SDSP2_MASK	0 1	Mask SigmaDSP Interrupt 2 to IRQ1. 0 Event causes IRQ. 1 Event masked and does not cause IRQ.	0x1	R/W
1	IRQ1_SDSP1_MASK	0 1	Mask SigmaDSP Interrupt 1 to IRQ1. 0 Event causes IRQ. 1 Event masked and does not cause IRQ.	0x1	R/W
0	IRQ1_SDSP0_MASK	0 1	Mask SigmaDSP Interrupt 0 to IRQ1. 0 Event causes IRQ. 1 Event masked and does not cause IRQ.	0x1	R/W

**IRQ2 MASKING REGISTERS**

Address: 0xC0A5, Reset: 0xF3, Name: IRQ2\_MASK1



**Table 189. Bit Descriptions for IRQ2\_MASK1**

Bits	Bit Name	Settings	Description	Reset	Access
[7:6]	RESERVED		Reserved.	0x3	R/W
5	IRQ2_ADC1_CLIP_MASK	0 1	Mask ADC Channel 1 Clipping to IRQ2. 0 Event causes IRQ. 1 Event masked and does not cause IRQ.	0x1	R/W
4	IRQ2_ADC0_CLIP_MASK	0 1	Mask ADC Channel 0 Clipping to IRQ2. 0 Event causes IRQ. 1 Event masked and does not cause IRQ.	0x1	R/W
[3:1]	RESERVED		Reserved.	0x1	R
0	IRQ2_DAC0_CLIP_MASK	0 1	Mask DAC Channel 0 Clipping to IRQ2. 0 Event causes IRQ. 1 Event masked and does not cause IRQ.	0x1	R/W

Address: 0xC0A6, Reset: 0xFF, Name: IRQ2\_MASK2

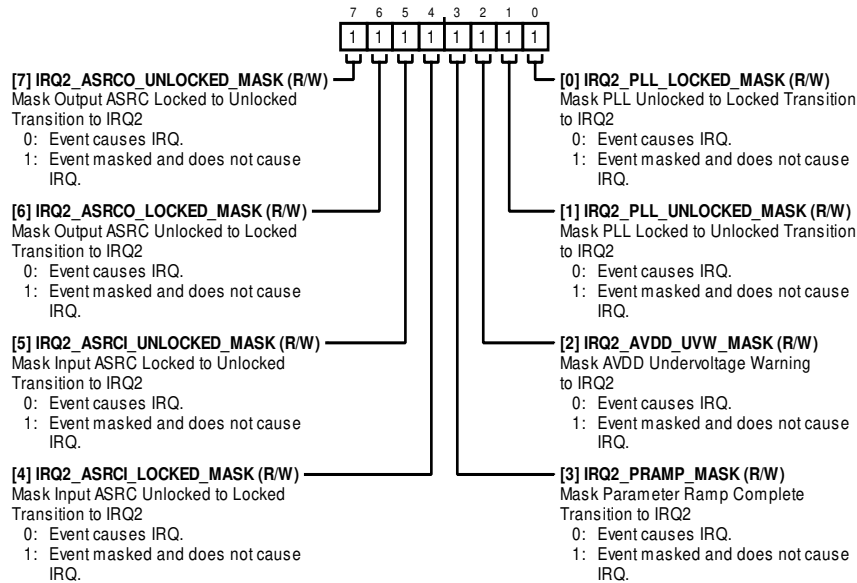

Table 190. Bit Descriptions for IRQ2\_MASK2

Bits	Bit Name	Settings	Description	Reset	Access
7	IRQ2_ASRCO_UNLOCKED_MASK	0 1	Mask Output ASRC Locked to Unlocked Transition to IRQ2. Event causes IRQ. Event masked and does not cause IRQ.	0x1	R/W
6	IRQ2_ASRCO_LOCKED_MASK	0 1	Mask Output ASRC Unlocked to Locked Transition to IRQ2. Event causes IRQ. Event masked and does not cause IRQ.	0x1	R/W
5	IRQ2_ASRCI_UNLOCKED_MASK	0 1	Mask Input ASRC Locked to Unlocked Transition to IRQ2. Event causes IRQ. Event masked and does not cause IRQ.	0x1	R/W
4	IRQ2_ASRCI_LOCKED_MASK	0 1	Mask Input ASRC Unlocked to Locked Transition to IRQ2. Event causes IRQ. Event masked and does not cause IRQ.	0x1	R/W
3	IRQ2_PRAMP_MASK	0 1	Mask Parameter Ramp Complete Transition to IRQ2. Event causes IRQ. Event masked and does not cause IRQ.	0x1	R/W
2	IRQ2_AVDD_UVW_MASK	0 1	Mask AVDD Undervoltage Warning to IRQ2. Event causes IRQ. Event masked and does not cause IRQ.	0x1	R/W
1	IRQ2_PLL_UNLOCKED_MASK	0 1	Mask PLL Locked to Unlocked Transition to IRQ2. Event causes IRQ. Event masked and does not cause IRQ.	0x1	R/W
0	IRQ2_PLL_LOCKED_MASK	0 1	Mask PLL Unlocked to Locked Transition to IRQ2. Event causes IRQ. Event masked and does not cause IRQ.	0x1	R/W

Address: 0xC0A7, Reset: 0x1F, Name: IRQ2\_MASK3

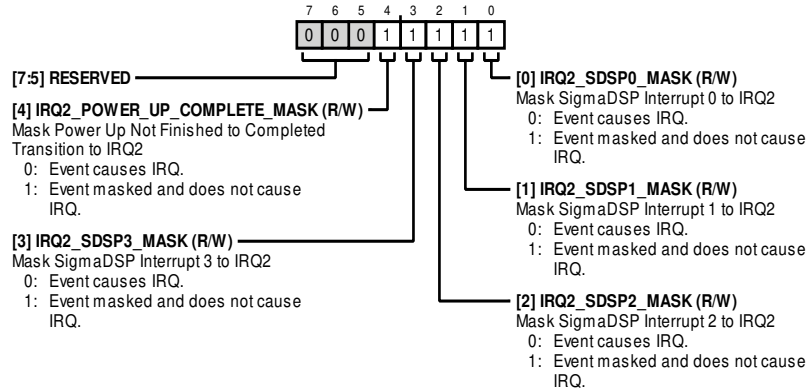

Table 191. Bit Descriptions for IRQ2\_MASK3

Bits	Bit Name	Settings	Description	Reset	Access
[7:5]	RESERVED		Reserved.	0x0	R
4	IRQ2_POWER_UP_COMPLETE_MASK	0 1	Mask Power Up Not Finished to Completed Transition to IRQ2. Event causes IRQ. Event masked and does not cause IRQ.	0x1	R/W
3	IRQ2_SDSP3_MASK	0 1	Mask SigmaDSP Interrupt 3 to IRQ2. Event causes IRQ. Event masked and does not cause IRQ.	0x1	R/W
2	IRQ2_SDSP2_MASK	0 1	Mask SigmaDSP Interrupt 2 to IRQ2. Event causes IRQ. Event masked and does not cause IRQ.	0x1	R/W
1	IRQ2_SDSP1_MASK	0 1	Mask SigmaDSP Interrupt 1 to IRQ2. Event causes IRQ. Event masked and does not cause IRQ.	0x1	R/W
0	IRQ2_SDSP0_MASK	0 1	Mask SigmaDSP Interrupt 0 to IRQ2. Event causes IRQ. Event masked and does not cause IRQ.	0x1	R/W

CHIP RESETS REGISTER

Address: 0xC0A8, Reset: 0x00, Name: RESETS

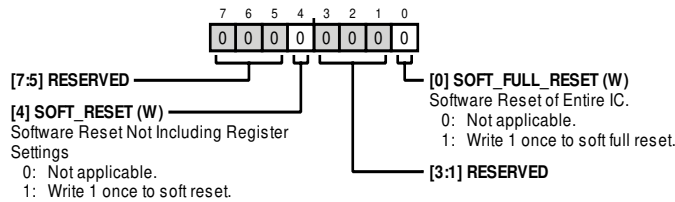

Table 192. Bit Descriptions for RESETS

Bits	Bit Name	Settings	Description	Reset	Access
[7:5]	RESERVED		Reserved.	0x0	R
4	SOFT_RESET	0 1	Software Reset Not Including Register Settings. Not applicable. Write 1 once to soft reset.	0x0	W

Bits	Bit Name	Settings	Description	Reset	Access
[3:1]	RESERVED		Reserved.	0x0	R
0	SOFT_FULL_RESET	0 1	Software Reset of Entire IC. Not applicable. Write 1 once to soft full reset.	0x0	W

**FastDSP CURRENT LAMBDA REGISTER**

Address: 0xC0A9, Reset: 0x3F, Name: READ\_LAMBDA

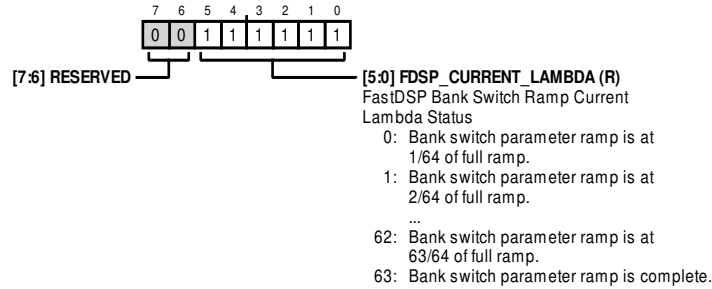

**Table 193. Bit Descriptions for READ\_LAMBDA**

Bits	Bit Name	Settings	Description	Reset	Access
[7:6]	RESERVED		Reserved.	0x0	R
[5:0]	FDSP_CURRENT_LAMBDA	0 1 ... 62 63	FastDSP Bank Switch Ramp Current Lambda Status. Lambda is a 6-bit value representing the point along the linear interpolation curve between two banks at which the bank ramp switch stops. Where A represents coefficient values in the source bank, and B represents coefficient values in the destination bank: $0 = ((63/64) \times A + (1/64) \times B)$ , $1 = ((62/64) \times A + (2/64) \times B)$ , ... , $62 = ((1/64) \times A + (63/64) \times B)$ , $63 = B$ (default). Lambda can be updated on the fly via the control interface. To complete a bank switch, a value of 63 (default setting) must be set. Actual current ramp point (FDSP_CURRENT_LAMBDA: 0 to 63) can be read via a status register. When this point reaches 63, the bank switch is complete, and the current parameters used match the current bank. Actual step size of linear interpolation is ~12-bits (4096 steps). Parameters in banks ramped between do not change during a bank switch. Bank switch parameter ramp is at 1/64 of full ramp. Bank switch parameter ramp is at 2/64 of full ramp. ... Bank switch parameter ramp is at 63/64 of full ramp. Bank switch parameter ramp is complete.	0x3F	R

**CHIP STATUS 1 REGISTER**

Address: 0xC0AA, Reset: 0x00, Name: STATUS1

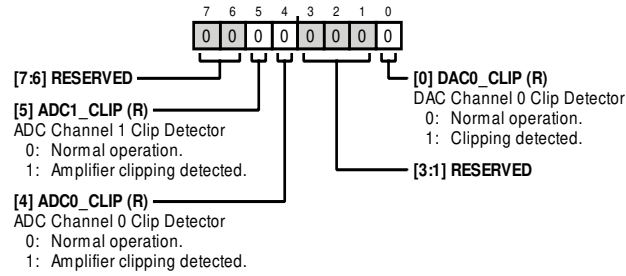

Table 194. Bit Descriptions for STATUS1

Bits	Bit Name	Settings	Description	Reset	Access
[7:6]	RESERVED		Reserved.	0x0	R
5	ADC1_CLIP	0 1	ADC Channel 1 Clip Detector. Normal operation. Amplifier clipping detected.	0x0	R
4	ADC0_CLIP	0 1	ADC Channel 0 Clip Detector. Normal operation. Amplifier clipping detected.	0x0	R
[3:1]	RESERVED		Reserved.	0x0	R
0	DAC0_CLIP	0 1	DAC Channel 0 Clip Detector. Normal operation. Clipping detected.	0x0	R

**CHIP STATUS 2 REGISTER**

Address: 0xC0AB, Reset: 0x00, Name: STATUS2

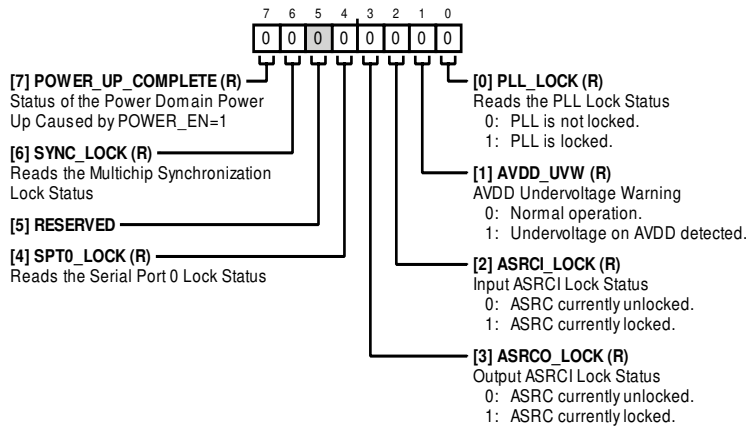

Table 195. Bit Descriptions for STATUS2

Bits	Bit Name	Settings	Description	Reset	Access
7	POWER_UP_COMPLETE		Status of the Power Domain Power Up Caused by POWER_EN = 1.	0x0	R
6	SYNC_LOCK		Reads the Multichip Synchronization Lock Status.	0x0	R
5	RESERVED		Reserved.	0x0	R
4	SPT0_LOCK		Reads the Serial Port 0 Lock Status.	0x0	R
3	ASRCO_LOCK	0 1	Output ASRCI Lock Status. ASRC currently unlocked. ASRC currently locked.	0x0	R



Bits	Bit Name	Settings	Description	Reset	Access
2	ASRCI_LOCK	0 1	Input ASRCI Lock Status. ASRC currently unlocked. ASRC currently locked.	0x0	R
1	AVDD_UVW	0 1	AVDD Undervoltage Warning. Normal operation. Undervoltage on AVDD detected.	0x0	R
0	PLL_LOCK	0 1	Reads the PLL Lock Status. PLL is not locked. PLL is locked.	0x0	R

**GENERAL-PURPOSE INPUT READ 0 TO INPUT READ 7 REGISTER**

Address: 0xC0AC, Reset: 0x00, Name: GPII

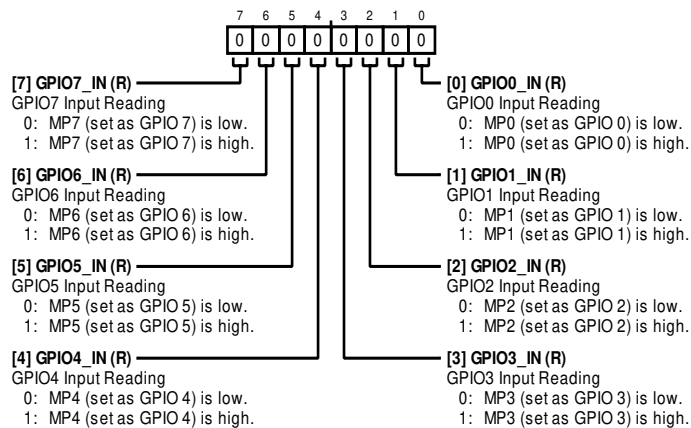

Table 196. Bit Descriptions for GPII

Bits	Bit Name	Settings	Description	Reset	Access
7	GPIO7_IN	0 1	GPIO7 Input Reading. MP7 (set as GPIO 7) is low. MP7 (set as GPIO 7) is high.	0x0	R
6	GPIO6_IN	0 1	GPIO6 Input Reading. MP6 (set as GPIO 6) is low. MP6 (set as GPIO 6) is high.	0x0	R
5	GPIO5_IN	0 1	GPIO5 Input Reading. MP5 (set as GPIO 5) is low. MP5 (set as GPIO 5) is high.	0x0	R
4	GPIO4_IN	0 1	GPIO4 Input Reading. MP4 (set as GPIO 4) is low. MP4 (set as GPIO 4) is high.	0x0	R
3	GPIO3_IN	0 1	GPIO3 Input Reading. MP3 (set as GPIO 3) is low. MP3 (set as GPIO 3) is high.	0x0	R
2	GPIO2_IN	0 1	GPIO2 Input Reading. MP2 (set as GPIO 2) is low. MP2 (set as GPIO 2) is high.	0x0	R

Bits	Bit Name	Settings	Description	Reset	Access
1	GPIO1_IN		GPIO1 Input Reading. 0 MP1 (set as GPIO 1) is low. 1 MP1 (set as GPIO 1) is high.	0x0	R
0	GPIO0_IN		GPIO0 Input Reading. 0 MP0 (set as GPIO 0) is low. 1 MP0 (set as GPIO 0) is high.	0x0	R

**GENERAL-PURPOSE INPUT READ 8 TO INPUT READ 10 REGISTER**

Address: 0xC0AD, Reset: 0x00, Name: GPI2

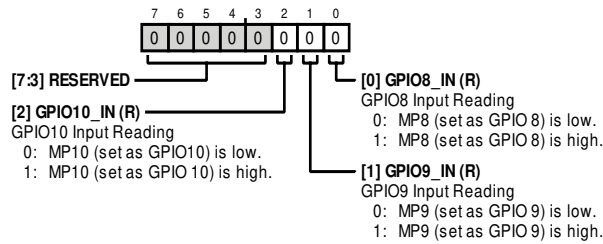

Table 197. Bit Descriptions for GPI2

Bits	Bit Name	Settings	Description	Reset	Access
[7:3]	RESERVED		Reserved.	0x0	R
2	GPIO10_IN		GPIO10 Input Reading. 0 MP10 (set as GPIO10) is low. 1 MP10 (set as GPIO 10) is high.	0x0	R
1	GPIO9_IN		GPIO9 Input Reading. 0 MP9 (set as GPIO 9) is low. 1 MP9 (set as GPIO 9) is high.	0x0	R
0	GPIO8_IN		GPIO8 Input Reading. 0 MP8 (set as GPIO 8) is low. 1 MP8 (set as GPIO 8) is high.	0x0	R

**DSP STATUS REGISTER**

Address: 0xC0AE, Reset: 0x00, Name: DSP\_STATUS

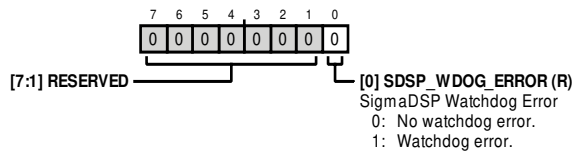

Table 198. Bit Descriptions for DSP\_STATUS

Bits	Bit Name	Settings	Description	Reset	Access
[7:1]	RESERVED		Reserved.	0x0	R
0	SDSP_WDOG_ERROR		SigmaDSP Watchdog Error. 0 No watchdog error. 1 Watchdog error.	0x0	R

**IRQ1 STATUS 1 REGISTER**

Address: 0xC0AF, Reset: 0x00, Name: IRQ1\_STATUS1

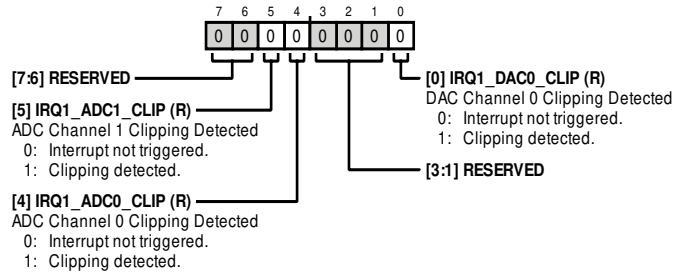
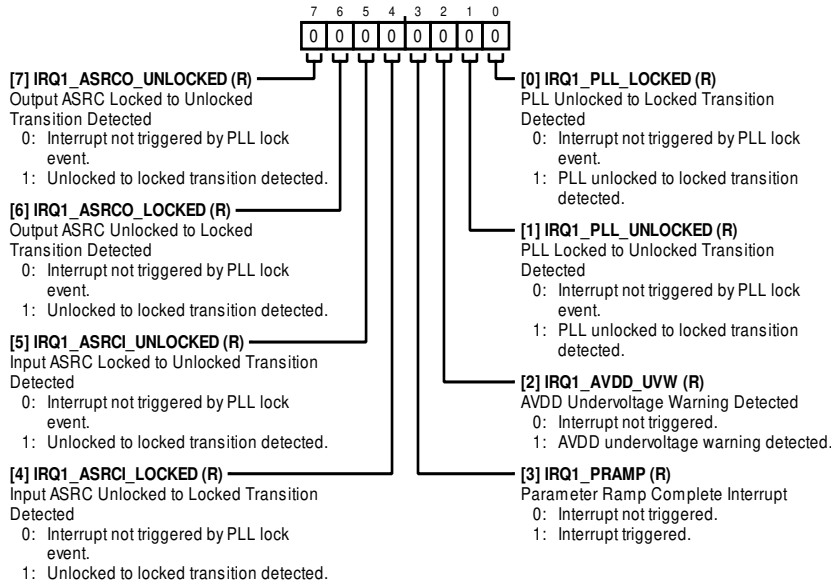

Table 199. Bit Descriptions for IRQ1\_STATUS1

Bits	Bit Name	Settings	Description	Reset	Access
[7:6]	RESERVED		Reserved.	0x0	R
5	IRQ1_ADC1_CLIP		ADC Channel 1 Clipping Detected. 0 Interrupt not triggered. 1 Clipping detected.	0x0	R
4	IRQ1_ADC0_CLIP		ADC Channel 0 Clipping Detected. 0 Interrupt not triggered. 1 Clipping detected.	0x0	R
[3:1]	RESERVED		Reserved.	0x0	R
0	IRQ1_DAC0_CLIP		DAC Channel 0 Clipping Detected. 0 Interrupt not triggered. 1 Clipping detected.	0x0	R

**IRQ1 STATUS 2 REGISTER**

Address: 0xC0B0, Reset: 0x00, Name: IRQ1\_STATUS2

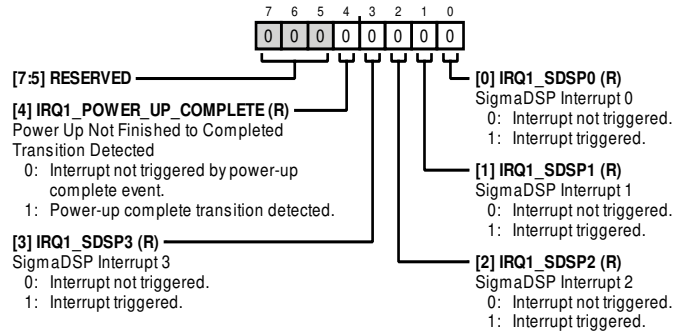

**Table 200. Bit Descriptions for IRQ1\_STATUS2**

Bits	Bit Name	Settings	Description	Reset	Access
7	IRQ1_ASRCO_UNLOCKED	0 1	Output ASRC Locked to Unlocked Transition Detected. Interrupt not triggered by PLL lock event. Unlocked to locked transition detected.	0x0	R
6	IRQ1_ASRCO_LOCKED	0 1	Output ASRC Unlocked to Locked Transition Detected. Interrupt not triggered by PLL lock event. Unlocked to locked transition detected.	0x0	R
5	IRQ1_ASRCI_UNLOCKED	0 1	Input ASRC Locked to Unlocked Transition Detected. Interrupt not triggered by PLL lock event. Unlocked to locked transition detected.	0x0	R
4	IRQ1_ASRCI_LOCKED	0 1	Input ASRC Unlocked to Locked Transition Detected. Interrupt not triggered by PLL lock event. Unlocked to locked transition detected.	0x0	R
3	IRQ1_PRAMP	0 1	Parameter Ramp Complete Interrupt. Interrupt not triggered. Interrupt triggered.	0x0	R
2	IRQ1_AVDD_UVW	0 1	AVDD Undervoltage Warning Detected. Interrupt not triggered. AVDD undervoltage warning detected.	0x0	R
1	IRQ1_PLL_UNLOCKED	0 1	PLL Locked to Unlocked Transition Detected. Interrupt not triggered by PLL lock event. PLL unlocked to locked transition detected.	0x0	R
0	IRQ1_PLL_LOCKED	0 1	PLL Unlocked to Locked Transition Detected. Interrupt not triggered by PLL lock event. PLL unlocked to locked transition detected.	0x0	R

**IRQ1 STATUS 3 REGISTER**

Address: 0xC0B1, Reset: 0x00, Name: IRQ1\_STATUS3



**Table 201. Bit Descriptions for IRQ1\_STATUS3**

Bits	Bit Name	Settings	Description	Reset	Access
[7:5]	RESERVED		Reserved.	0x0	R
4	IRQ1_POWER_UP_COMPLETE	0 1	Power Up Not Finished to Completed Transition Detected. Interrupt not triggered by power-up complete event. Power-up complete transition detected.	0x0	R
3	IRQ1_SDSP3	0 1	SigmaDSP Interrupt 3. Interrupt not triggered. Interrupt triggered.	0x0	R
2	IRQ1_SDSP2	0 1	SigmaDSP Interrupt 2. Interrupt not triggered. Interrupt triggered.	0x0	R
1	IRQ1_SDSP1	0 1	SigmaDSP Interrupt 1. Interrupt not triggered. Interrupt triggered.	0x0	R
0	IRQ1_SDSP0	0 1	SigmaDSP Interrupt 0. Interrupt not triggered. Interrupt triggered.	0x0	R

**IRQ2 STATUS 1 REGISTER**

Address: 0xC0B2, Reset: 0x00, Name: IRQ2\_STATUS1

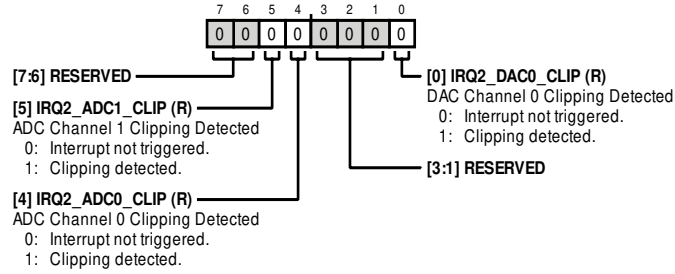

Table 202. Bit Descriptions for IRQ2\_STATUS1

Bits	Bit Name	Settings	Description	Reset	Access
[7:6]	RESERVED		Reserved.	0x0	R
5	IRQ2_ADC1_CLIP	0 1	ADC Channel 1 Clipping Detected. Interrupt not triggered. Clipping detected.	0x0	R
4	IRQ2_ADC0_CLIP	0 1	ADC Channel 0 Clipping Detected. Interrupt not triggered. Clipping detected.	0x0	R
[3:1]	RESERVED		Reserved.	0x0	R
0	IRQ2_DAC0_CLIP	0 1	DAC Channel 0 Clipping Detected. Interrupt not triggered. Clipping detected.	0x0	R

### IRQ2 STATUS 2 REGISTER

Address: 0xC0B3, Reset: 0x00, Name: IRQ2\_STATUS2

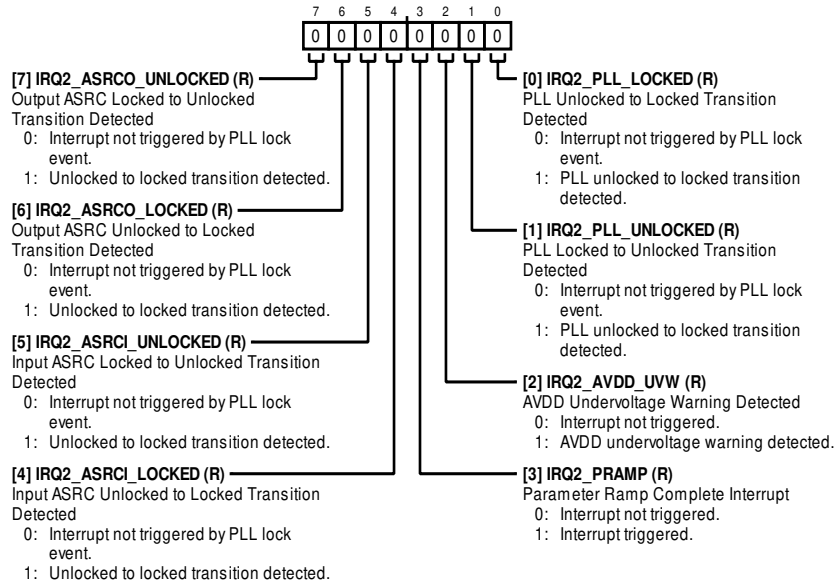

Table 203. Bit Descriptions for IRQ2\_STATUS2

Bits	Bit Name	Settings	Description	Reset	Access
7	IRQ2_ASRCO_UNLOCKED	0 1	Output ASRC Locked to Unlocked Transition Detected. Interrupt not triggered by PLL lock event. Unlocked to locked transition detected.	0x0	R
6	IRQ2_ASRCO_LOCKED	0 1	Output ASRC Unlocked to Locked Transition Detected. Interrupt not triggered by PLL lock event. Unlocked to locked transition detected.	0x0	R
5	IRQ2_ASRCI_UNLOCKED	0 1	Input ASRC Locked to Unlocked Transition Detected. Interrupt not triggered by PLL lock event. Unlocked to locked transition detected.	0x0	R
4	IRQ2_ASRCI_LOCKED	0 1	Input ASRC Unlocked to Locked Transition Detected. Interrupt not triggered by PLL lock event. Unlocked to locked transition detected.	0x0	R
3	IRQ2_PRAMP	0 1	Parameter Ramp Complete Interrupt. Interrupt not triggered. Interrupt triggered.	0x0	R
2	IRQ2_AVDD_UVW	0 1	AVDD Undervoltage Warning Detected. Interrupt not triggered. AVDD undervoltage warning detected.	0x0	R
1	IRQ2_PLL_UNLOCKED	0 1	PLL Locked to Unlocked Transition Detected. Interrupt not triggered by PLL lock event. PLL unlocked to locked transition detected.	0x0	R
0	IRQ2_PLL_LOCKED	0 1	PLL Unlocked to Locked Transition Detected. Interrupt not triggered by PLL lock event. PLL unlocked to locked transition detected.	0x0	R

**IRQ2 STATUS 3 REGISTER**

Address: 0xC0B4, Reset: 0x00, Name: IRQ2\_STATUS3

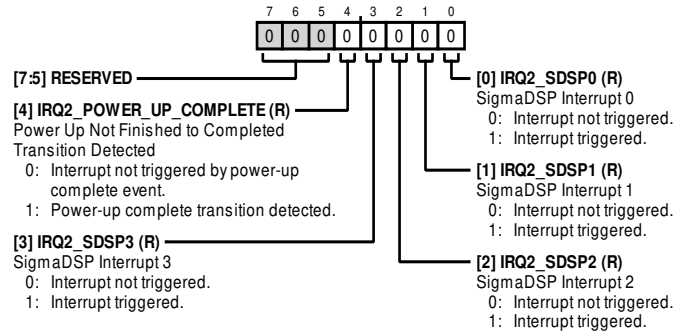

Table 204. Bit Descriptions for IRQ2\_STATUS3

Bits	Bit Name	Settings	Description	Reset	Access
[7:5]	RESERVED		Reserved.	0x0	R
4	IRQ2_POWER_UP_COMPLETE	0 1	Power Up Not Finished to Completed Transition Detected. Interrupt not triggered by power-up complete event. Power-up complete transition detected.	0x0	R
3	IRQ2_SDSP3	0 1	SigmaDSP Interrupt 3. Interrupt not triggered. Interrupt triggered.	0x0	R
2	IRQ2_SDSP2	0 1	SigmaDSP Interrupt 2. Interrupt not triggered. Interrupt triggered.	0x0	R
1	IRQ2_SDSP1	0 1	SigmaDSP Interrupt 1. Interrupt not triggered. Interrupt triggered.	0x0	R
0	IRQ2_SDSP0	0 1	SigmaDSP Interrupt 0. Interrupt not triggered. Interrupt triggered.	0x0	R



**SERIAL PORT 0 CONTROL 1 REGISTER**

Address: 0xC0B5, Reset: 0x00, Name: SPT0\_CTRL1

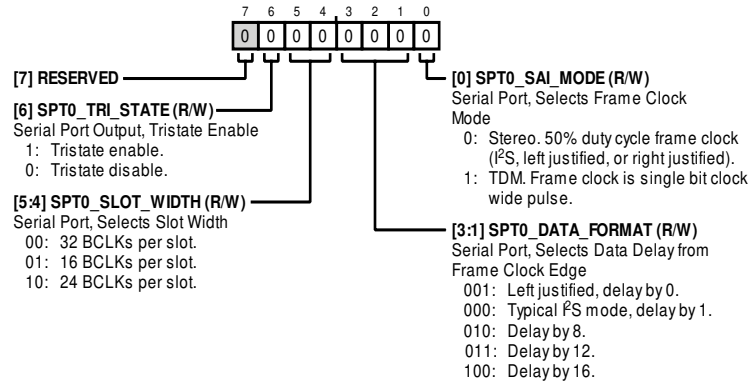

Table 205. Bit Descriptions for SPT0\_CTRL1

Bits	Bit Name	Settings	Description	Reset	Access
7	RESERVED		Reserved.	0x0	R/W
6	SPT0_TRI_STATE	1 0	Serial Port Output, Tristate Enable. Tristate enable. Tristate disable.	0x0	R/W
[5:4]	SPT0_SLOT_WIDTH	00 01 10	Serial Port, Selects Slot Width. 32 BCLKs per slot. 16 BCLKs per slot. 24 BCLKs per slot.	0x0	R/W
[3:1]	SPT0_DATA_FORMAT	001 000 010 011 100	Serial Port, Selects Data Delay from Frame Clock Edge. Left justified, delay by 0. Typical I <sup>2</sup> S mode, delay by 1. Delay by 8. Delay by 12. Delay by 16.	0x0	R/W
0	SPT0_SAI_MODE	0 1	Serial Port, Selects Frame Clock Mode. Stereo. 50% duty cycle frame clock (I <sup>2</sup> S, left justified, or right justified). TDM. Frame clock is single bit clock wide pulse.	0x0	R/W

**SERIAL PORT 0 CONTROL 2 REGISTER**

Address: 0xC0B6, Reset: 0x00, Name: SPT0\_CTRL2

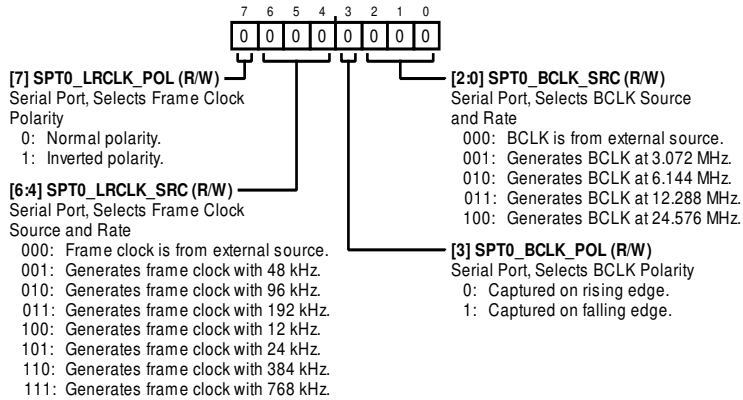
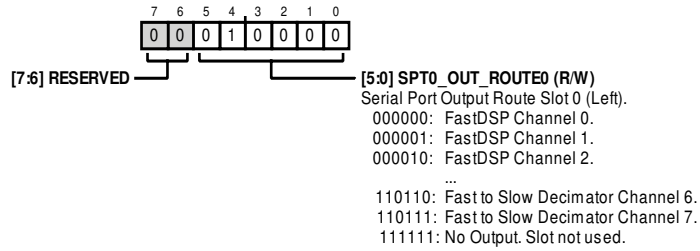

Table 206. Bit Descriptions for SPT0\_CTRL2

Bits	Bit Name	Settings	Description	Reset	Access
7	SPT0_LRCLK_POL	0 1	Serial Port, Selects Frame Clock Polarity. Normal polarity. Inverted polarity.	0x0	R/W
[6:4]	SPT0_LRCLK_SRC	000 001 010 011 100 101 110 111	Serial Port, Selects Frame Clock Source and Rate. Frame clock is from external source. Generates frame clock with 48 kHz. Generates frame clock with 96 kHz. Generates frame clock with 192 kHz. Generates frame clock with 12 kHz. Generates frame clock with 24 kHz. Generates frame clock with 384 kHz. Generates frame clock with 768 kHz.	0x0	R/W
3	SPT0_BCLK_POL	0 1	Serial Port, Selects BCLK Polarity. Captured on rising edge. Captured on falling edge.	0x0	R/W
[2:0]	SPT0_BCLK_SRC	000 001 010 011 100	Serial Port, Selects BCLK Source and Rate. BCLK is from external source. Generates BCLK at 3.072 MHz. Generates BCLK at 6.144 MHz. Generates BCLK at 12.288 MHz. Generates BCLK at 24.576 MHz.	0x0	R/W

**SERIAL PORT 0 OUTPUT ROUTING SLOT 0 (LEFT) REGISTER**

Address: 0xC0B7, Reset: 0x10, Name: SPT0\_ROUTE0



**Table 207. Bit Descriptions for SPT0\_ROUTE0**

Bits	Bit Name	Settings	Description	Reset	Access
[7:6]	RESERVED		Reserved.	0x0	R
[5:0]	SPT0_OUT_ROUTE0		Serial Port Output Route Slot 0 (Left).	0x10	R/W
		000000	FastDSP Channel 0.		
		000001	FastDSP Channel 1.		
		000010	FastDSP Channel 2.		
		000011	FastDSP Channel 3.		
		000100	FastDSP Channel 4.		
		000101	FastDSP Channel 5.		
		000110	FastDSP Channel 6.		
		000111	FastDSP Channel 7.		
		001000	FastDSP Channel 8.		
		001001	FastDSP Channel 9.		
		001010	FastDSP Channel 10.		
		001011	FastDSP Channel 11.		
		001100	FastDSP Channel 12.		
		001101	FastDSP Channel 13.		
		001110	FastDSP Channel 14.		
		001111	FastDSP Channel 15.		
		010000	SigmaDSP Channel 0.		
		010001	SigmaDSP Channel 1.		
		010010	SigmaDSP Channel 2.		
		010011	SigmaDSP Channel 3.		
		010100	SigmaDSP Channel 4.		
		010101	SigmaDSP Channel 5.		
		010110	SigmaDSP Channel 6.		
		010111	SigmaDSP Channel 7.		
		011000	SigmaDSP Channel 8.		
		011001	SigmaDSP Channel 9.		
		011010	SigmaDSP Channel 10.		
		011011	SigmaDSP Channel 11.		
		011100	SigmaDSP Channel 12.		
		011101	SigmaDSP Channel 13.		
		011110	SigmaDSP Channel 14.		
		011111	SigmaDSP Channel 15.		
		100000	Output ASRC Channel 0.		
		100001	Output ASRC Channel 1.		
		100010	Output ASRC Channel 2.		
		100011	Output ASRC Channel 3.		

Bits	Bit Name	Settings	Description	Reset	Access
		100100	ADC Channel 0.		
		100101	ADC Channel 1.		
		101000	Digital Microphone Channel 0.		
		101001	Digital Microphone Channel 1.		
		101010	Digital Microphone Channel 2.		
		101011	Digital Microphone Channel 3.		
		110000	Fast to Slow Decimator Channel 0.		
		110001	Fast to Slow Decimator Channel 1.		
		110010	Fast to Slow Decimator Channel 2.		
		110011	Fast to Slow Decimator Channel 3.		
		110100	Fast to Slow Decimator Channel 4.		
		110101	Fast to Slow Decimator Channel 5.		
		110110	Fast to Slow Decimator Channel 6.		
		110111	Fast to Slow Decimator Channel 7.		
		111111	No Output. Slot not used.		

**SERIAL PORT 0 OUTPUT ROUTING SLOT 1 (RIGHT) REGISTER**

Address: 0xC0B8, Reset: 0x11, Name: SPT0\_ROUTE1

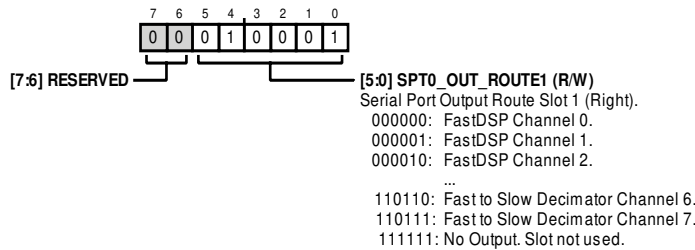

Table 208. Bit Descriptions for SPT0\_ROUTE1

Bits	Bit Name	Settings	Description	Reset	Access
[7:6]	RESERVED		Reserved.	0x0	R
[5:0]	SPT0_OUT_ROUTE1	000000 000001 000010 000011 000100 000101 000110 000111 001000 001001 001010 001011 001100 001101 001110 001111	Serial Port Output Route Slot 1 (Right). FastDSP Channel 0. FastDSP Channel 1. FastDSP Channel 2. FastDSP Channel 3. FastDSP Channel 4. FastDSP Channel 5. FastDSP Channel 6. FastDSP Channel 7. FastDSP Channel 8. FastDSP Channel 9. FastDSP Channel 10. FastDSP Channel 11. FastDSP Channel 12. FastDSP Channel 13. FastDSP Channel 14. FastDSP Channel 15.	0x11	R/W

Bits	Bit Name	Settings	Description	Reset	Access
		010000	SigmaDSP Channel 0.		
		010001	SigmaDSP Channel 1.		
		010010	SigmaDSP Channel 2.		
		010011	SigmaDSP Channel 3.		
		010100	SigmaDSP Channel 4.		
		010101	SigmaDSP Channel 5.		
		010110	SigmaDSP Channel 6.		
		010111	SigmaDSP Channel 7.		
		011000	SigmaDSP Channel 8.		
		011001	SigmaDSP Channel 9.		
		011010	SigmaDSP Channel 10.		
		011011	SigmaDSP Channel 11.		
		011100	SigmaDSP Channel 12.		
		011101	SigmaDSP Channel 13.		
		011110	SigmaDSP Channel 14.		
		011111	SigmaDSP Channel 15.		
		100000	Output ASRC Channel 0.		
		100001	Output ASRC Channel 1.		
		100010	Output ASRC Channel 2.		
		100011	Output ASRC Channel 3.		
		100100	ADC Channel 0.		
		100101	ADC Channel 1.		
		101000	Digital Microphone Channel 0.		
		101001	Digital Microphone Channel 1.		
		101010	Digital Microphone Channel 2.		
		101011	Digital Microphone Channel 3.		
		110000	Fast to Slow Decimator Channel 0.		
		110001	Fast to Slow Decimator Channel 1.		
		110010	Fast to Slow Decimator Channel 2.		
		110011	Fast to Slow Decimator Channel 3.		
		110100	Fast to Slow Decimator Channel 4.		
		110101	Fast to Slow Decimator Channel 5.		
		110110	Fast to Slow Decimator Channel 6.		
		110111	Fast to Slow Decimator Channel 7.		
		111111	No Output. Slot not used.		

**SERIAL PORT 0 OUTPUT ROUTING SLOT 2 REGISTER**

Address: 0xC0B9, Reset: 0x3F, Name: SPT0\_ROUTE2

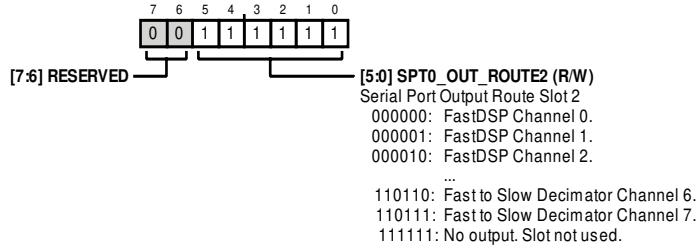

**Table 209. Bit Descriptions for SPT0\_ROUTE2**

Bits	Bit Name	Settings	Description	Reset	Access
[7:6]	RESERVED		Reserved.	0x0	R
[5:0]	SPT0_OUT_ROUTE2		Serial Port Output Route Slot 2	0x3F	R/W
		000000	FastDSP Channel 0.		
		000001	FastDSP Channel 1.		
		000010	FastDSP Channel 2.		
		000011	FastDSP Channel 3.		
		000100	FastDSP Channel 4.		
		000101	FastDSP Channel 5.		
		000110	FastDSP Channel 6.		
		000111	FastDSP Channel 7.		
		001000	FastDSP Channel 8.		
		001001	FastDSP Channel 9.		
		001010	FastDSP Channel 10.		
		001011	FastDSP Channel 11.		
		001100	FastDSP Channel 12.		
		001101	FastDSP Channel 13.		
		001110	FastDSP Channel 14.		
		001111	FastDSP Channel 15.		
		010000	SigmaDSP Channel 0.		
		010001	SigmaDSP Channel 1.		
		010010	SigmaDSP Channel 2.		
		010011	SigmaDSP Channel 3.		
		010100	SigmaDSP Channel 4.		
		010101	SigmaDSP Channel 5.		
		010110	SigmaDSP Channel 6.		
		010111	SigmaDSP Channel 7.		
		011000	SigmaDSP Channel 8.		
		011001	SigmaDSP Channel 9.		
		011010	SigmaDSP Channel 10.		
		011011	SigmaDSP Channel 11.		
		011100	SigmaDSP Channel 12.		
		011101	SigmaDSP Channel 13.		
		011110	SigmaDSP Channel 14.		
		011111	SigmaDSP Channel 15.		
		100000	Output ASRC Channel 0.		
		100001	Output ASRC Channel 1.		
		100010	Output ASRC Channel 2.		
		100011	Output ASRC Channel 3.		

Bits	Bit Name	Settings	Description	Reset	Access
		100100	ADC Channel 0.		
		100101	ADC Channel 1.		
		101000	Digital Microphone Channel 0.		
		101001	Digital Microphone Channel 1.		
		101010	Digital Microphone Channel 2.		
		101011	Digital Microphone Channel 3.		
		110000	Fast to Slow Decimator Channel 0.		
		110001	Fast to Slow Decimator Channel 1.		
		110010	Fast to Slow Decimator Channel 2.		
		110011	Fast to Slow Decimator Channel 3.		
		110100	Fast to Slow Decimator Channel 4.		
		110101	Fast to Slow Decimator Channel 5.		
		110110	Fast to Slow Decimator Channel 6.		
		110111	Fast to Slow Decimator Channel 7.		
		111111	No output. Slot not used.		

**SERIAL PORT 0 OUTPUT ROUTING SLOT 3 REGISTER**

Address: 0xC0BA, Reset: 0x3F, Name: SPT0\_ROUTE3

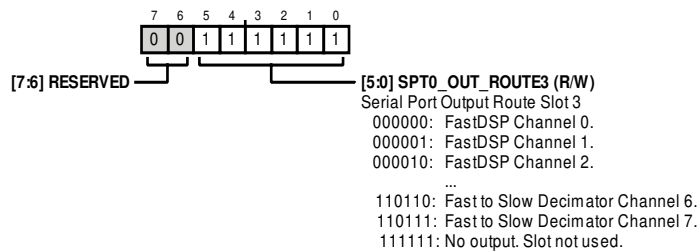

Table 210. Bit Descriptions for SPT0\_ROUTE3

Bits	Bit Name	Settings	Description	Reset	Access
[7:6]	RESERVED		Reserved.	0x0	R
[5:0]	SPT0_OUT_ROUTE3	000000	FastDSP Channel 0.	0x3F	R/W
		000001	FastDSP Channel 1.		
		000010	FastDSP Channel 2.		
		000011	FastDSP Channel 3.		
		000100	FastDSP Channel 4.		
		000101	FastDSP Channel 5.		
		000110	FastDSP Channel 6.		
		000111	FastDSP Channel 7.		
		001000	FastDSP Channel 8.		
		001001	FastDSP Channel 9.		
		001010	FastDSP Channel 10.		
		001011	FastDSP Channel 11.		
		001100	FastDSP Channel 12.		
		001101	FastDSP Channel 13.		
		001110	FastDSP Channel 14.		
		001111	FastDSP Channel 15.		

<b>Bits</b>	<b>Bit Name</b>	<b>Settings</b>	<b>Description</b>	<b>Reset</b>	<b>Access</b>
		010000	SigmaDSP Channel 0.		
		010001	SigmaDSP Channel 1.		
		010010	SigmaDSP Channel 2.		
		010011	SigmaDSP Channel 3.		
		010100	SigmaDSP Channel 4.		
		010101	SigmaDSP Channel 5.		
		010110	SigmaDSP Channel 6.		
		010111	SigmaDSP Channel 7.		
		011000	SigmaDSP Channel 8.		
		011001	SigmaDSP Channel 9.		
		011010	SigmaDSP Channel 10.		
		011011	SigmaDSP Channel 11.		
		011100	SigmaDSP Channel 12.		
		011101	SigmaDSP Channel 13.		
		011110	SigmaDSP Channel 14.		
		011111	SigmaDSP Channel 15.		
		100000	Output ASRC Channel 0.		
		100001	Output ASRC Channel 1.		
		100010	Output ASRC Channel 2.		
		100011	Output ASRC Channel 3.		
		100100	ADC Channel 0.		
		100101	ADC Channel 1.		
		101000	Digital Microphone Channel 0.		
		101001	Digital Microphone Channel 1.		
		101010	Digital Microphone Channel 2.		
		101011	Digital Microphone Channel 3.		
		110000	Fast to Slow Decimator Channel 0.		
		110001	Fast to Slow Decimator Channel 1.		
		110010	Fast to Slow Decimator Channel 2.		
		110011	Fast to Slow Decimator Channel 3.		
		110100	Fast to Slow Decimator Channel 4.		
		110101	Fast to Slow Decimator Channel 5.		
		110110	Fast to Slow Decimator Channel 6.		
		110111	Fast to Slow Decimator Channel 7.		
		111111	No output. Slot not used.		



**SERIAL PORT 0 OUTPUT ROUTING SLOT 4 REGISTER**

Address: 0xC0BB, Reset: 0x3F, Name: SPT0\_ROUTE4

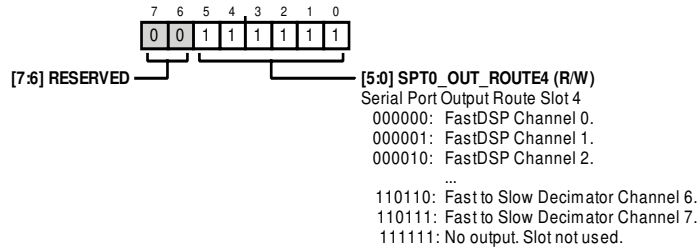

**Table 211. Bit Descriptions for SPT0\_ROUTE4**

Bits	Bit Name	Settings	Description	Reset	Access
[7:6]	RESERVED		Reserved.	0x0	R
[5:0]	SPT0_OUT_ROUTE4		Serial Port Output Route Slot 4.	0x3F	R/W
		000000	FastDSP Channel 0.		
		000001	FastDSP Channel 1.		
		000010	FastDSP Channel 2.		
		000011	FastDSP Channel 3.		
		000100	FastDSP Channel 4.		
		000101	FastDSP Channel 5.		
		000110	FastDSP Channel 6.		
		000111	FastDSP Channel 7.		
		001000	FastDSP Channel 8.		
		001001	FastDSP Channel 9.		
		001010	FastDSP Channel 10.		
		001011	FastDSP Channel 11.		
		001100	FastDSP Channel 12.		
		001101	FastDSP Channel 13.		
		001110	FastDSP Channel 14.		
		001111	FastDSP Channel 15.		
		010000	SigmaDSP Channel 0.		
		010001	SigmaDSP Channel 1.		
		010010	SigmaDSP Channel 2.		
		010011	SigmaDSP Channel 3.		
		010100	SigmaDSP Channel 4.		
		010101	SigmaDSP Channel 5.		
		010110	SigmaDSP Channel 6.		
		010111	SigmaDSP Channel 7.		
		011000	SigmaDSP Channel 8.		
		011001	SigmaDSP Channel 9.		
		011010	SigmaDSP Channel 10.		
		011011	SigmaDSP Channel 11.		
		011100	SigmaDSP Channel 12.		
		011101	SigmaDSP Channel 13.		
		011110	SigmaDSP Channel 14.		
		011111	SigmaDSP Channel 15.		
		100000	Output ASRC Channel 0.		
		100001	Output ASRC Channel 1.		
		100010	Output ASRC Channel 2.		
		100011	Output ASRC Channel 3.		

Bits	Bit Name	Settings	Description	Reset	Access
		100100	ADC Channel 0.		
		100101	ADC Channel 1.		
		101000	Digital Microphone Channel 0.		
		101001	Digital Microphone Channel 1.		
		101010	Digital Microphone Channel 2.		
		101011	Digital Microphone Channel 3.		
		110000	Fast to Slow Decimator Channel 0.		
		110001	Fast to Slow Decimator Channel 1.		
		110010	Fast to Slow Decimator Channel 2.		
		110011	Fast to Slow Decimator Channel 3.		
		110100	Fast to Slow Decimator Channel 4.		
		110101	Fast to Slow Decimator Channel 5.		
		110110	Fast to Slow Decimator Channel 6.		
		110111	Fast to Slow Decimator Channel 7.		
		111111	No output. Slot not used.		

**SERIAL PORT 0 OUTPUT ROUTING SLOT 5 REGISTER**

Address: 0xC0BC, Reset: 0x3F, Name: SPT0\_ROUTE5

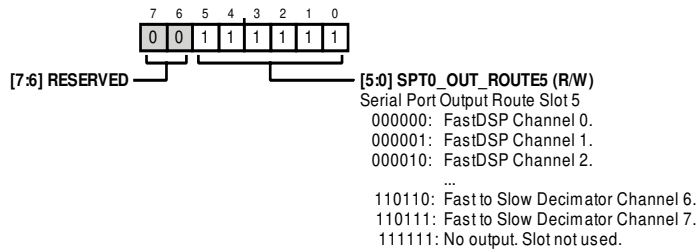

Table 212. Bit Descriptions for SPT0\_ROUTE5

Bits	Bit Name	Settings	Description	Reset	Access
[7:6]	RESERVED		Reserved.	0x0	R
[5:0]	SPT0_OUT_ROUTE5	000000 000001 000010 000011 000100 000101 000110 000111 001000 001001 001010 001011 001100 001101 001110 001111	Serial Port Output Route Slot 5. FastDSP Channel 0. FastDSP Channel 1. FastDSP Channel 2. FastDSP Channel 3. FastDSP Channel 4. FastDSP Channel 5. FastDSP Channel 6. FastDSP Channel 7. FastDSP Channel 8. FastDSP Channel 9. FastDSP Channel 10. FastDSP Channel 11. FastDSP Channel 12. FastDSP Channel 13. FastDSP Channel 14. FastDSP Channel 15.	0x3F	R/W

Bits	Bit Name	Settings	Description	Reset	Access
		010000	SigmaDSP Channel 0.		
		010001	SigmaDSP Channel 1.		
		010010	SigmaDSP Channel 2.		
		010011	SigmaDSP Channel 3.		
		010100	SigmaDSP Channel 4.		
		010101	SigmaDSP Channel 5.		
		010110	SigmaDSP Channel 6.		
		010111	SigmaDSP Channel 7.		
		011000	SigmaDSP Channel 8.		
		011001	SigmaDSP Channel 9.		
		011010	SigmaDSP Channel 10.		
		011011	SigmaDSP Channel 11.		
		011100	SigmaDSP Channel 12.		
		011101	SigmaDSP Channel 13.		
		011110	SigmaDSP Channel 14.		
		011111	SigmaDSP Channel 15.		
		100000	Output ASRC Channel 0.		
		100001	Output ASRC Channel 1.		
		100010	Output ASRC Channel 2.		
		100011	Output ASRC Channel 3.		
		100100	ADC Channel 0.		
		100101	ADC Channel 1.		
		101000	Digital Microphone Channel 0.		
		101001	Digital Microphone Channel 1.		
		101010	Digital Microphone Channel 2.		
		101011	Digital Microphone Channel 3.		
		110000	Fast to Slow Decimator Channel 0.		
		110001	Fast to Slow Decimator Channel 1.		
		110010	Fast to Slow Decimator Channel 2.		
		110011	Fast to Slow Decimator Channel 3.		
		110100	Fast to Slow Decimator Channel 4.		
		110101	Fast to Slow Decimator Channel 5.		
		110110	Fast to Slow Decimator Channel 6.		
		110111	Fast to Slow Decimator Channel 7.		
		111111	No output. Slot not used.		

**SERIAL PORT 0 OUTPUT ROUTING SLOT 6 REGISTER**

Address: 0xC0BD, Reset: 0x3F, Name: SPT0\_ROUTE6

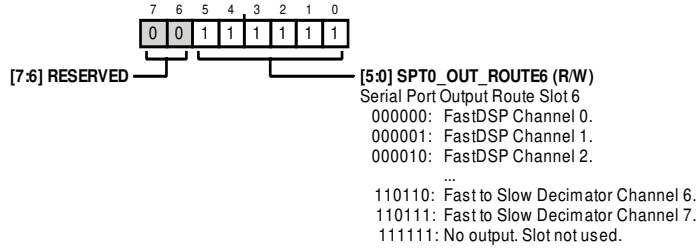

**Table 213. Bit Descriptions for SPT0\_ROUTE6**

Bits	Bit Name	Settings	Description	Reset	Access
[7:6]	RESERVED		Reserved.	0x0	R
[5:0]	SPT0_OUT_ROUTE6		Serial Port Output Route Slot 6.	0x3F	R/W
		000000	FastDSP Channel 0.		
		000001	FastDSP Channel 1.		
		000010	FastDSP Channel 2.		
		000011	FastDSP Channel 3.		
		000100	FastDSP Channel 4.		
		000101	FastDSP Channel 5.		
		000110	FastDSP Channel 6.		
		000111	FastDSP Channel 7.		
		001000	FastDSP Channel 8.		
		001001	FastDSP Channel 9.		
		001010	FastDSP Channel 10.		
		001011	FastDSP Channel 11.		
		001100	FastDSP Channel 12.		
		001101	FastDSP Channel 13.		
		001110	FastDSP Channel 14.		
		001111	FastDSP Channel 15.		
		010000	SigmaDSP Channel 0.		
		010001	SigmaDSP Channel 1.		
		010010	SigmaDSP Channel 2.		
		010011	SigmaDSP Channel 3.		
		010100	SigmaDSP Channel 4.		
		010101	SigmaDSP Channel 5.		
		010110	SigmaDSP Channel 6.		
		010111	SigmaDSP Channel 7.		
		011000	SigmaDSP Channel 8.		
		011001	SigmaDSP Channel 9.		
		011010	SigmaDSP Channel 10.		
		011011	SigmaDSP Channel 11.		
		011100	SigmaDSP Channel 12.		
		011101	SigmaDSP Channel 13.		
		011110	SigmaDSP Channel 14.		
		011111	SigmaDSP Channel 15.		
		100000	Output ASRC Channel 0.		
		100001	Output ASRC Channel 1.		
		100010	Output ASRC Channel 2.		
		100011	Output ASRC Channel 3.		

Bits	Bit Name	Settings	Description	Reset	Access
		100100	ADC Channel 0.		
		100101	ADC Channel 1.		
		101000	Digital Microphone Channel 0.		
		101001	Digital Microphone Channel 1.		
		101010	Digital Microphone Channel 2.		
		101011	Digital Microphone Channel 3.		
		110000	Fast to Slow Decimator Channel 0.		
		110001	Fast to Slow Decimator Channel 1.		
		110010	Fast to Slow Decimator Channel 2.		
		110011	Fast to Slow Decimator Channel 3.		
		110100	Fast to Slow Decimator Channel 4.		
		110101	Fast to Slow Decimator Channel 5.		
		110110	Fast to Slow Decimator Channel 6.		
		110111	Fast to Slow Decimator Channel 7.		
		111111	No output. Slot not used.		

**SERIAL PORT 0 OUTPUT ROUTING SLOT 7 REGISTER**

Address: 0xC0BE, Reset: 0x3F, Name: SPT0\_ROUTE7

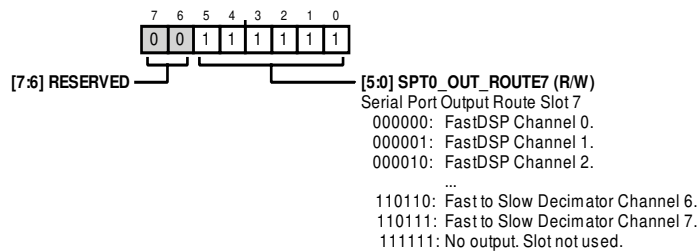

Table 214. Bit Descriptions for SPT0\_ROUTE7

Bits	Bit Name	Settings	Description	Reset	Access
[7:6]	RESERVED		Reserved.	0x0	R
[5:0]	SPT0_OUT_ROUTE7	000000	FastDSP Channel 0.	0x3F	R/W
		000001	FastDSP Channel 1.		
		000010	FastDSP Channel 2.		
		000011	FastDSP Channel 3.		
		000100	FastDSP Channel 4.		
		000101	FastDSP Channel 5.		
		000110	FastDSP Channel 6.		
		000111	FastDSP Channel 7.		
		001000	FastDSP Channel 8.		
		001001	FastDSP Channel 9.		
		001010	FastDSP Channel 10.		
		001011	FastDSP Channel 11.		
		001100	FastDSP Channel 12.		
		001101	FastDSP Channel 13.		
		001110	FastDSP Channel 14.		
		001111	FastDSP Channel 15.		

Bits	Bit Name	Settings	Description	Reset	Access
		010000	SigmaDSP Channel 0.		
		010001	SigmaDSP Channel 1.		
		010010	SigmaDSP Channel 2.		
		010011	SigmaDSP Channel 3.		
		010100	SigmaDSP Channel 4.		
		010101	SigmaDSP Channel 5.		
		010110	SigmaDSP Channel 6.		
		010111	SigmaDSP Channel 7.		
		011000	SigmaDSP Channel 8.		
		011001	SigmaDSP Channel 9.		
		011010	SigmaDSP Channel 10.		
		011011	SigmaDSP Channel 11.		
		011100	SigmaDSP Channel 12.		
		011101	SigmaDSP Channel 13.		
		011110	SigmaDSP Channel 14.		
		011111	SigmaDSP Channel 15.		
		100000	Output ASRC Channel 0.		
		100001	Output ASRC Channel 1.		
		100010	Output ASRC Channel 2.		
		100011	Output ASRC Channel 3.		
		100100	ADC Channel 0.		
		100101	ADC Channel 1.		
		101000	Digital Microphone Channel 0.		
		101001	Digital Microphone Channel 1.		
		101010	Digital Microphone Channel 2.		
		101011	Digital Microphone Channel 3.		
		110000	Fast to Slow Decimator Channel 0.		
		110001	Fast to Slow Decimator Channel 1.		
		110010	Fast to Slow Decimator Channel 2.		
		110011	Fast to Slow Decimator Channel 3.		
		110100	Fast to Slow Decimator Channel 4.		
		110101	Fast to Slow Decimator Channel 5.		
		110110	Fast to Slow Decimator Channel 6.		
		110111	Fast to Slow Decimator Channel 7.		
		111111	No output. Slot not used.		

**SERIAL PORT 0 OUTPUT ROUTING SLOT 8 REGISTER**

Address: 0xC0BF, Reset: 0x3F, Name: SPT0\_ROUTE8

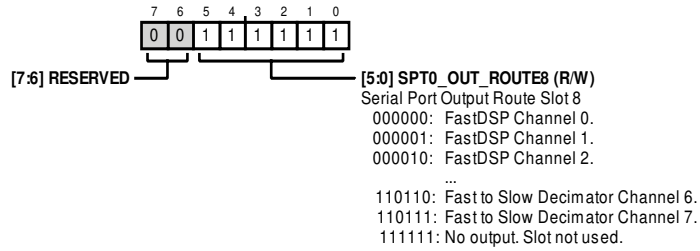

Table 215. Bit Descriptions for SPT0\_ROUTE8

Bits	Bit Name	Settings	Description	Reset	Access
[7:6]	RESERVED		Reserved.	0x0	R
[5:0]	SPT0_OUT_ROUTE8		Serial Port Output Route Slot 8.	0x3F	R/W
		000000	FastDSP Channel 0.		
		000001	FastDSP Channel 1.		
		000010	FastDSP Channel 2.		
		000011	FastDSP Channel 3.		
		000100	FastDSP Channel 4.		
		000101	FastDSP Channel 5.		
		000110	FastDSP Channel 6.		
		000111	FastDSP Channel 7.		
		001000	FastDSP Channel 8.		
		001001	FastDSP Channel 9.		
		001010	FastDSP Channel 10.		
		001011	FastDSP Channel 11.		
		001100	FastDSP Channel 12.		
		001101	FastDSP Channel 13.		
		001110	FastDSP Channel 14.		
		001111	FastDSP Channel 15.		
		010000	SigmaDSP Channel 0.		
		010001	SigmaDSP Channel 1.		
		010010	SigmaDSP Channel 2.		
		010011	SigmaDSP Channel 3.		
		010100	SigmaDSP Channel 4.		
		010101	SigmaDSP Channel 5.		
		010110	SigmaDSP Channel 6.		
		010111	SigmaDSP Channel 7.		
		011000	SigmaDSP Channel 8.		
		011001	SigmaDSP Channel 9.		
		011010	SigmaDSP Channel 10.		
		011011	SigmaDSP Channel 11.		
		011100	SigmaDSP Channel 12.		
		011101	SigmaDSP Channel 13.		
		011110	SigmaDSP Channel 14.		
		011111	SigmaDSP Channel 15.		
		100000	Output ASRC Channel 0.		
		100001	Output ASRC Channel 1.		
		100010	Output ASRC Channel 2.		
		100011	Output ASRC Channel 3.		

Bits	Bit Name	Settings	Description	Reset	Access
		100100	ADC Channel 0.		
		100101	ADC Channel 1.		
		101000	Digital Microphone Channel 0.		
		101001	Digital Microphone Channel 1.		
		101010	Digital Microphone Channel 2.		
		101011	Digital Microphone Channel 3.		
		110000	Fast to Slow Decimator Channel 0.		
		110001	Fast to Slow Decimator Channel 1.		
		110010	Fast to Slow Decimator Channel 2.		
		110011	Fast to Slow Decimator Channel 3.		
		110100	Fast to Slow Decimator Channel 4.		
		110101	Fast to Slow Decimator Channel 5.		
		110110	Fast to Slow Decimator Channel 6.		
		110111	Fast to Slow Decimator Channel 7.		
		111111	No output. Slot not used.		

**SERIAL PORT 0 OUTPUT ROUTING SLOT 9 REGISTER**

Address: 0xC0C0, Reset: 0x3F, Name: SPT0\_ROUTE9

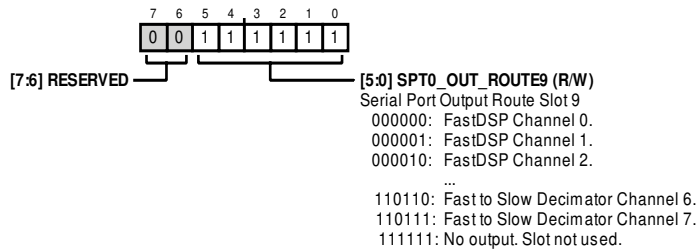

Table 216. Bit Descriptions for SPT0\_ROUTE9

Bits	Bit Name	Settings	Description	Reset	Access
[7:6]	RESERVED		Reserved.	0x0	R
[5:0]	SPT0_OUT_ROUTE9	000000 000001 000010 000011 000100 000101 000110 000111 001000 001001 001010 001011 001100 001101 001110 001111	Serial Port Output Route Slot 9. FastDSP Channel 0. FastDSP Channel 1. FastDSP Channel 2. FastDSP Channel 3. FastDSP Channel 4. FastDSP Channel 5. FastDSP Channel 6. FastDSP Channel 7. FastDSP Channel 8. FastDSP Channel 9. FastDSP Channel 10. FastDSP Channel 11. FastDSP Channel 12. FastDSP Channel 13. FastDSP Channel 14. FastDSP Channel 15.	0x3F	R/W



Bits	Bit Name	Settings	Description	Reset	Access
		010000	SigmaDSP Channel 0.		
		010001	SigmaDSP Channel 1.		
		010010	SigmaDSP Channel 2.		
		010011	SigmaDSP Channel 3.		
		010100	SigmaDSP Channel 4.		
		010101	SigmaDSP Channel 5.		
		010110	SigmaDSP Channel 6.		
		010111	SigmaDSP Channel 7.		
		011000	SigmaDSP Channel 8.		
		011001	SigmaDSP Channel 9.		
		011010	SigmaDSP Channel 10.		
		011011	SigmaDSP Channel 11.		
		011100	SigmaDSP Channel 12.		
		011101	SigmaDSP Channel 13.		
		011110	SigmaDSP Channel 14.		
		011111	SigmaDSP Channel 15.		
		100000	Output ASRC Channel 0.		
		100001	Output ASRC Channel 1.		
		100010	Output ASRC Channel 2.		
		100011	Output ASRC Channel 3.		
		100100	ADC Channel 0.		
		100101	ADC Channel 1.		
		101000	Digital Microphone Channel 0.		
		101001	Digital Microphone Channel 1.		
		101010	Digital Microphone Channel 2.		
		101011	Digital Microphone Channel 3.		
		110000	Fast to Slow Decimator Channel 0.		
		110001	Fast to Slow Decimator Channel 1.		
		110010	Fast to Slow Decimator Channel 2.		
		110011	Fast to Slow Decimator Channel 3.		
		110100	Fast to Slow Decimator Channel 4.		
		110101	Fast to Slow Decimator Channel 5.		
		110110	Fast to Slow Decimator Channel 6.		
		110111	Fast to Slow Decimator Channel 7.		
		111111	No output. Slot not used.		

**SERIAL PORT 0 OUTPUT ROUTING SLOT 10 REGISTER**

Address: 0xC0C1, Reset: 0x3F, Name: SPT0\_ROUTE10

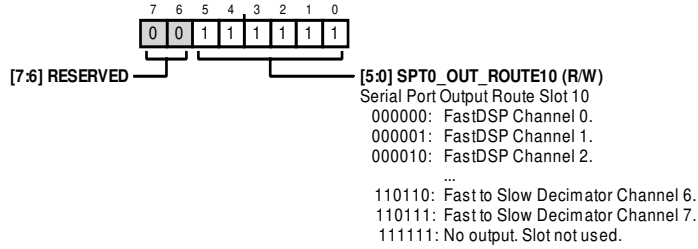

**Table 217. Bit Descriptions for SPT0\_ROUTE10**

Bits	Bit Name	Settings	Description	Reset	Access
[7:6]	RESERVED		Reserved.	0x0	R
[5:0]	SPT0_OUT_ROUTE10		Serial Port Output Route Slot 10.	0x3F	R/W
		000000	FastDSP Channel 0.		
		000001	FastDSP Channel 1.		
		000010	FastDSP Channel 2.		
		000011	FastDSP Channel 3.		
		000100	FastDSP Channel 4.		
		000101	FastDSP Channel 5.		
		000110	FastDSP Channel 6.		
		000111	FastDSP Channel 7.		
		001000	FastDSP Channel 8.		
		001001	FastDSP Channel 9.		
		001010	FastDSP Channel 10.		
		001011	FastDSP Channel 11.		
		001100	FastDSP Channel 12.		
		001101	FastDSP Channel 13.		
		001110	FastDSP Channel 14.		
		001111	FastDSP Channel 15.		
		010000	SigmaDSP Channel 0.		
		010001	SigmaDSP Channel 1.		
		010010	SigmaDSP Channel 2.		
		010011	SigmaDSP Channel 3.		
		010100	SigmaDSP Channel 4.		
		010101	SigmaDSP Channel 5.		
		010110	SigmaDSP Channel 6.		
		010111	SigmaDSP Channel 7.		
		011000	SigmaDSP Channel 8.		
		011001	SigmaDSP Channel 9.		
		011010	SigmaDSP Channel 10.		
		011011	SigmaDSP Channel 11.		
		011100	SigmaDSP Channel 12.		
		011101	SigmaDSP Channel 13.		
		011110	SigmaDSP Channel 14.		
		011111	SigmaDSP Channel 15.		
		100000	Output ASRC Channel 0.		
		100001	Output ASRC Channel 1.		
		100010	Output ASRC Channel 2.		
		100011	Output ASRC Channel 3.		

Bits	Bit Name	Settings	Description	Reset	Access
		100100	ADC Channel 0.		
		100101	ADC Channel 1.		
		101000	Digital Microphone Channel 0.		
		101001	Digital Microphone Channel 1.		
		101010	Digital Microphone Channel 2.		
		101011	Digital Microphone Channel 3.		
		110000	Fast to Slow Decimator Channel 0.		
		110001	Fast to Slow Decimator Channel 1.		
		110010	Fast to Slow Decimator Channel 2.		
		110011	Fast to Slow Decimator Channel 3.		
		110100	Fast to Slow Decimator Channel 4.		
		110101	Fast to Slow Decimator Channel 5.		
		110110	Fast to Slow Decimator Channel 6.		
		110111	Fast to Slow Decimator Channel 7.		
		111111	No output. Slot not used.		

**SERIAL PORT 0 OUTPUT ROUTING SLOT 11 REGISTER**

Address: 0xC0C2, Reset: 0x3F, Name: SPT0\_ROUTE11

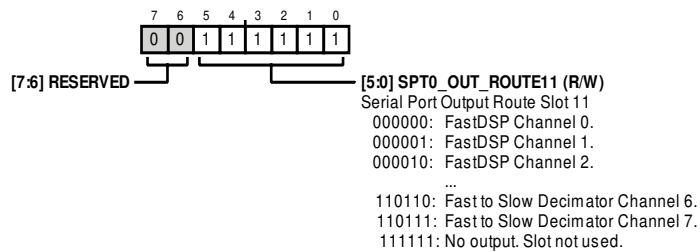

Table 218. Bit Descriptions for SPT0\_ROUTE11

Bits	Bit Name	Settings	Description	Reset	Access
[7:6]	RESERVED		Reserved.	0x0	R
[5:0]	SPT0_OUT_ROUTE11	000000	FastDSP Channel 0.	0x3F	R/W
		000001	FastDSP Channel 1.		
		000010	FastDSP Channel 2.		
		000011	FastDSP Channel 3.		
		000100	FastDSP Channel 4.		
		000101	FastDSP Channel 5.		
		000110	FastDSP Channel 6.		
		000111	FastDSP Channel 7.		
		001000	FastDSP Channel 8.		
		001001	FastDSP Channel 9.		
		001010	FastDSP Channel 10.		
		001011	FastDSP Channel 11.		
		001100	FastDSP Channel 12.		
		001101	FastDSP Channel 13.		
		001110	FastDSP Channel 14.		
		001111	FastDSP Channel 15.		

Bits	Bit Name	Settings	Description	Reset	Access
		010000	SigmaDSP Channel 0.		
		010001	SigmaDSP Channel 1.		
		010010	SigmaDSP Channel 2.		
		010011	SigmaDSP Channel 3.		
		010100	SigmaDSP Channel 4.		
		010101	SigmaDSP Channel 5.		
		010110	SigmaDSP Channel 6.		
		010111	SigmaDSP Channel 7.		
		011000	SigmaDSP Channel 8.		
		011001	SigmaDSP Channel 9.		
		011010	SigmaDSP Channel 10.		
		011011	SigmaDSP Channel 11.		
		011100	SigmaDSP Channel 12.		
		011101	SigmaDSP Channel 13.		
		011110	SigmaDSP Channel 14.		
		011111	SigmaDSP Channel 15.		
		100000	Output ASRC Channel 0.		
		100001	Output ASRC Channel 1.		
		100010	Output ASRC Channel 2.		
		100011	Output ASRC Channel 3.		
		100100	ADC Channel 0.		
		100101	ADC Channel 1.		
		101000	Digital Microphone Channel 0.		
		101001	Digital Microphone Channel 1.		
		101010	Digital Microphone Channel 2.		
		101011	Digital Microphone Channel 3.		
		110000	Fast to Slow Decimator Channel 0.		
		110001	Fast to Slow Decimator Channel 1.		
		110010	Fast to Slow Decimator Channel 2.		
		110011	Fast to Slow Decimator Channel 3.		
		110100	Fast to Slow Decimator Channel 4.		
		110101	Fast to Slow Decimator Channel 5.		
		110110	Fast to Slow Decimator Channel 6.		
		110111	Fast to Slow Decimator Channel 7.		
		111111	No output. Slot not used.		

**SERIAL PORT 0 OUTPUT ROUTING SLOT 12 REGISTER**

Address: 0xC0C3, Reset: 0x3F, Name: SPT0\_ROUTE12

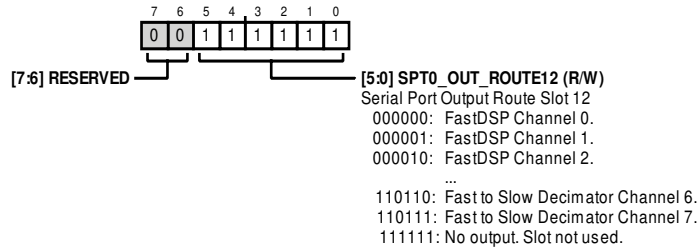

**Table 219. Bit Descriptions for SPT0\_ROUTE12**

Bits	Bit Name	Settings	Description	Reset	Access
[7:6]	RESERVED		Reserved.	0x0	R
[5:0]	SPT0_OUT_ROUTE12		Serial Port Output Route Slot 12.	0x3F	R/W
		000000	FastDSP Channel 0.		
		000001	FastDSP Channel 1.		
		000010	FastDSP Channel 2.		
		000011	FastDSP Channel 3.		
		000100	FastDSP Channel 4.		
		000101	FastDSP Channel 5.		
		000110	FastDSP Channel 6.		
		000111	FastDSP Channel 7.		
		001000	FastDSP Channel 8.		
		001001	FastDSP Channel 9.		
		001010	FastDSP Channel 10.		
		001011	FastDSP Channel 11.		
		001100	FastDSP Channel 12.		
		001101	FastDSP Channel 13.		
		001110	FastDSP Channel 14.		
		001111	FastDSP Channel 15.		
		010000	SigmaDSP Channel 0.		
		010001	SigmaDSP Channel 1.		
		010010	SigmaDSP Channel 2.		
		010011	SigmaDSP Channel 3.		
		010100	SigmaDSP Channel 4.		
		010101	SigmaDSP Channel 5.		
		010110	SigmaDSP Channel 6.		
		010111	SigmaDSP Channel 7.		
		011000	SigmaDSP Channel 8.		
		011001	SigmaDSP Channel 9.		
		011010	SigmaDSP Channel 10.		
		011011	SigmaDSP Channel 11.		
		011100	SigmaDSP Channel 12.		
		011101	SigmaDSP Channel 13.		
		011110	SigmaDSP Channel 14.		
		011111	SigmaDSP Channel 15.		
		100000	Output ASRC Channel 0.		
		100001	Output ASRC Channel 1.		
		100010	Output ASRC Channel 2.		
		100011	Output ASRC Channel 3.		

Bits	Bit Name	Settings	Description	Reset	Access
		100100	ADC Channel 0.		
		100101	ADC Channel 1.		
		101000	Digital Microphone Channel 0.		
		101001	Digital Microphone Channel 1.		
		101010	Digital Microphone Channel 2.		
		101011	Digital Microphone Channel 3.		
		110000	Fast to Slow Decimator Channel 0.		
		110001	Fast to Slow Decimator Channel 1.		
		110010	Fast to Slow Decimator Channel 2.		
		110011	Fast to Slow Decimator Channel 3.		
		110100	Fast to Slow Decimator Channel 4.		
		110101	Fast to Slow Decimator Channel 5.		
		110110	Fast to Slow Decimator Channel 6.		
		110111	Fast to Slow Decimator Channel 7.		
		111111	No output. Slot not used.		

**SERIAL PORT 0 OUTPUT ROUTING SLOT 13 REGISTER**

Address: 0xC0C4, Reset: 0x3F, Name: SPT0\_ROUTE13

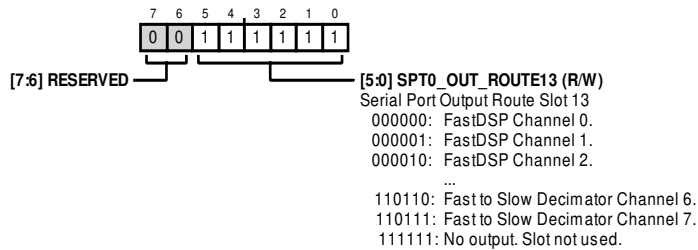

Table 220. Bit Descriptions for SPT0\_ROUTE13

Bits	Bit Name	Settings	Description	Reset	Access
[7:6]	RESERVED		Reserved.	0x0	R
[5:0]	SPT0_OUT_ROUTE13		Serial Port Output Route Slot 13.	0x3F	R/W
		000000	FastDSP Channel 0.		
		000001	FastDSP Channel 1.		
		000010	FastDSP Channel 2.		
		000011	FastDSP Channel 3.		
		000100	FastDSP Channel 4.		
		000101	FastDSP Channel 5.		
		000110	FastDSP Channel 6.		
		000111	FastDSP Channel 7.		
		001000	FastDSP Channel 8.		
		001001	FastDSP Channel 9.		
		001010	FastDSP Channel 10.		
		001011	FastDSP Channel 11.		
		001100	FastDSP Channel 12.		
		001101	FastDSP Channel 13.		
		001110	FastDSP Channel 14.		
		001111	FastDSP Channel 15.		

Bits	Bit Name	Settings	Description	Reset	Access
		010000	SigmaDSP Channel 0.		
		010001	SigmaDSP Channel 1.		
		010010	SigmaDSP Channel 2.		
		010011	SigmaDSP Channel 3.		
		010100	SigmaDSP Channel 4.		
		010101	SigmaDSP Channel 5.		
		010110	SigmaDSP Channel 6.		
		010111	SigmaDSP Channel 7.		
		011000	SigmaDSP Channel 8.		
		011001	SigmaDSP Channel 9.		
		011010	SigmaDSP Channel 10.		
		011011	SigmaDSP Channel 11.		
		011100	SigmaDSP Channel 12.		
		011101	SigmaDSP Channel 13.		
		011110	SigmaDSP Channel 14.		
		011111	SigmaDSP Channel 15.		
		100000	Output ASRC Channel 0.		
		100001	Output ASRC Channel 1.		
		100010	Output ASRC Channel 2.		
		100011	Output ASRC Channel 3.		
		100100	ADC Channel 0.		
		100101	ADC Channel 1.		
		101000	Digital Microphone Channel 0.		
		101001	Digital Microphone Channel 1.		
		101010	Digital Microphone Channel 2.		
		101011	Digital Microphone Channel 3.		
		110000	Fast to Slow Decimator Channel 0.		
		110001	Fast to Slow Decimator Channel 1.		
		110010	Fast to Slow Decimator Channel 2.		
		110011	Fast to Slow Decimator Channel 3.		
		110100	Fast to Slow Decimator Channel 4.		
		110101	Fast to Slow Decimator Channel 5.		
		110110	Fast to Slow Decimator Channel 6.		
		110111	Fast to Slow Decimator Channel 7.		
		111111	No output. Slot not used.		

**SERIAL PORT 0 OUTPUT ROUTING SLOT 14 REGISTER**

Address: 0xC0C5, Reset: 0x3F, Name: SPT0\_ROUTE14

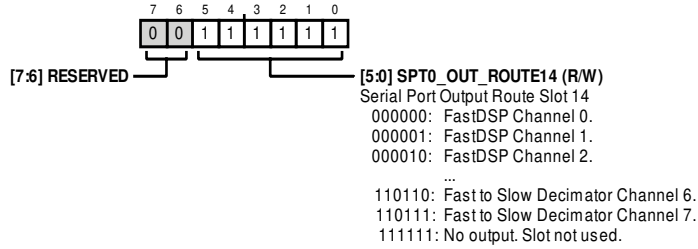

**Table 221. Bit Descriptions for SPT0\_ROUTE14**

Bits	Bit Name	Settings	Description	Reset	Access
[7:6]	RESERVED		Reserved.	0x0	R
[5:0]	SPT0_OUT_ROUTE14		Serial Port Output Route Slot 14.	0x3F	R/W
		000000	FastDSP Channel 0.		
		000001	FastDSP Channel 1.		
		000010	FastDSP Channel 2.		
		000011	FastDSP Channel 3.		
		000100	FastDSP Channel 4.		
		000101	FastDSP Channel 5.		
		000110	FastDSP Channel 6.		
		000111	FastDSP Channel 7.		
		001000	FastDSP Channel 8.		
		001001	FastDSP Channel 9.		
		001010	FastDSP Channel 10.		
		001011	FastDSP Channel 11.		
		001100	FastDSP Channel 12.		
		001101	FastDSP Channel 13.		
		001110	FastDSP Channel 14.		
		001111	FastDSP Channel 15.		
		010000	SigmaDSP Channel 0.		
		010001	SigmaDSP Channel 1.		
		010010	SigmaDSP Channel 2.		
		010011	SigmaDSP Channel 3.		
		010100	SigmaDSP Channel 4.		
		010101	SigmaDSP Channel 5.		
		010110	SigmaDSP Channel 6.		
		010111	SigmaDSP Channel 7.		
		011000	SigmaDSP Channel 8.		
		011001	SigmaDSP Channel 9.		
		011010	SigmaDSP Channel 10.		
		011011	SigmaDSP Channel 11.		
		011100	SigmaDSP Channel 12.		
		011101	SigmaDSP Channel 13.		
		011110	SigmaDSP Channel 14.		
		011111	SigmaDSP Channel 15.		
		100000	Output ASRC Channel 0.		
		100001	Output ASRC Channel 1.		
		100010	Output ASRC Channel 2.		
		100011	Output ASRC Channel 3.		



Bits	Bit Name	Settings	Description	Reset	Access
		100100	ADC Channel 0.		
		100101	ADC Channel 1.		
		101000	Digital Microphone Channel 0.		
		101001	Digital Microphone Channel 1.		
		101010	Digital Microphone Channel 2.		
		101011	Digital Microphone Channel 3.		
		110000	Fast to Slow Decimator Channel 0.		
		110001	Fast to Slow Decimator Channel 1.		
		110010	Fast to Slow Decimator Channel 2.		
		110011	Fast to Slow Decimator Channel 3.		
		110100	Fast to Slow Decimator Channel 4.		
		110101	Fast to Slow Decimator Channel 5.		
		110110	Fast to Slow Decimator Channel 6.		
		110111	Fast to Slow Decimator Channel 7.		
		111111	No output. Slot not used.		

**SERIAL PORT 0 OUTPUT ROUTING SLOT 15 REGISTER**

Address: 0xC0C6, Reset: 0x3F, Name: SPT0\_ROUTE15

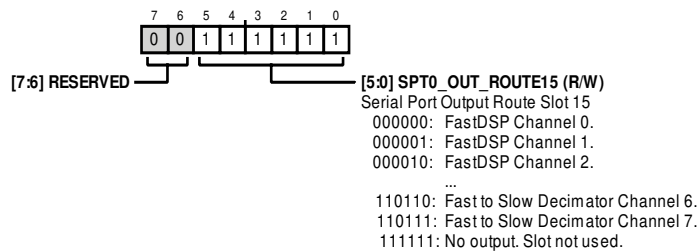

Table 222. Bit Descriptions for SPT0\_ROUTE15

Bits	Bit Name	Settings	Description	Reset	Access
[7:6]	RESERVED		Reserved.	0x0	R
[5:0]	SPT0_OUT_ROUTE15	000000	FastDSP Channel 0.	0x3F	R/W
		000001	FastDSP Channel 1.		
		000010	FastDSP Channel 2.		
		000011	FastDSP Channel 3.		
		000100	FastDSP Channel 4.		
		000101	FastDSP Channel 5.		
		000110	FastDSP Channel 6.		
		000111	FastDSP Channel 7.		
		001000	FastDSP Channel 8.		
		001001	FastDSP Channel 9.		
		001010	FastDSP Channel 10.		
		001011	FastDSP Channel 11.		
		001100	FastDSP Channel 12.		
		001101	FastDSP Channel 13.		
		001110	FastDSP Channel 14.		
		001111	FastDSP Channel 15.		

Bits	Bit Name	Settings	Description	Reset	Access
		010000	SigmaDSP Channel 0.		
		010001	SigmaDSP Channel 1.		
		010010	SigmaDSP Channel 2.		
		010011	SigmaDSP Channel 3.		
		010100	SigmaDSP Channel 4.		
		010101	SigmaDSP Channel 5.		
		010110	SigmaDSP Channel 6.		
		010111	SigmaDSP Channel 7.		
		011000	SigmaDSP Channel 8.		
		011001	SigmaDSP Channel 9.		
		011010	SigmaDSP Channel 10.		
		011011	SigmaDSP Channel 11.		
		011100	SigmaDSP Channel 12.		
		011101	SigmaDSP Channel 13.		
		011110	SigmaDSP Channel 14.		
		011111	SigmaDSP Channel 15.		
		100000	Output ASRC Channel 0.		
		100001	Output ASRC Channel 1.		
		100010	Output ASRC Channel 2.		
		100011	Output ASRC Channel 3.		
		100100	ADC Channel 0.		
		100101	ADC Channel 1.		
		101000	Digital Microphone Channel 0.		
		101001	Digital Microphone Channel 1.		
		101010	Digital Microphone Channel 2.		
		101011	Digital Microphone Channel 3.		
		110000	Fast to Slow Decimator Channel 0.		
		110001	Fast to Slow Decimator Channel 1.		
		110010	Fast to Slow Decimator Channel 2.		
		110011	Fast to Slow Decimator Channel 3.		
		110100	Fast to Slow Decimator Channel 4.		
		110101	Fast to Slow Decimator Channel 5.		
		110110	Fast to Slow Decimator Channel 6.		
		110111	Fast to Slow Decimator Channel 7.		
		111111	No output. Slot not used.		

**PDM SAMPLE RATE AND FILTERING CONTROL REGISTER**

Address: 0xC0DC, Reset: 0x02, Name: PDM\_CTRL1

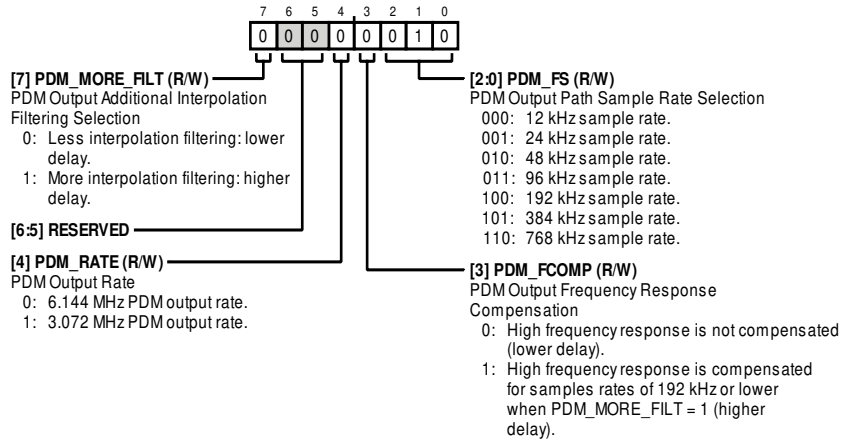

**Table 223. Bit Descriptions for PDM\_CTRL1**

Bits	Bit Name	Settings	Description	Reset	Access
7	PDM_MORE_FILT	0 1	PDM Output Additional Interpolation Filtering Selection. Less interpolation filtering: lower delay. More interpolation filtering: higher delay.	0x0	R/W
[6:5]	RESERVED		Reserved.	0x0	R
4	PDM_RATE	0 1	PDM Output Rate. 6.144 MHz PDM output rate. 3.072 MHz PDM output rate.	0x0	R/W
3	PDM_FCOMP	0 1	PDM Output Frequency Response Compensation. High frequency response is not compensated (lower delay). High frequency response is compensated for samples rates of 192 kHz or lower when PDM_MORE_FILT = 1 (higher delay).	0x0	R/W
[2:0]	PDM_FS	000 001 010 011 100 101 110	PDM Output Path Sample Rate Selection. 12 kHz sample rate. 24 kHz sample rate. 48 kHz sample rate. 96 kHz sample rate. 192 kHz sample rate. 384 kHz sample rate. 768 kHz sample rate.	0x2	R/W

**PDM MUTING, HIGH-PASS, AND VOLUME OPTIONS REGISTER**

Address: 0xC0DD, Reset: 0xC4, Name: PDM\_CTRL2

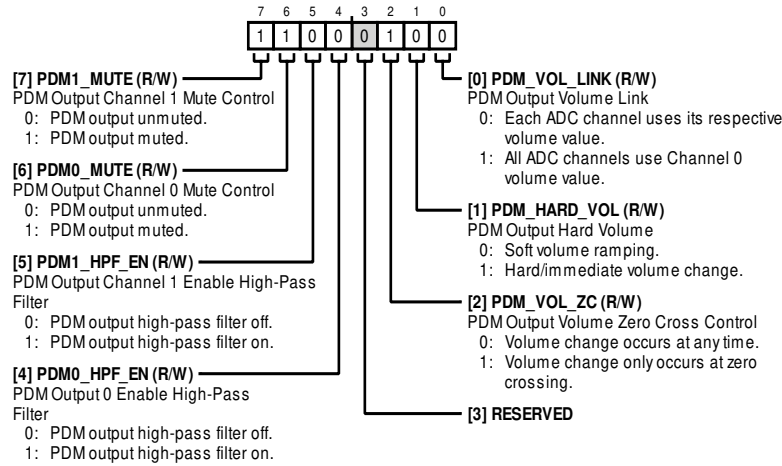

Table 224. Bit Descriptions for PDM\_CTRL2

Bits	Bit Name	Settings	Description	Reset	Access
7	PDM1_MUTE	0 1	PDM Output Channel 1 Mute Control. PDM output unmuted. PDM output muted.	0x1	R/W
6	PDM0_MUTE	0 1	PDM Output Channel 0 Mute Control. PDM output unmuted. PDM output muted.	0x1	R/W
5	PDM1_HPF_EN	0 1	PDM Output Channel 1 Enable High-Pass Filter. PDM output high-pass filter off. PDM output high-pass filter on.	0x0	R/W
4	PDM0_HPF_EN	0 1	PDM Output 0 Enable High-Pass Filter. PDM output high-pass filter off. PDM output high-pass filter on.	0x0	R/W
3	RESERVED		Reserved.	0x0	R
2	PDM_VOL_ZC	0 1	PDM Output Volume Zero Cross Control. Volume change occurs at any time. Volume change only occurs at zero crossing.	0x1	R/W
1	PDM_HARD_VOL	0 1	PDM Output Hard Volume. Soft volume ramping. Hard/immediate volume change.	0x0	R/W
0	PDM_VOL_LINK	0 1	PDM Output Volume Link. Each ADC channel uses its respective volume value. All ADC channels use Channel 0 volume value.	0x0	R/W

**PDM OUTPUT CHANNEL 0 VOLUME REGISTER**

Address: 0xC0DE, Reset: 0x40, Name: PDM\_VOL0

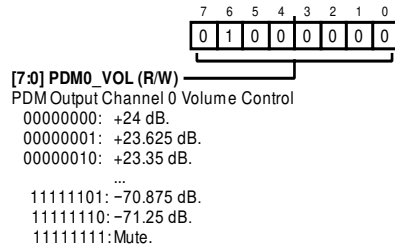
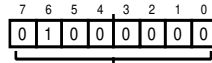

Table 225. Bit Descriptions for PDM\_VOL0

Bits	Bit Name	Settings	Description	Reset	Access
[7:0]	PDM0_VOL		PDM Output Channel 0 Volume Control.	0x40	R/W
		00000000	+24 dB.		
		00000001	+23.625 dB.		
		00000010	+23.35 dB.		
		00000011	+22.875 dB.		
		00000100	+22.5 dB.		
		...	...		
		00111111	+0.375 dB.		
		01000000	0 dB.		
		01000001	-0.375 dB.		
		...	...		
		11111101	-70.875 dB.		
		11111110	-71.25 dB.		
		11111111	Mute.		

**PDM OUTPUT CHANNEL 1 VOLUME REGISTER**

Address: 0xC0DE, Reset: 0x40, Name: PDM\_VOL1



[7:0] PDM1\_VOL (R/W)  
PDM Output Channel 1 Volume Control  
00000000: +24 dB.  
00000001: +23.625 dB.  
00000010: +23.35 dB.  
...  
11111101: -70.875 dB.  
11111110: -71.25 dB.  
11111111: Mute.

Table 226. Bit Descriptions for PDM\_VOL1

Bits	Bit Name	Settings	Description	Reset	Access
[7:0]	PDM1_VOL		PDM Output Channel 1 Volume Control.	0x40	R/W
		00000000	+24 dB.		
		00000001	+23.625 dB.		
		00000010	+23.35 dB.		
		00000011	+22.875 dB.		
		00000100	+22.5 dB.		
		...	...		
		00111111	+0.375 dB.		
		01000000	0 dB.		
		01000001	-0.375 dB.		
		...	...		
		11111101	-70.875 dB.		
		11111110	-71.25 dB.		
		11111111	Mute.		

**PDM OUTPUT CHANNEL 0 ROUTING REGISTER**

Address: 0xC0E0, Reset: 0x00, Name: PDM\_ROUTE0

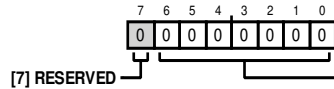

[6:0] PDM0\_ROUTE (R/W)  
PDM Output Channel 0 Input Routing  
0000000: Serial Port 0 Channel 0.  
0000001: Serial Port 0 Channel 1.  
0000010: Serial Port 0 Channel 2.  
...  
1001001: Digital Microphone Channel 1.  
1001010: Digital Microphone Channel 2.  
1001011: Digital Microphone Channel 3.

Table 227. Bit Descriptions for PDM\_ROUTE0

Bits	Bit Name	Settings	Description	Reset	Access
7	RESERVED		Reserved.	0x0	R
[6:0]	PDM0_ROUTE		PDM Output Channel 0 Input Routing.	0x0	R/W
		0000000	Serial Port 0 Channel 0.		
		0000001	Serial Port 0 Channel 1.		
		0000010	Serial Port 0 Channel 2.		
		0000011	Serial Port 0 Channel 3.		
		0000100	Serial Port 0 Channel 4.		
		0000101	Serial Port 0 Channel 5.		
		0000110	Serial Port 0 Channel 6.		
		0000111	Serial Port 0 Channel 7.		
		0001000	Serial Port 0 Channel 8.		

Bits	Bit Name	Settings	Description	Reset	Access
		0001001	Serial Port 0 Channel 9.		
		0001010	Serial Port 0 Channel 10.		
		0001011	Serial Port 0 Channel 11.		
		0001100	Serial Port 0 Channel 12.		
		0001101	Serial Port 0 Channel 13.		
		0001110	Serial Port 0 Channel 14.		
		0001111	Serial Port 0 Channel 15.		
		0100000	FastDSP Channel 0.		
		0100001	FastDSP Channel 1.		
		0100010	FastDSP Channel 2.		
		0100011	FastDSP Channel 3.		
		0100100	FastDSP Channel 4.		
		0100101	FastDSP Channel 5.		
		0100110	FastDSP Channel 6.		
		0100111	FastDSP Channel 7.		
		0101000	FastDSP Channel 8.		
		0101001	FastDSP Channel 9.		
		0101010	FastDSP Channel 10.		
		0101011	FastDSP Channel 11.		
		0101100	FastDSP Channel 12.		
		0101101	FastDSP Channel 13.		
		0101110	FastDSP Channel 14.		
		0101111	FastDSP Channel 15.		
		0110000	SigmaDSP Channel 0.		
		0110001	SigmaDSP Channel 1.		
		0110010	SigmaDSP Channel 2.		
		0110011	SigmaDSP Channel 3.		
		0110100	SigmaDSP Channel 4.		
		0110101	SigmaDSP Channel 5.		
		0110110	SigmaDSP Channel 6.		
		0110111	SigmaDSP Channel 7.		
		0111000	SigmaDSP Channel 8.		
		0111001	SigmaDSP Channel 9.		
		0111010	SigmaDSP Channel 10.		
		0111011	SigmaDSP Channel 11.		
		0111100	SigmaDSP Channel 12.		
		0111101	SigmaDSP Channel 13.		
		0111110	SigmaDSP Channel 14.		
		0111111	SigmaDSP Channel 15.		
		1000000	Input ASRC Channel 0.		
		1000001	Input ASRC Channel 1.		
		1000010	Input ASRC Channel 2.		
		1000011	Input ASRC Channel 3.		
		1000100	ADC Channel 0.		
		1000101	ADC Channel 1.		
		1001000	Digital Microphone Channel 0.		
		1001001	Digital Microphone Channel 1.		
		1001010	Digital Microphone Channel 2.		
		1001011	Digital Microphone Channel 3.		

**PDM OUTPUT CHANNEL 1 ROUTING REGISTER**

Address: 0xC0E1, Reset: 0x01, Name: PDM\_ROUTE1

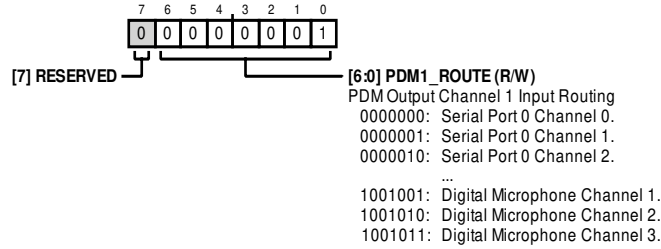

**Table 228. Bit Descriptions for PDM\_ROUTE1**

Bits	Bit Name	Settings	Description	Reset	Access
7	RESERVED		Reserved.	0x0	R
[6:0]	PDM1_ROUTE		PDM Output Channel 1 Input Routing.	0x1	R/W
		0000000	Serial Port 0 Channel 0.		
		0000001	Serial Port 0 Channel 1.		
		0000010	Serial Port 0 Channel 2.		
		0000011	Serial Port 0 Channel 3.		
		0000100	Serial Port 0 Channel 4.		
		0000101	Serial Port 0 Channel 5.		
		0000110	Serial Port 0 Channel 6.		
		0000111	Serial Port 0 Channel 7.		
		0001000	Serial Port 0 Channel 8.		
		0001001	Serial Port 0 Channel 9.		
		0001010	Serial Port 0 Channel 10.		
		0001011	Serial Port 0 Channel 11.		
		0001100	Serial Port 0 Channel 12.		
		0001101	Serial Port 0 Channel 13.		
		0001110	Serial Port 0 Channel 14.		
		0001111	Serial Port 0 Channel 15.		
		0100000	FastDSP Channel 0.		
		0100001	FastDSP Channel 1.		
		0100010	FastDSP Channel 2.		
		0100011	FastDSP Channel 3.		
		0100100	FastDSP Channel 4.		
		0100101	FastDSP Channel 5.		
		0100110	FastDSP Channel 6.		
		0100111	FastDSP Channel 7.		
		0101000	FastDSP Channel 8.		
		0101001	FastDSP Channel 9.		
		0101010	FastDSP Channel 10.		
		0101011	FastDSP Channel 11.		
		0101100	FastDSP Channel 12.		
		0101101	FastDSP Channel 13.		
		0101110	FastDSP Channel 14.		
		0101111	FastDSP Channel 15.		
		0110000	SigmaDSP Channel 0.		
		0110001	SigmaDSP Channel 1.		
		0110010	SigmaDSP Channel 2.		
		0110011	SigmaDSP Channel 3.		
		0110100	SigmaDSP Channel 4.		



Bits	Bit Name	Settings	Description	Reset	Access
		0110101	SigmaDSP Channel 5.		
		0110110	SigmaDSP Channel 6.		
		0110111	SigmaDSP Channel 7.		
		0111000	SigmaDSP Channel 8.		
		0111001	SigmaDSP Channel 9.		
		0111010	SigmaDSP Channel 10.		
		0111011	SigmaDSP Channel 11.		
		0111100	SigmaDSP Channel 12.		
		0111101	SigmaDSP Channel 13.		
		0111110	SigmaDSP Channel 14.		
		0111111	SigmaDSP Channel 15.		
		1000000	Input ASRC Channel 0.		
		1000001	Input ASRC Channel 1.		
		1000010	Input ASRC Channel 2.		
		1000011	Input ASRC Channel 3.		
		1000100	ADC Channel 0.		
		1000101	ADC Channel 1.		
		1001000	Digital Microphone Channel 0.		
		1001001	Digital Microphone Channel 1.		
		1001010	Digital Microphone Channel 2.		
		1001011	Digital Microphone Channel 3.		

OUTLINE DIMENSIONS

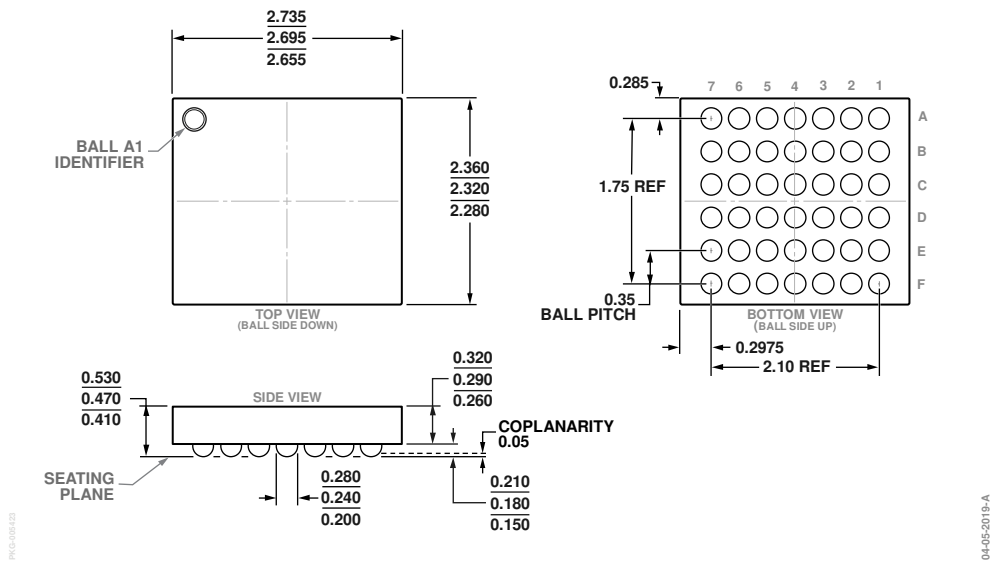

Figure 70. 42-Ball Wafer Level Chip Scale Package [WLCSP] (CB-42-2)  
Dimensions shown in millimeters

ORDERING GUIDE

Model <sup>1,2</sup>	Temperature Range	Package Description	Package Option
ADAU1788BCBZRL	-40°C to +85°C	42-Ball Wafer Level Chip Scale Package [WLCSP]	CB-42-2

<sup>1</sup> Z = RoHS Compliant Part.

<sup>2</sup> ADAU1788 uses the [EVAL-ADAU1787Z](#) evaluation board.

I<sup>2</sup>C refers to a communications protocol originally developed by Philips Semiconductors (now NXP Semiconductors).