



DM74ALS27

Triple 3-Input NOR Gate

Features

- Switching specifications at 50pF
- Switching specifications guaranteed over full temperature and V_{CC} range
- Advanced oxide-isolated, ion-implanted Schottky TTL process
- Functionally and pin for pin compatible with Schottky and low power Schottky TTL counterpart
- Improved AC performance over Schottky and low power Schottky counterparts

General Description

This device contains three independent gates, each of which performs the logic NOR function.

Ordering Information

Order Number	Package Number	Package Description
DM74ALS27M	M14A	14-Lead Small Outline Integrated Circuit (SOIC), JEDEC MS-012, 0.150" Narrow

Devices also available in Tape and Reel. Specify by appending the suffix letter "X" to the ordering number.

Connection Diagram

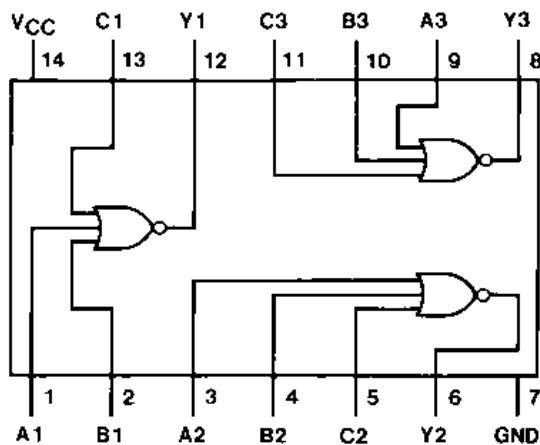

Function Table

$$Y = \overline{A + B + C}$$

Inputs			Output
A	B	C	Y
H	X	X	L
X	H	X	L
X	X	H	L
L	L	L	H

H = HIGH Logic Level

L = LOW Logic Level

X = Either LOW or HIGH Logic Level

Absolute Maximum Ratings

Stresses exceeding the absolute maximum ratings may damage the device. The device may not function or be operable above the recommended operating conditions and stressing the parts to these levels is not recommended. In addition, extended exposure to stresses above the recommended operating conditions may affect device reliability. The absolute maximum ratings are stress ratings only.

Symbol	Parameter	Rating
V_{CC}	Supply Voltage	7V
V_I	Input Voltage	7V
T_A	Operating Free Air Temperature Range	0°C to +70°C
T_{STG}	Storage Temperature Range	-65°C to +150°C
θ_{JA}	Typical Thermal Resistance	116.0°C/W

Recommended Operating Conditions

The Recommended Operating Conditions table defines the conditions for actual device operation. Recommended operating conditions are specified to ensure optimal performance to the datasheet specifications. Fairchild does not recommend exceeding them or designing to absolute maximum ratings.

Symbol	Parameter	Min.	Nom.	Max.	Units
V_{CC}	Supply Voltage	4.5	5	5.5	V
V_{IH}	HIGH Level Input Voltage	2			V
V_{IL}	LOW Level Input Voltage			0.8	V
I_{OH}	HIGH Level Output Current			-0.4	mA
I_{OL}	LOW Level Output Current			8	mA
T_A	Free Air Operating Temperature	0		70	°C

Electrical Characteristics

Over recommended operating free air temperature range. All typical values are measured at $V_{CC} = 5V$, $T_A = 25^\circ C$.

Symbol	Parameter	Conditions	Min	Typ	Max	Units
V_{IK}	Input Clamp Voltage	$V_{CC} = 4.5V$, $I_I = -18mA$			-1.5	V
V_{OH}	HIGH Level Output Voltage	$I_{OH} = -0.4mA$, $V_{CC} = 4.5V$ to $5.5V$	$V_{CC} - 2$			V
V_{OL}	LOW Level Output Voltage	$V_{CC} = 4.5V$, $I_{OL} = 8mA$		0.35	0.5	V
I_I	Input Current @ Max Input Voltage	$V_{CC} = 5.5V$, $V_{IH} = 7V$			0.1	mA
I_{IH}	HIGH Level Input Current	$V_{CC} = 5.5V$, $V_{IH} = 2.7V$			20	μA
I_{IL}	LOW Level Input Current	$V_{CC} = 5.5V$, $V_{IL} = 0.4V$			-0.1	mA
I_O	Output Drive Current	$V_{CC} = 5.5V$, $V_O = 2.25V$	-30		-112	mA
I_{CC}	Supply Current	$V_{CC} = 5.5V$	Outputs HIGH	0.97	1.8	mA
			Outputs LOW	2	4	

Switching Characteristics

Over recommended operating free air temperature range.

Symbol	Parameter	Conditions	Min.	Max.	Units
t_{PLH}	Propagation Delay Time, LOW-to-HIGH Level Output	$V_{CC} = 4.5V$ to $5.5V$,	4	15	ns
t_{PHL}	Propagation Delay Time, HIGH-to-LOW Level Output	$R_L = 500\Omega$, $C_L = 50pF$	3	9	ns

Physical Dimensions

Dimensions are in millimeters unless otherwise noted.

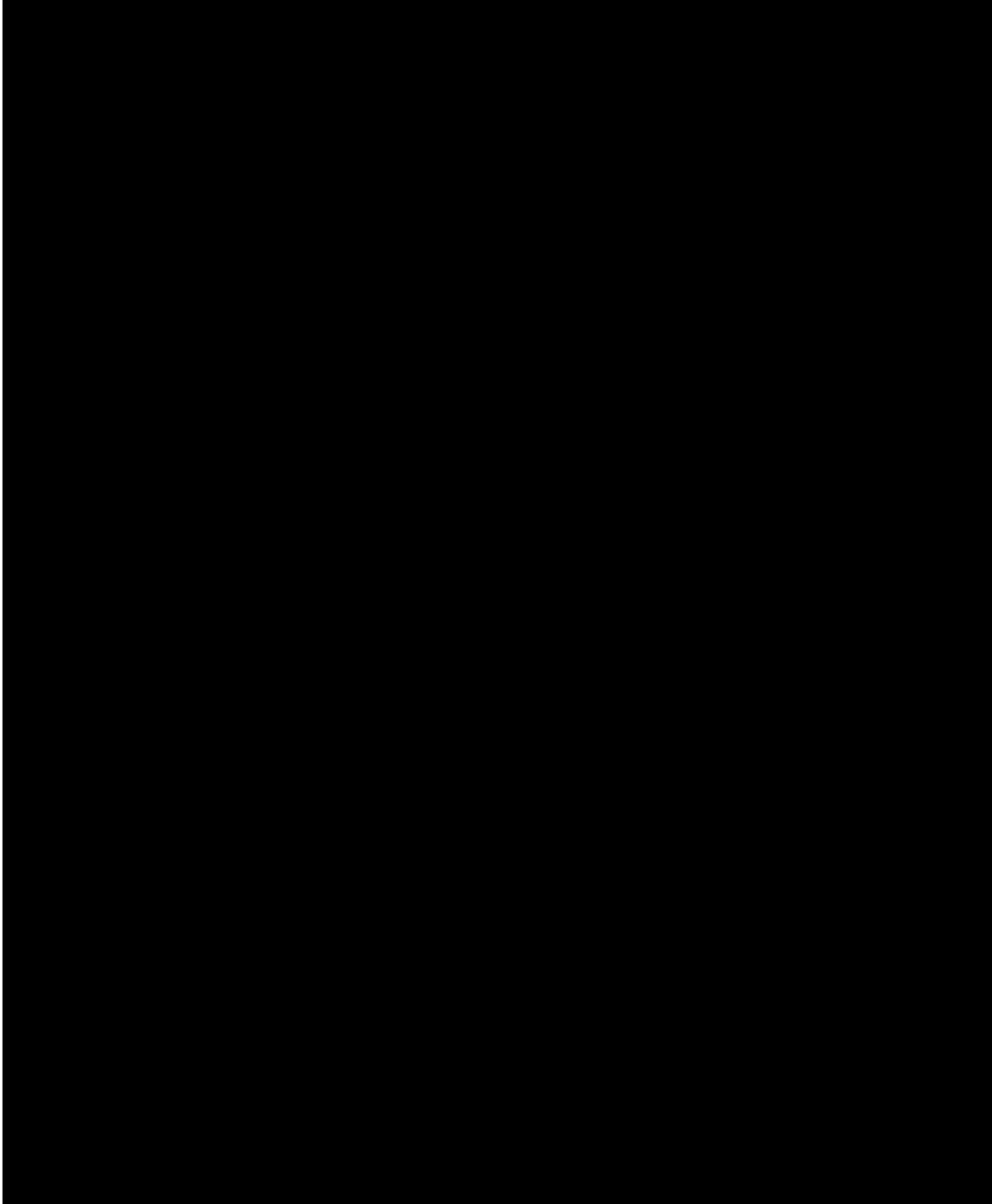

Figure 1. 14-Lead Small Outline Integrated Circuit (SOIC), JEDEC MS-012, 0.150" Narrow
Package Number M14A

