

SMT POWER INDUCTORS

Toroid Series
Ruggedized



- ⊗ Ruggedized header with SLED rails for secure board mounting
- ⊗ Current Rating: up to 3.8ADC
- ⊗ Inductance Range: 9.4μH to 439μH
- ⊗ Moisture Sensitivity Level: 1

Electrical Specifications @ 25°C – Operating Temperature – 40°C to +130°C

Part # Number	Inductance @ I _{rated} (μH)	I _{rated} (A)	DCR (mΩ)		ET (V-μsec)	Inductance @ OADC (μH ±10%)	100 Gauss ET100 (V-μsec)	1 Amp DC H1 (Orsted)
			TYP	MAX				
PL8500	9.4	3.80	27	32	15.2	10.4	2.65	11.95
PL8501	13.3	3.20	40	46	18.8	14.6	3.13	14.12
PL8502	23	2.40	65	74	24.3	25	4.10	18.46
PL8503	50	1.60	121	135	37.0	56	6.15	27.69
PL8504	75	1.30	181	220	44.3	83	7.47	33.67
PL8505	90	1.20	246	285	49.2	100	8.19	36.93
PL8506	137	1.00	387	425	59.4	152	10.12	45.61
PL8507	200	0.82	585	673	71.3	220	12.17	54.85
PL8508	305	0.66	845	972	85.8	331	14.94	67.34
PL8509	439	0.56	1322	1520	99.6	472	17.83	80.37

- NOTES:
- The reference inductance at rated DC current is a typical value.
 - Temperature rise is 50°C in typical buck or boost circuits at 250kHz and with the reference ET applied to the inductor.
 - Total loss in the inductor is 380mW for 50°C temperature rise above ambient.
 - To estimate temperature rise in a given application, determine copper and core losses, divide by 380 and multiply by 50.
 - For the copper loss, calculate $IDC^2 \times RN$.
 - For core loss, using frequency (f) and operating flux density (B), calculate $6.11 \times 10^{-18} \times B^{2.7} \times f^{2.04}$.
 - For flux density (B), calculate ET (V-μsec) for the application, divide by ET100 from the table, and multiply by 100.
 - Limit the DC bias (H) to 46 orsted. Calculate H by multiplying H1 from the table by IDC of the application.
 - Optional Tape & Reel packaging can be ordered by adding a "T" suffix to the part number (i.e. PL8500 becomes **PL8500T**).

Mechanical

Electrical Schematic

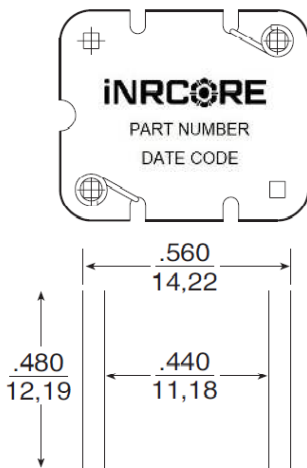

SUGGESTED PAD LAYOUT

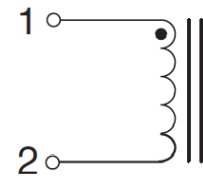
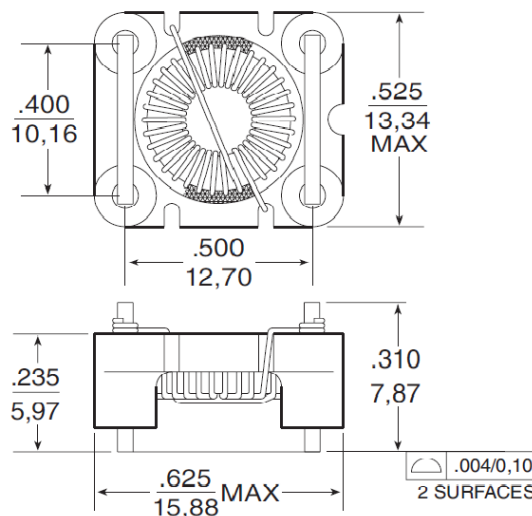

Pan & Tube35/tube
 Tape & Reel300/reel
 MSL3

Dimensions: $\frac{\text{Inches}}{\text{mm}}$

Unless otherwise specified,
 all tolerances are $\pm \frac{.010}{0,25}$



Tin/Lead Recommended Reflow Profile (Based on J-STD-020D)

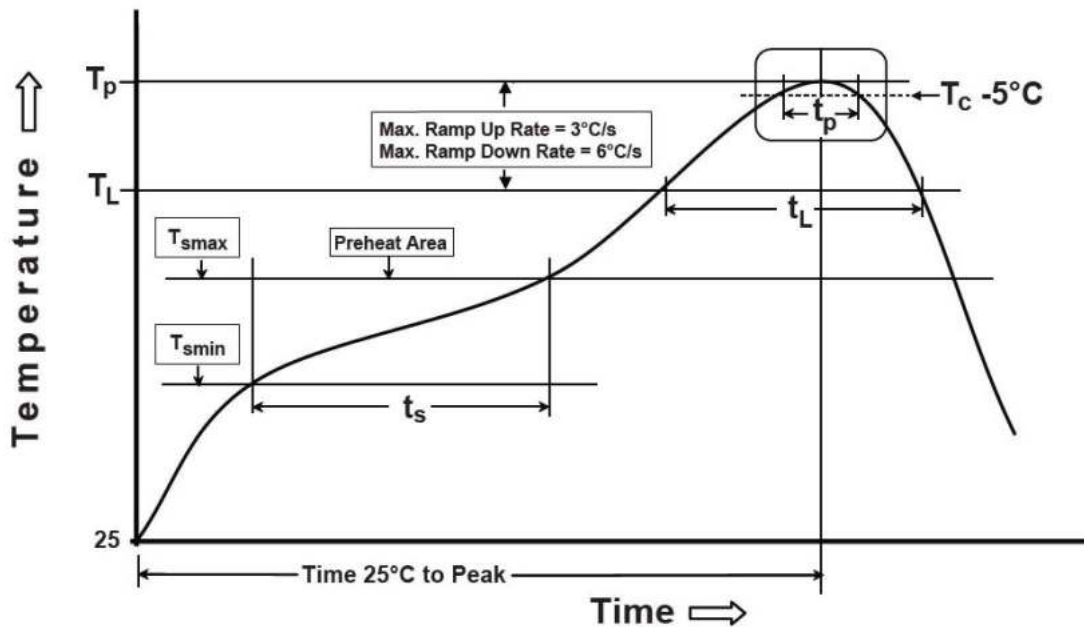

T_{SMIN} (°C)	T_{SMAX} (°C)	T_L (°C)	T_P (°C MAX)	t_s (s)	t_L (s)	t_p (s MAX)	Ramp-up rate (T_L to T_P)	Ramp-down rate (T_P to T_L)	Time 25°C to peak temperature (s MAX)
100	150	183	235	60-120	60-150	20	3°C/s MAX	6°C/s MAX	360

Notes:

1. All temperatures measured on the package leads.
2. Maximum times of reflow cycle: 2.

For More Information

iNRCORE, LLC
311 Sinclair Road Bristol,
PA 19007-6812 U.S.A
Tel: + 1.215.781.6400
Fax: +1.215.7816430

Global Sales Representatives and Locations:
<http://www.incore.com>

Performance warranty of products offered on this data sheet is limited to the parameters specified. Data is subject to change without notice. Other brand and product names mentioned herein may be trademarks or registered trademarks of their respective owners. © Copyright, 2020. iNRCORE, LLC. All rights reserved.

