

THIS DRAWING IS UNPUBLISHED. RELEASED FOR PUBLICATION 20
 © COPYRIGHT 20 BY - ALL RIGHTS RESERVED.

LOC	DIST	REVISIONS			
P	LTR	DESCRIPTION	DATE	DWN	APVD
-	-	C	REDRAWN	03JUL2012	JT YP

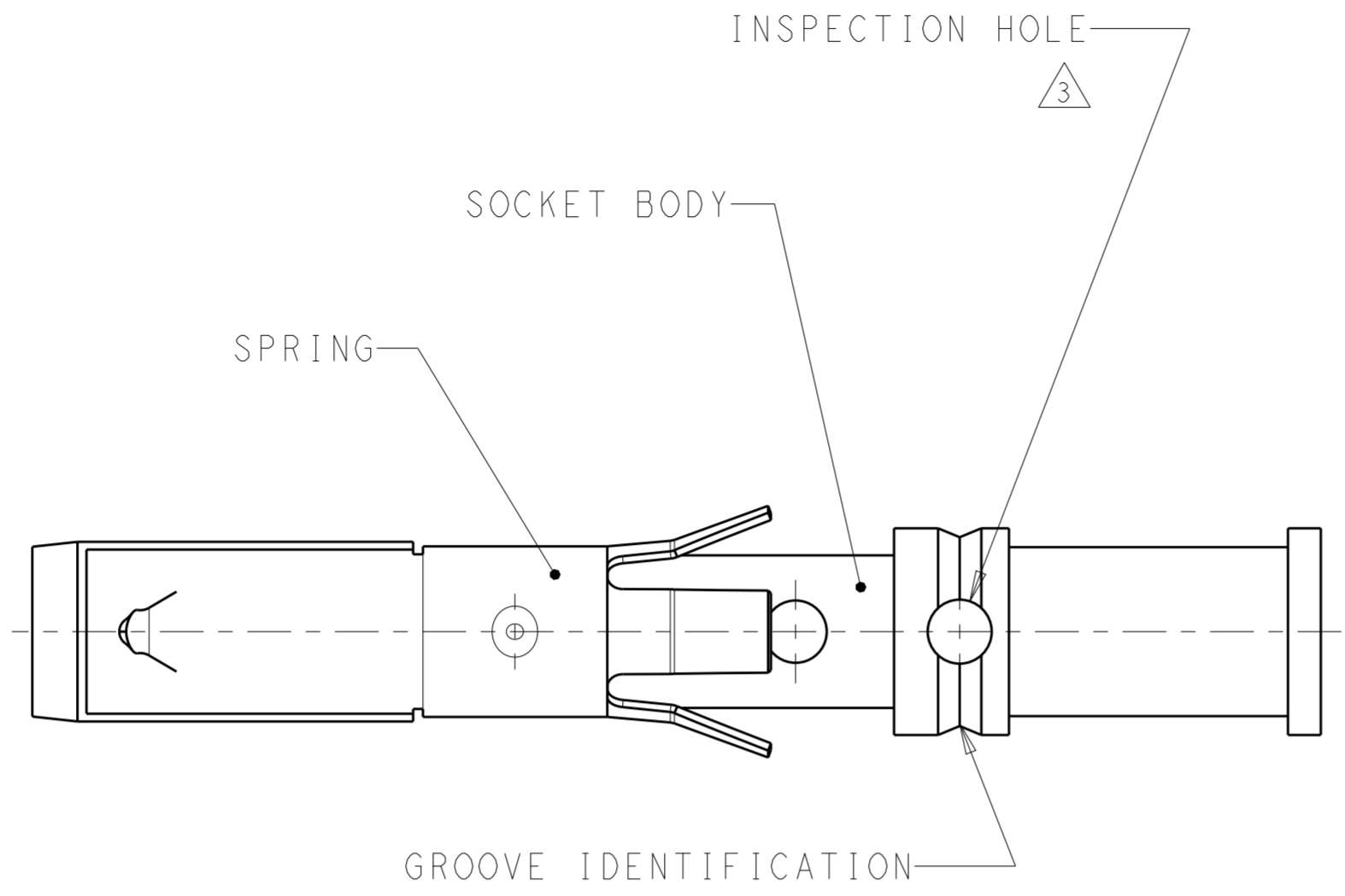

- MATERIAL:
 CONTACT BODY: COPPER ALLOY
 SPRING: STAINLESS STEEL, PASSIVATED
- FINISH:
 CONTACT BODY: GOLD OVER NICKEL
- NOT ORIENTED
- WIRE SIZE 0,30-0,89 mm² (AWG 22-18)
 CRIMP WITH TOOL : 45098 OR 91539-1

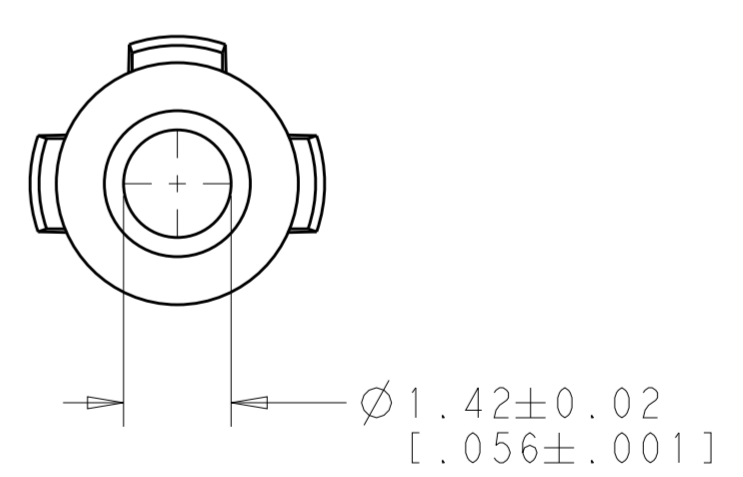
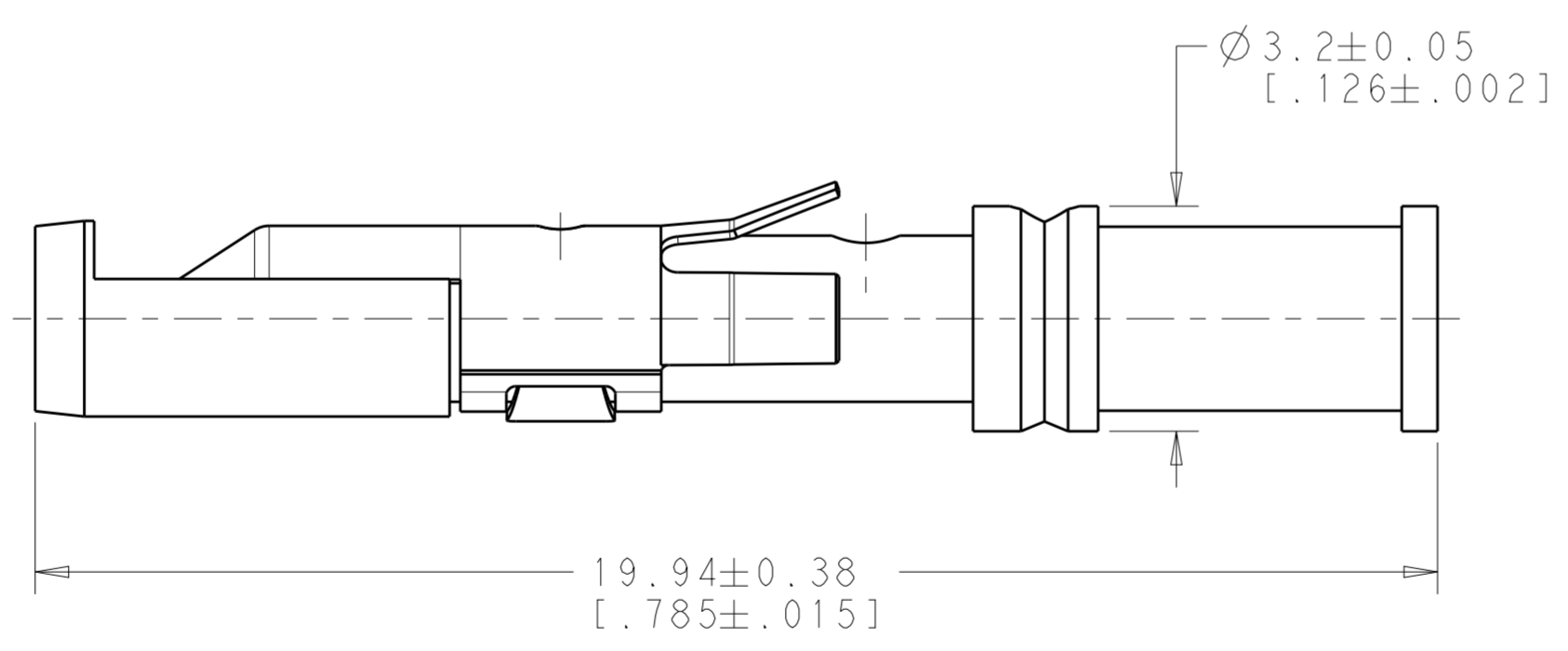
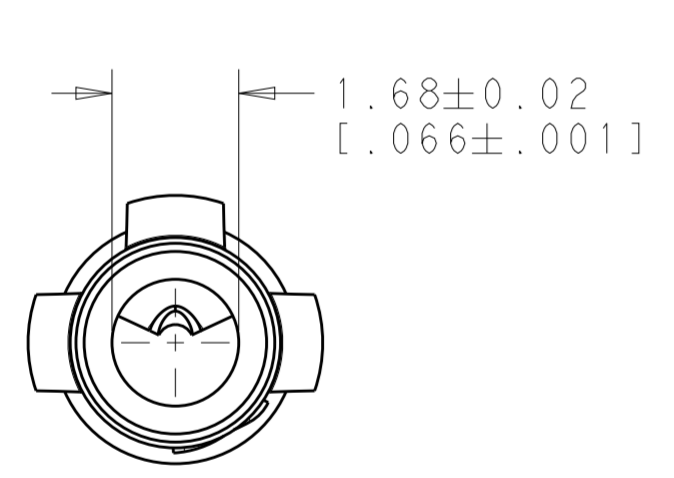

130743-1
 PART NUMBER

THIS DRAWING IS A CONTROLLED DOCUMENT.		DWN J. THUJEZ 03JUL2012	TE Connectivity	
DIMENSIONS: mm [INCHES]		CHK Y. PETRONIN 03JUL2012		
TOLERANCES UNLESS OTHERWISE SPECIFIED:		APVD Y. PETRONIN 03JUL2012	NAME CONTACT ASSEMBLY, SOCKET #16, LONG	
0 PLC ± 1 PLC ± 2 PLC ± 3 PLC ± 4 PLC ± ANGLES ± FINISH ±		PRODUCT SPEC -	RESTRICTED TO -	
MATERIAL		APPLICATION SPEC 114-10026	SIZE A200779	DRAWING NO C-130743
		WEIGHT 0.326 g	SCALE 10:1	SHEET 1 OF 1
		Customer Drawing	REV C	