

1

2

3

4

REV.	ECR/ECN No.	DESCRIPTION	DRAWN/DATE	CHECKED/DATE	APPROVED/DATE
A	ECN20200066	NEW RELEASE	Staven 2020-09-01	Staven 2020-09-01	Biao 2020-09-01

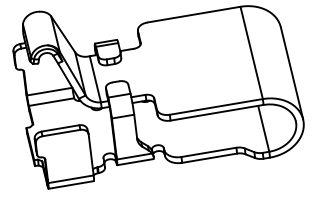
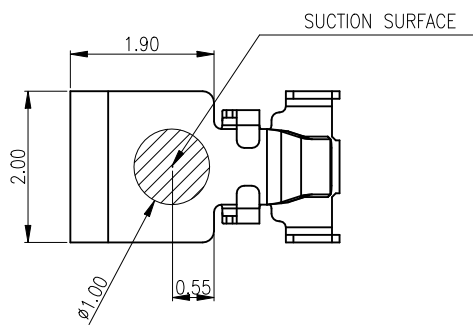

SPECIFICATIONS:

1. MATERIAL: COPPER ALLOY T=0.10mm
2. PLATING: GOLD FLASH SURFACE PLATING OVER CONTACT AREAS, GOLD FLASH SURFACE PLATING OVER SOLDER AREAS, Ni 40-120u" UNDER PLATING OVER ALL.
3. CURRENT: 3A MAX.
4. CONTACT RESISTANCE: 30mΩ MAX.

A

A

B

B

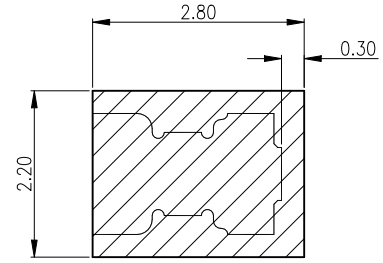
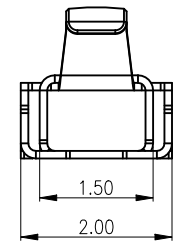
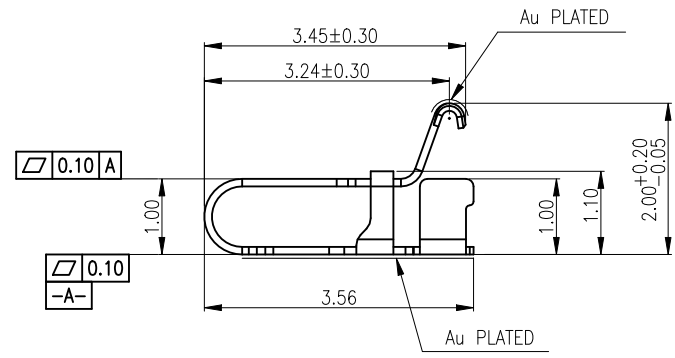

PCB LAYOUT RECOMMEND (TOP VIEW) TOLERANCE:±0.05

C

C

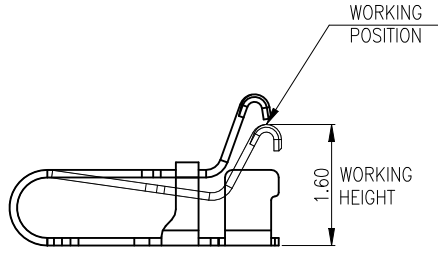
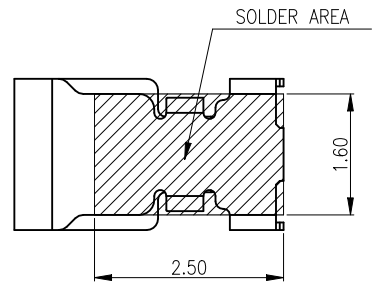

D

D

UNLESS OTHERWISE SPECIFIED TOLERANCES				ANGLE OF PROJECTION		Amphenol AORORA	
X.	±0.30	X. °	± 5'			Amphenol Aorora Technology (Huizhou) Co.,Ltd	
X.X	±0.25	X.X °	± 4'				
X.XX	±0.20	X.XX °	± 3'	Customer Drw		TITLE: H2.0mm SPRING ESD	
X.XXX	±0.15	X.XXX °	± 2'	DOC TYP	DATE	Staven	2020-09-01
LINEAR DIMS				DESIGN DATE			
ANGLES DIMS				Staven			
DWG NO.: A-S0602				CHECKED DATE			
MATERIAL SEE NOTES				Biao			
FINISHED SEE NOTES				2020-09-01			
APPROVED DATE				Biao			
2020-09-01				SIZE	PART NUMBER:	REV.	
				A4	Z02E-4F7L1-11000	A	
SCALE				1:1	UNIT : mm	SHEET 1 OF 1	

1

2

3

4

This document is the property of and embodies CONFIDENTIAL and PROPRIETARY information of AOR. No part of the information shown on this document may be used in any way or disclosed to others without the written consent of AOR. © 2019 AOR



REV.	ECR/ECN No.	DESCRIPTION	DRAWN/DATE	CHECKED/DATE	APPROVED/DATE
A	ECN20200066	INITIAL RELEASE	Staven 2020-09-01	Staven 2020-09-01	Biao 2020-09-01
B	ECN2021015	UPDATE TAPE REEL	Staven 2021-03-13	Staven 2021-03-13	Biao 2020-03-13

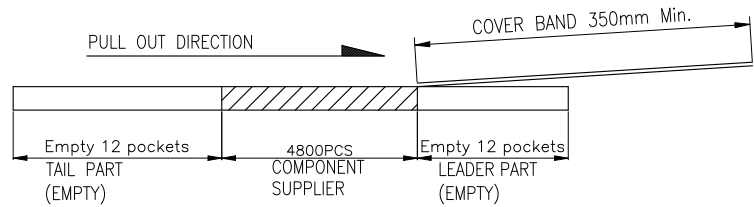
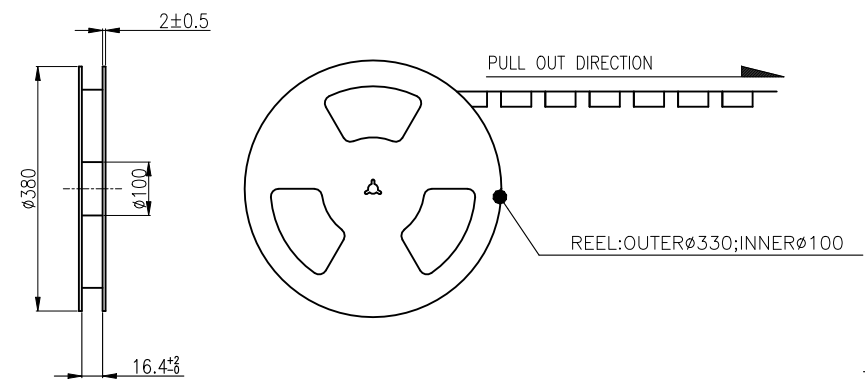
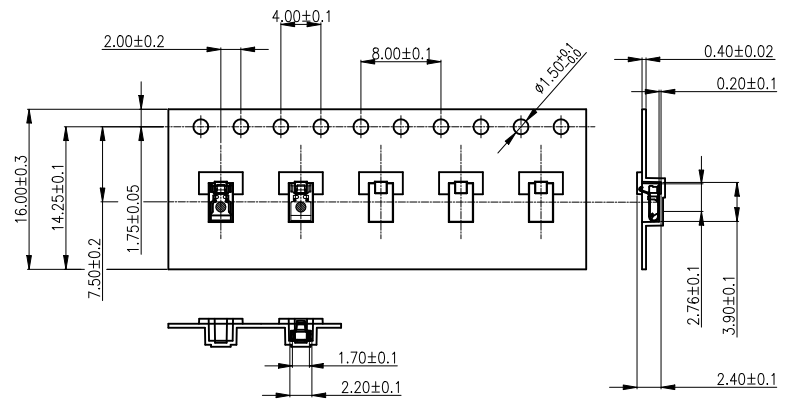

NOTES:

- MATERIAL:
 - CARRY TAPE:HIPS,T=0.40mm, COLOR:TRANSPARENT.
 - REEL:HIPS,BLUE.
 - SHIM:PET,CLEAR.
 - Protective belt:PS,CLEAR.
- PRIMARY PACKING:4800PCS/REEL.
- SECONDARY PACKING:15 REELS/CARTON ("TOTAL"=15*4800/CARTON).
- PEELING RESISTANCE: 0.2N~1.2N(20~120gf); PEELING ANGLE: 165°~180°; PEELING SPEED: 300mm/minutes.

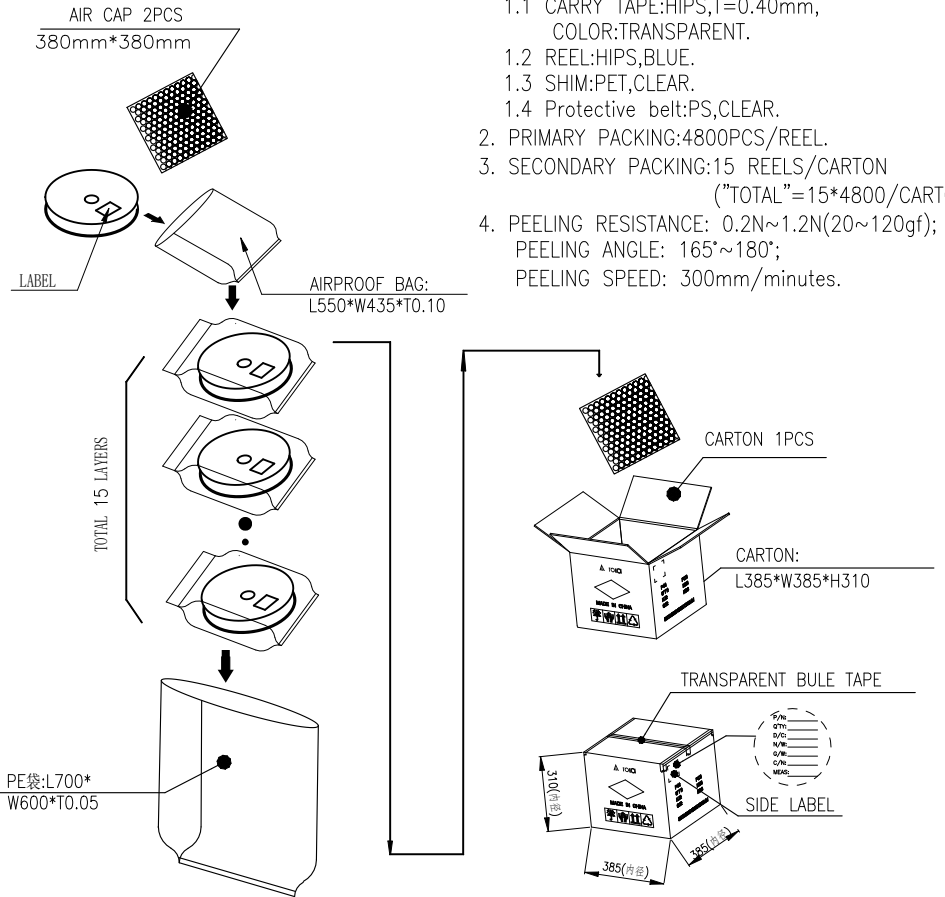

UNLESS OTHERWISE SPECIFIED TOLERANCES				ANGLE OF PROJECTION		Amphenol AORORA	
X.	±0.38	X. °	± 3'			Amphenol Aorora Technology (Huizhou) Co.,Ltd	
X.X	±0.38	X.X °	± 2'				
X.XX	±0.25	X.XX °	± 1'	DOC TYPE: Packing Drw		TITLE: SPRING H2.0-Packing	
X.XXX	±0.15	X.XXX °	± 1'	DRAWN DATE: Staven 2021-03-13	DESIGN DATE: Staven 2021-03-13	SIZE: A4	PART NUMBER: 202E-4F7L1-11000
LINEAR DIMS	ANGLES DIMS			CHECKED DATE: Biao 2021-03-13	APPROVED DATE: Biao 2021-03-13	SCALE: 1:1	UNIT: mm
DWG NO.: A-H0338	MATERIAL: SEE NOTES			FINISHED: SEE NOTES		SHEET: 1 OF 1	REV: B