

CUSTOMER: NCR/TERADATA

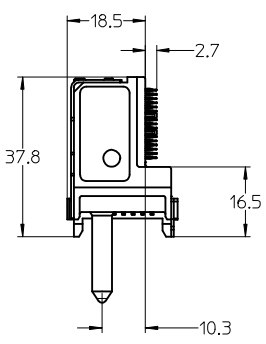
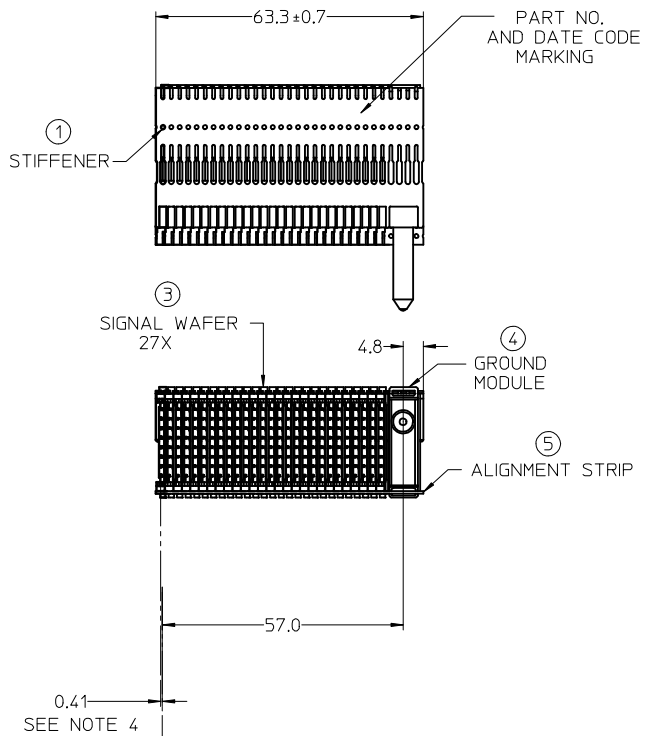
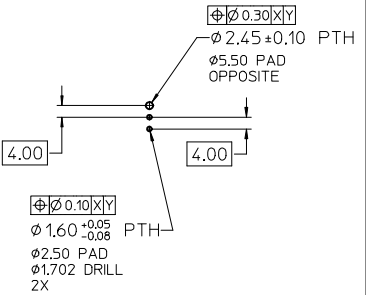
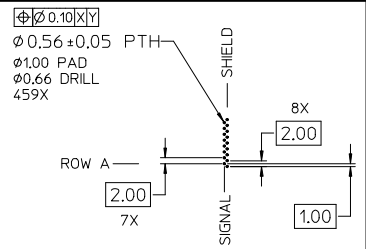

NOTES:

1. MATERIALS: HOUSING: LIQUID CRYSTAL POLYMER (LCP), GLASS-FILLED, UL94V-0, BLACK. TERMINALS: COPPER ALLOY. STIFFENER: STAINLESS STEEL.
2. FINISH: SELECTIVE GOLD (Au) IN CONTACT AREA, 0.76 MICROMETERS MINIMUM THICKNESS; SELECTIVE MATTE TIN (Sn) IN TAIL AREA; NICKEL (Ni) UNDERPLATE OVERALL.
3. THIS PART CONFORMS TO MOLEX PRODUCT SPECIFICATION PS-74031-999.
4. DISTANCE FROM CENTER OF CONTACT TO CENTER OF PLATED THROUGH HOLE.
5. PARTS PACKED PER PK-70873-0898. SCREWS PACKED IN BAGS INSIDE OF TUBES.
6. REFER TO MOLEX DOCUMENT SD-75166-001 FOR ADDITIONAL DETAILS ON SIGNAL WAFER.
7. REFER TO MOLEX DOCUMENT SD-75172-001 FOR ADDITIONAL DETAILS ON GROUND MODULES.
8. LABEL MARKED WITH MOLEX PART NUMBER AND DATE CODE. LABEL CAN BE REPLACED WITH A LASER MARK ON THE STIFFENER.
9. THIS PART CONFORMS TO MOLEX COSMETIC SPECIFICATION PS-45499-002 CLASS B.

ITEM	PART NUMBER	QTY	DESCRIPTION
1	75170-0063	1	STIFFENER
2	73774-1000	1	SEMS MACHINE SCREW
3	75166-1100	27	5.15mm SIGNAL WAFER, LF
4	75172-1000	1	GROUND MODULE
5	74719-2063	1	ALIGNMENT STRIP

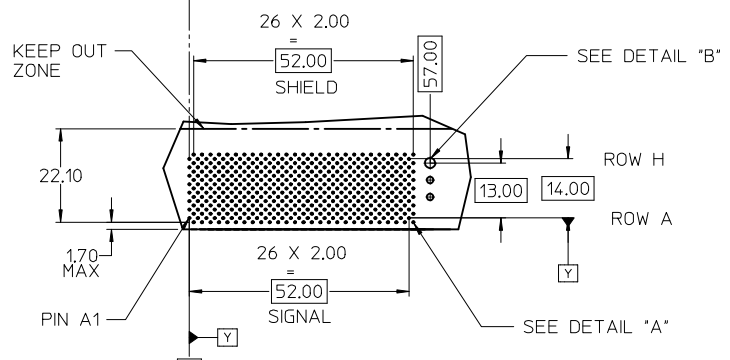

CIRCUIT BOARD HOLE PATTERN (CONNECTOR SIDE)

LEAD-FREE PLATING

CHG TO LEAD FREE IEC NO: UCP2012-2063 DRAWN BY: CHYKOWITZ CHECKED BY: APPRS: MILLER DATE: 2012/08/10	QUALITY SYMBOLS	GENERAL TOLERANCES (UNLESS SPECIFIED)	DIMENSION STYLE	SCALE	DESIGN UNITS	THIRD ANGLE PROJECTION
	▽=0	mm INCH	MM ONLY	2:1	METRIC	
	▽=0	4 PLACES ±--- ±---	DRAWN BY: JBLINGHAM	DATE: 2004/02/17	TITLE: VHDM 8 ROW, LF RIGHT ANGLE MALE SALES DRAWING	
	▽=0	3 PLACES ±--- ±---	CHECKED BY: SREED	DATE: 2004/02/17		
		ANGULAR ±1/2°	APPROVED BY: SMILLER	DATE: 2012/08/10		
		DRAFT WHERE APPLICABLE MUST REMAIN WITHIN DIMENSIONS	MATERIAL NO: 75165-1024	DOCUMENT NO: SD-75165-024		SHEET NO: 1 OF 1
			THIS DRAWING CONTAINS INFORMATION THAT IS PROPRIETARY TO MOLEX INCORPORATED AND SHOULD NOT BE USED WITHOUT WRITTEN PERMISSION			