

DO NOT SCALE FROM THIS PRINT

DESIGNED & DIMENSIONED IN MILLIMETERS [INCHES]

LSHM-1XX-XX-XXX-DH-A-X-X-XR

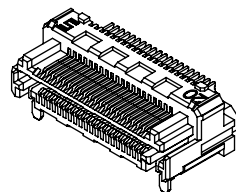
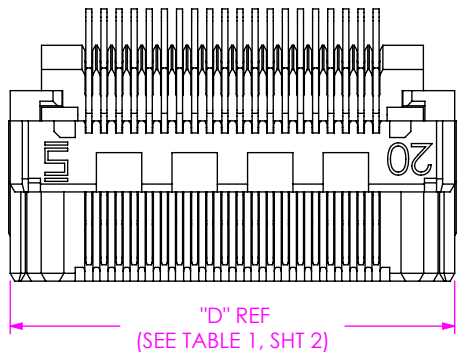

No OF POSITIONS
-05, -10, -20, -30, -40, -50

LEAD STYLE
-01: RIGHT ANGLE ONLY
-L1: LUBRICATED
(SEE TABLE 2, SHT 5)

PLATING SPECIFICATION
-L: 10µ" LIGHT SELECTIVE GOLD ON CONTACT AREA, MATTE TIN ON TAIL
-F: 3µ" FLASH SELECTIVE GOLD ON CONTACT AREA, MATTE TIN ON TAIL
-S: 30µ" FLASH SELECTIVE GOLD ON CONTACT AREA, MATTE TIN ON TAIL
-H: 30µ" HEAVY GOLD ON CONTACT AREA, 3µ" GOLD ON TAIL
-LTL: 10µ" LIGHT SELECTIVE GOLD ON CONTACT AREA, LEAD TIN ON TAIL

TAPE & REEL (SEE NOTES 6 & 9)
-TR: TAPE & REEL
-FR: FULL REEL QTY. TAPE & REEL

OPTION
-K: POLYAMIDE FILM (USE K-DOT-.177-.281-.005) (NOT AVAILABLE WITH -05 POS WHEN -N OPTION SELECTED)

SHIELD
-S: WITH SHIELD
-N: WITHOUT SHIELD

TAIL OPTION
-DH: RIGHT ANGLE

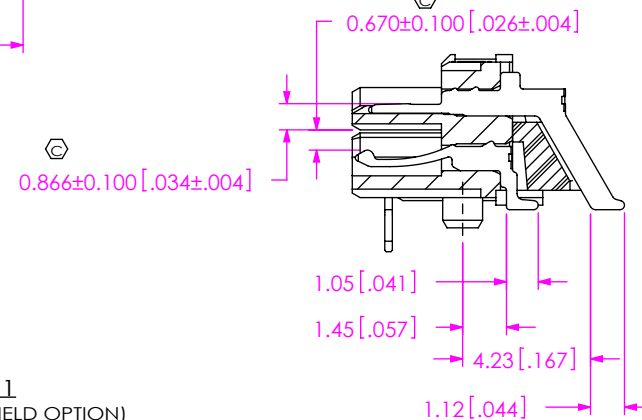
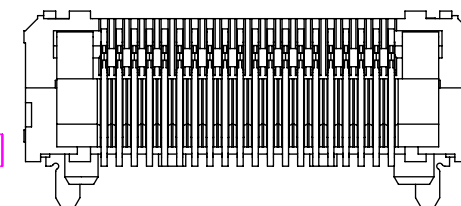
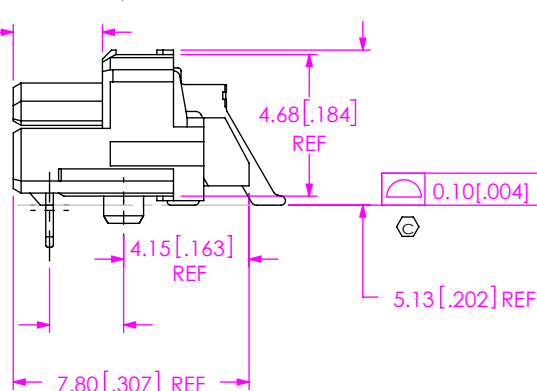
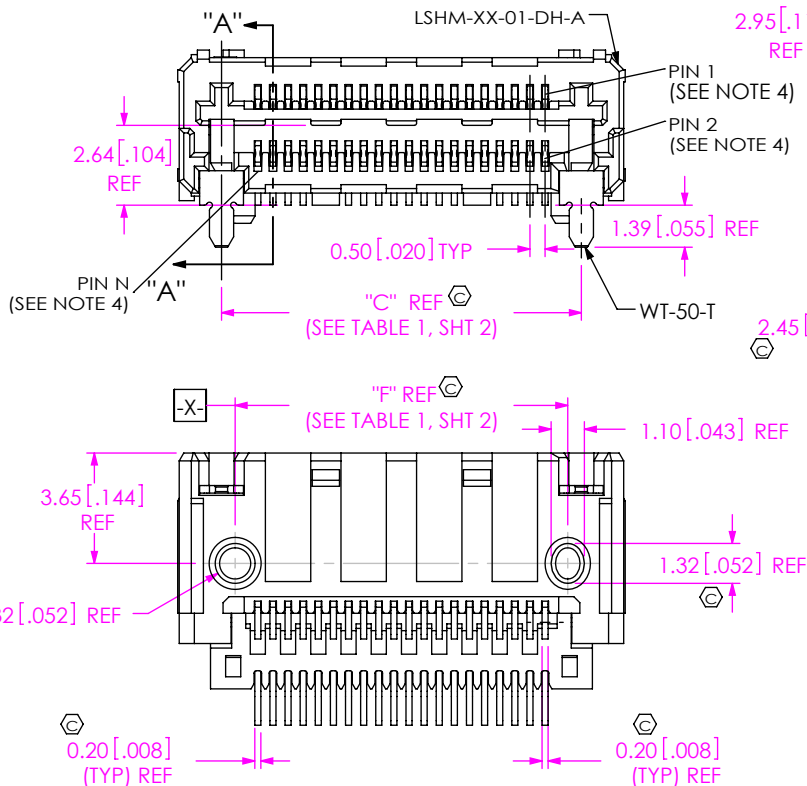

FIG 1 (WITHOUT SHIELD OPTION) LSHM-1XX-X1-XXX-DH-A-N-X-XR SHOWN

SECTION "A"-"A" SCALE 4:1

- NOTES:
1. Ⓢ REPRESENTS A CRITICAL DIMENSION.
 2. REFER TO COMPONENT PRINTS FOR MAX BURR ALLOWANCE.
 3. MINIMUM PUSHOUT FORCE: BOTH CONTACT AND WELD TAB ARE 2.22 N [.5 LBS].
 4. WHEN MATING WITH ANOTHER LSHM-DH, PIN 01 WILL MATE WITH CONTACT 02 ON MATING CONNECTOR. WHEN MATING WITH A LSHM-DV, PIN 01 WILL MATE WITH PIN N, WHERE N=TOTAL NUMBER OF POSITIONS MULTIPLY BY TWO.
 5. MEASURE FROM TOP OF VERTICAL WALL.
 6. ORDERS WILL BE PACKAGED ACCORDING TO THE SAMTEC PACKAGING EFFICIENCY STANDARDS (SPES) FOUND ON WWW.SAMTEC.COM.
 7. FOR APPLICATIONS REQUIRING TWO OR MORE CONNECTORS PER BOARD, CONTACT IPG@SAMTEC.COM.
 8. USE -Z- DATUM ZONE ONLY FOR MEASUREMENTS.
 9. ATTACH LABEL TO EACH REEL.
 10. IT NEEDS TO INSPECT BOTTOW ROW CONTACTS, TOP ROW CONTACTS, TWO WELD TAB WT-135-X.

UNLESS OTHERWISE SPECIFIED, DIMENSIONS ARE IN MILLIMETERS [INCHES]. TOLERANCES ARE:
DECIMALS ANGLES
X.X: ±0.3 [.01]
X.XX: ±0.13 [.005]
X.XXX: ±0.051 [.0020]

PROPRIETARY NOTE
THIS DOCUMENT CONTAINS CONFIDENTIAL AND PROPRIETARY INFORMATION AND ALL DESIGN, MANUFACTURING, REPRODUCTION, USE, PATENT RIGHTS AND SALES RIGHTS ARE EXPRESSLY RESERVED BY SAMTEC, INC. THIS DOCUMENT SHALL NOT BE DISCLOSED, IN WHOLE OR PART, TO ANY UNAUTHORIZED PERSON OR ENTITY NOR REPRODUCED, TRANSFERRED OR INCORPORATED IN ANY OTHER PRODUCT IN ANY MANNER WITHOUT THE EXPRESS WRITTEN CONSENT OF SAMTEC, INC.

MATERIAL: DO NOT SCALE DRAWING SHEET SCALE: 1:0.2
INSULATOR: BLACK, LCP, UL 94 V0
TERMINAL: PHOS BRONZE
SHIELD: STAINLESS STEEL
WELD TAB: COPPER

	
520 PARK EAST BLVD, NEW ALBANY, IN 47150 PHONE: 812-944-6733 FAX: 812-948-5047 e-Mail info@SAMTEC.com code 55322	
DESCRIPTION: 0.50mm TERMINAL/SOCKET COMBO	
DWG. NO. LSHM-1XX-XX-XXX-DH-A-X-X-XR	
BY: AGEN H	10/30/2008
SHEET 1 OF 5	

TABLE 1					
No OF POS	"C"	"D"	"E"	"F"	"G"
-05	4.40 [0.173]	7.20 [0.283]	7.45 [0.293]	3.50 [0.138]	1.35 [0.053]
-10	6.90 [0.272]	9.70 [0.382]	9.95 [0.392]	6.00 [0.236]	2.60 [0.102]
-20	11.90 [0.469]	14.70 [0.579]	14.95 [0.589]	11.00 [0.433]	5.10 [0.201]
-30	16.90 [0.665]	19.70 [0.776]	19.95 [0.785]	16.00 [0.630]	7.60 [0.299]
-40	21.90 [0.862]	24.70 [0.972]	24.95 [0.982]	21.00 [0.827]	10.10 [0.398]
-50	26.90 [1.059]	29.70 [1.169]	29.95 [1.179]	26.00 [1.024]	12.60 [0.496]

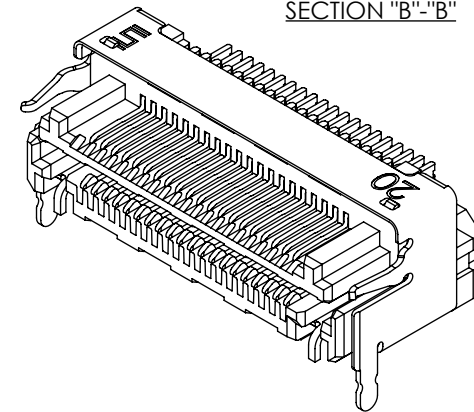
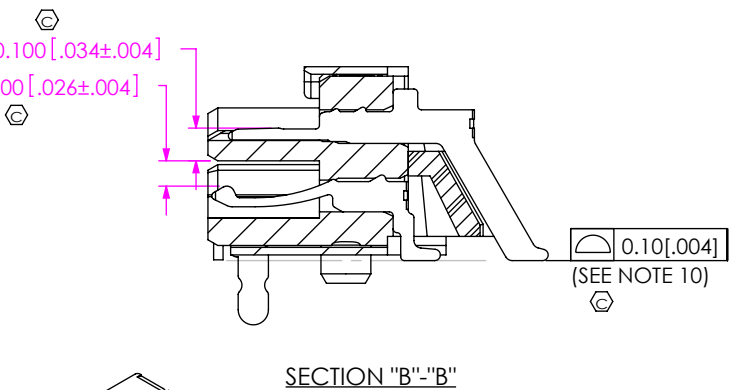
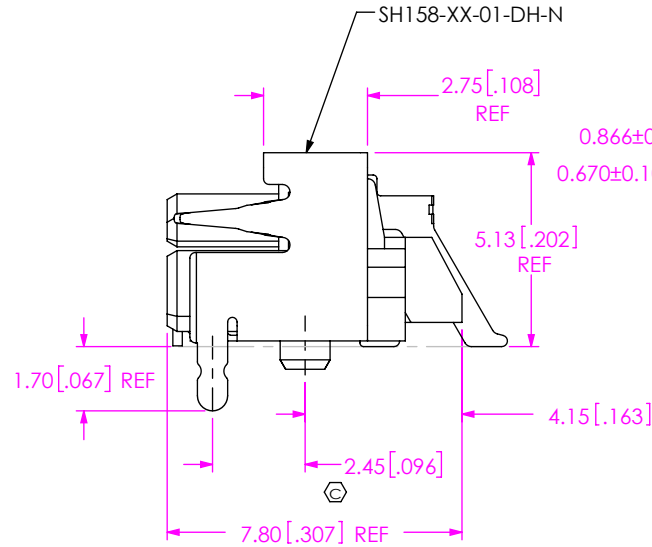
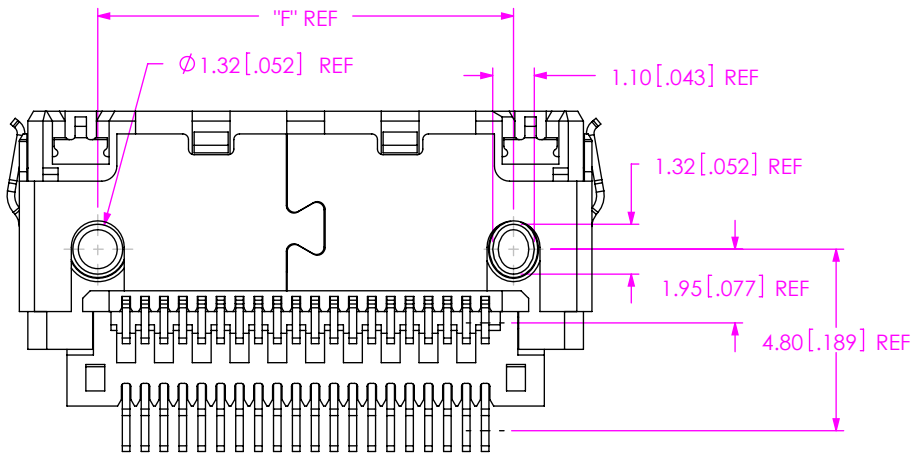
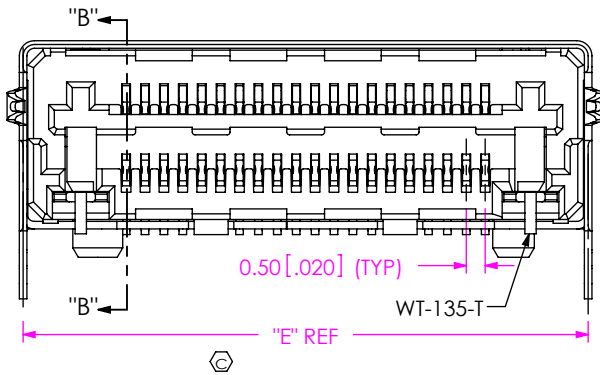
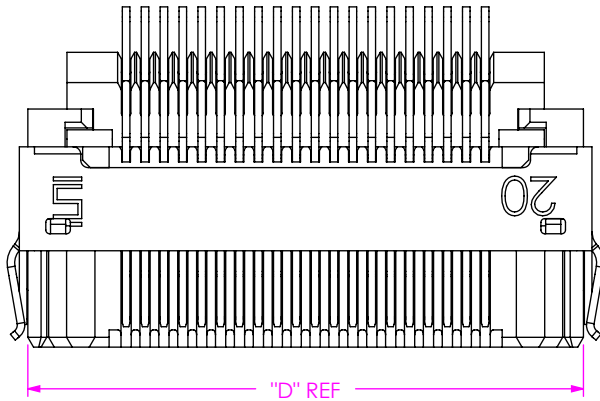

FIG 2
(SHIELD OPTION)
LSHM-1XX-X1-XXX-DH-A-S-X-XR SHOWN

PROPRIETARY NOTE
THIS DOCUMENT CONTAINS CONFIDENTIAL AND PROPRIETARY INFORMATION AND ALL DESIGN, MANUFACTURING, REPRODUCTION, USE, PATENT RIGHTS AND SALES RIGHTS ARE EXPRESSLY RESERVED BY SAMTEC, INC. THIS DOCUMENT SHALL NOT BE DISCLOSED, IN WHOLE OR PART, TO ANY UNAUTHORIZED PERSON OR ENTITY NOR REPRODUCED, TRANSFERRED OR INCORPORATED IN ANY OTHER PROJECT IN ANY MANNER WITHOUT THE EXPRESS WRITTEN CONSENT OF SAMTEC, INC.

DO NOT SCALE DRAWING
SHEET SCALE: 1:0.2

samtec

520 PARK EAST BLVD, NEW ALBANY, IN 47150
PHONE: 812-944-6733 FAX: 812-948-5047
e-Mail: info@SAMTEC.com code 55322

DESCRIPTION:
0.50mm TERMINAL/SOCKET COMBO
DWG. NO.
LSHM-1XX-XX-XXX-DH-A-X-X-XR
BY: AGEN H 10/30/2008 SHEET 2 OF 5

INSPECTION VIEW 1
(FILL BOTTOM ROW)

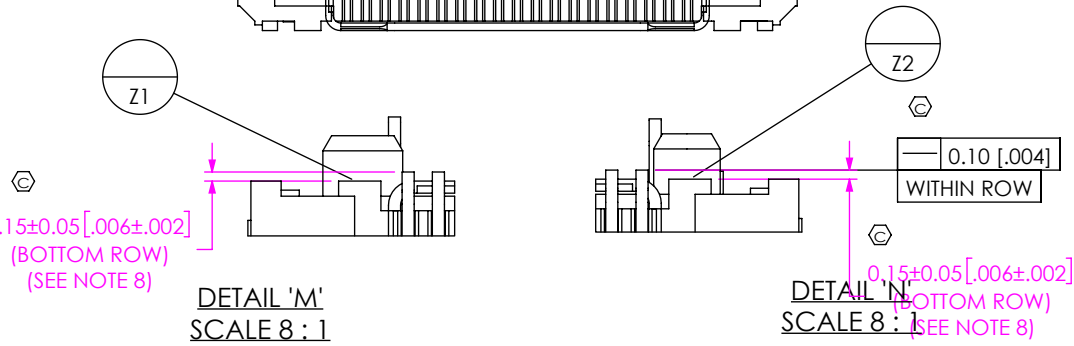
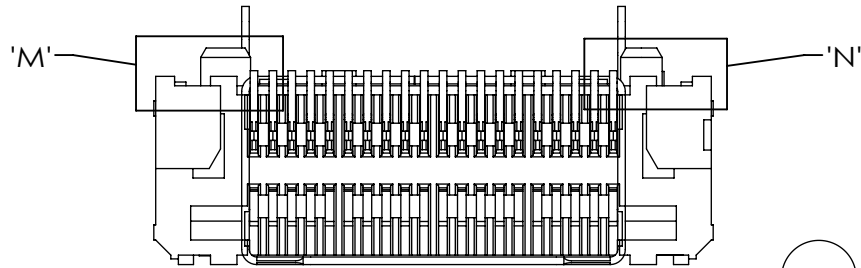
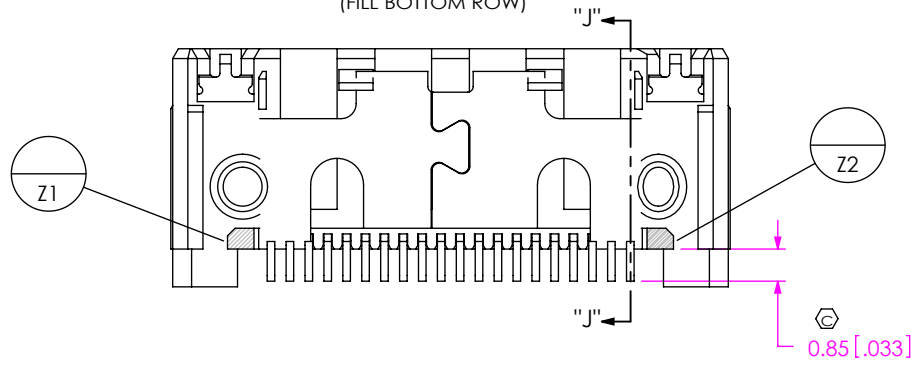

DETAIL 'M'
SCALE 8:1

DETAIL 'N'
SCALE 8:1

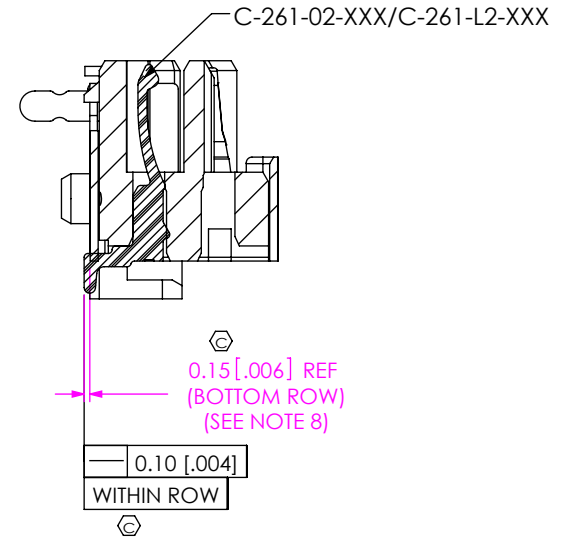

SECTION "J"

FIG 4
(IN PROCESS 1)
(SEE INSPECTION VIEW 1 FOR ORIENTATION AND CPC'S)

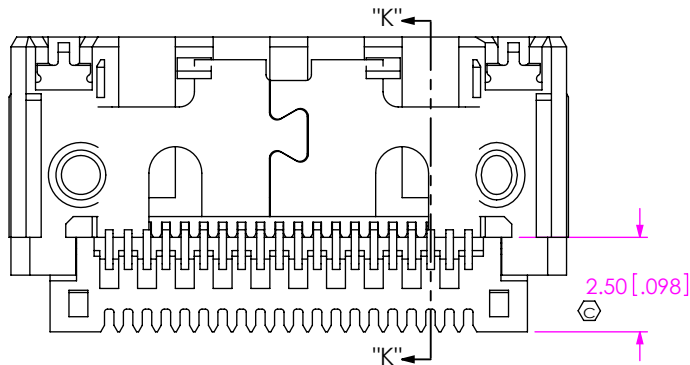
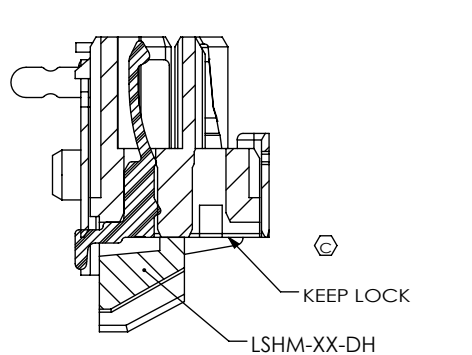

FIG 5
(IN PROCESS 2)



SECTION "K"-"K"

PROPRIETARY NOTE
THIS DOCUMENT CONTAINS CONFIDENTIAL AND PROPRIETARY INFORMATION AND ALL DESIGN, MANUFACTURING, REPRODUCTION, USE, PATENT RIGHTS AND SALES RIGHTS ARE EXPRESSLY RESERVED BY SAMTEC, INC. THIS DOCUMENT SHALL NOT BE DISCLOSED, IN WHOLE OR PART, TO ANY UNAUTHORIZED PERSON OR ENTITY NOR REPRODUCED, TRANSFERRED OR INCORPORATED IN ANY OTHER PROJECT IN ANY MANNER WITHOUT THE EXPRESS WRITTEN CONSENT OF SAMTEC, INC.



520 PARK EAST BLVD, NEW ALBANY, IN 47150
PHONE: 812-944-6733 FAX: 812-948-5047
e-Mail info@SAMTEC.com code 55322

DO NOT SCALE DRAWING
SHEET SCALE: 5:1

DESCRIPTION:
0.50mm TERMINAL/SOCKET COMBO

DWG. NO.
LSHM-1XX-XX-XXX-DH-A-X-X-XR

BY: AGEN H 10/30/2008 SHEET 3 OF 5

INSPECTION VIEW 2
(FILL TOP ROW)

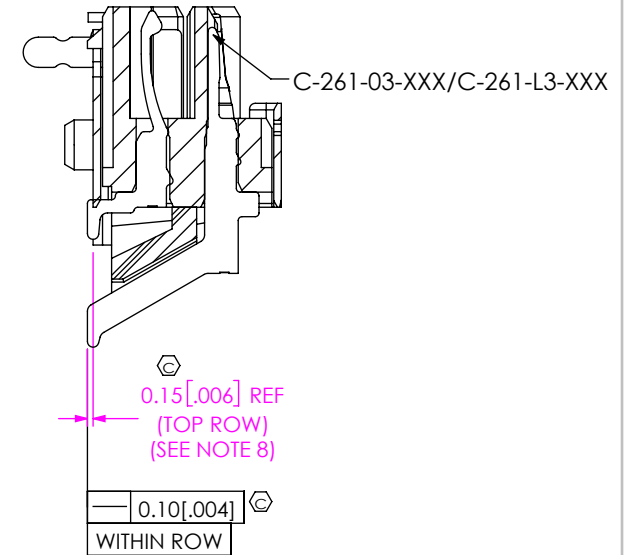
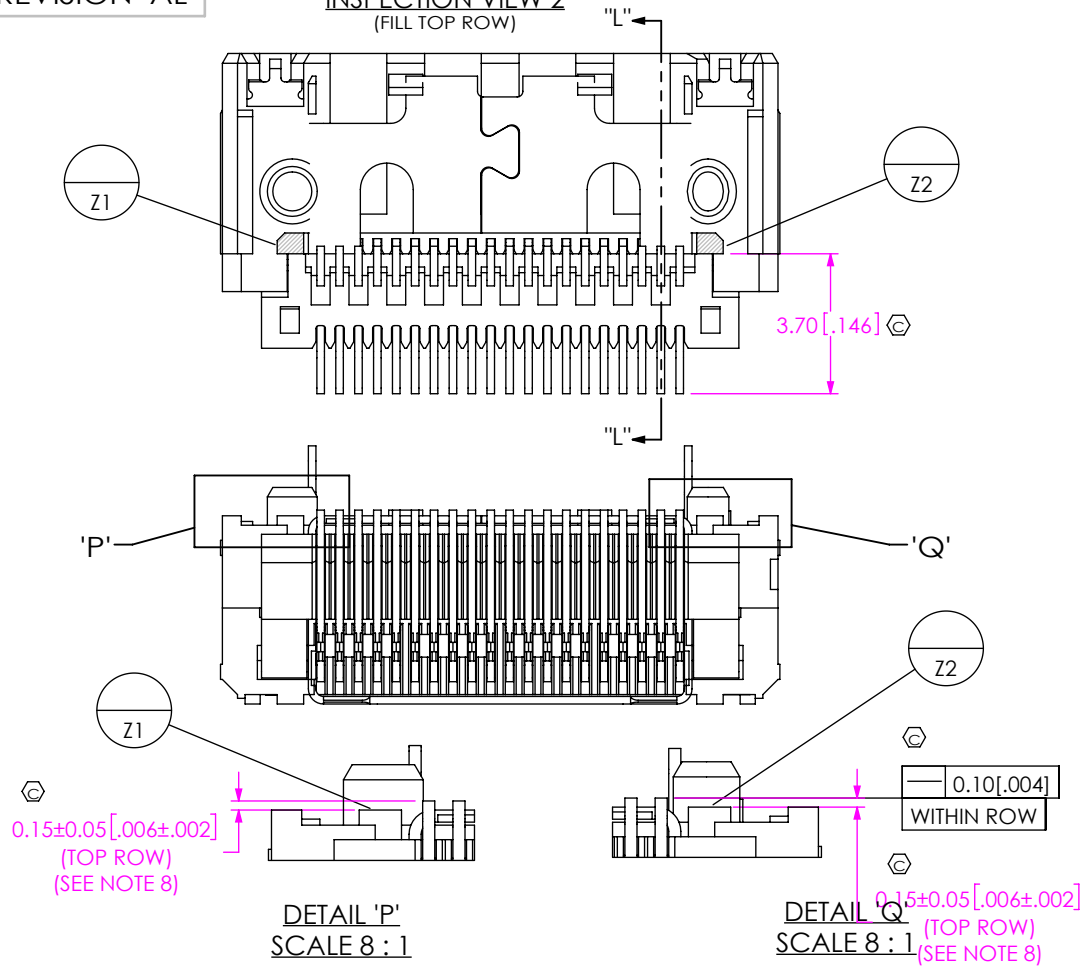

FIG 6
(IN PROCESS 3)
(SEE INSPECTION VIEW 2 FOR ORIENTATION AND CPC'S)

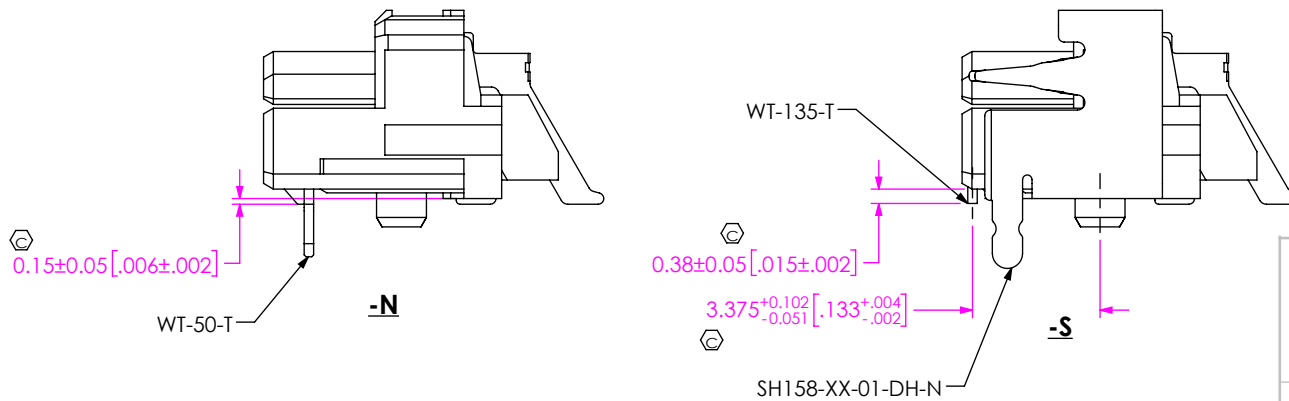

FIG 7
(IN PROCESS 4)

PROPRIETARY NOTE
 THIS DOCUMENT CONTAINS CONFIDENTIAL AND PROPRIETARY INFORMATION AND ALL DESIGN, MANUFACTURING, REPRODUCTION, USE, PATENT RIGHTS AND SALES RIGHTS ARE EXPRESSLY RESERVED BY SAMTEC, INC. THIS DOCUMENT SHALL NOT BE DISCLOSED, IN WHOLE OR PART, TO ANY UNAUTHORIZED PERSON OR ENTITY NOR REPRODUCED, TRANSFERRED OR INCORPORATED IN ANY OTHER PROJECT IN ANY MANNER WITHOUT THE EXPRESS WRITTEN CONSENT OF SAMTEC, INC.



520 PARK EAST BLVD, NEW ALBANY, IN 47150
 PHONE: 812-944-6733 FAX: 812-948-5047
 e-Mail: info@SAMTEC.com code 55322

DO NOT SCALE DRAWING
 SHEET SCALE: 5:1

DESCRIPTION:
 0.50mm TERMINAL/SOCKET COMBO

DWG. NO.
LSHM-1XX-XX-XXX-DH-A-X-X-XR

BY: AGEN H 10/30/2008 SHEET 4 OF 5

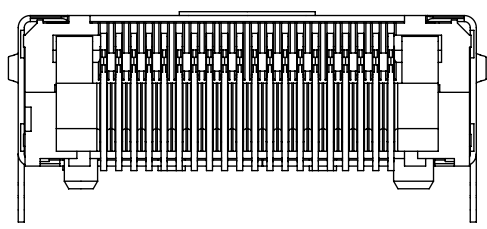
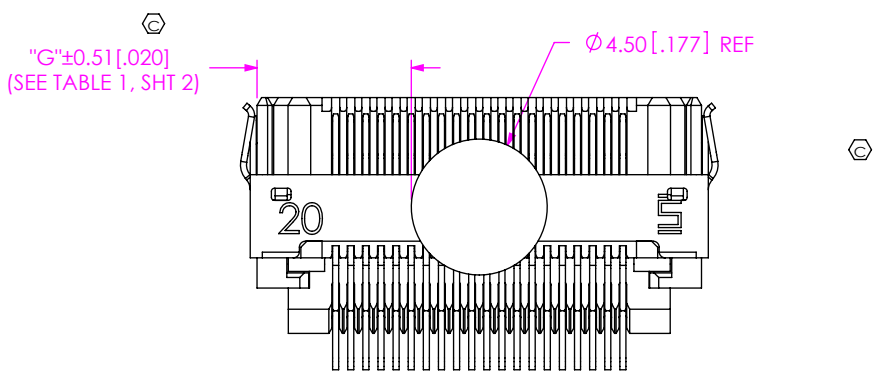

FIG 8
LSHM-1XX-X1-XXX-DH-A-S-X-XR SHOWN

TABLE 2	
LEAD STYLE	CONTACT
-01	C-261-02-XXX
	C-261-03-XXX
-L1	C-261-L2-XXX
	C-261-L3-XXX

F:\DWG\MISC\MKTG\LSHM-1XX-XX-XXX-DH-A-X-X-XR-MKT.SLDDRW

PROPRIETARY NOTE
 THIS DOCUMENT CONTAINS CONFIDENTIAL AND PROPRIETARY INFORMATION AND ALL DESIGN, MANUFACTURING, REPRODUCTION, USE, PATENT RIGHTS AND SALES RIGHTS ARE EXPRESSLY RESERVED BY SAMTEC, INC. THIS DOCUMENT SHALL NOT BE DISCLOSED, IN WHOLE OR PART, TO ANY UNAUTHORIZED PERSON OR ENTITY NOR REPRODUCED, TRANSFERRED OR INCORPORATED IN ANY OTHER PROJECT IN ANY MANNER WITHOUT THE EXPRESS WRITTEN CONSENT OF SAMTEC, INC.



520 PARK EAST BLVD, NEW ALBANY, IN 47150
 PHONE: 812-944-6733 FAX: 812-948-5047
 e-Mail info@SAMTEC.com code 55322

DO NOT SCALE DRAWING

DESCRIPTION:
 0.50mm TERMINAL/SOCKET COMBO
 DWG. NO.
 LSHM-1XX-XX-XXX-DH-A-X-X-XR
 BY: AGEN H 10/30/2008 SHEET 5 OF 5