

SMD Wire Wound Ceramic Chip Inductors IWC1008 Series

APPLICATIONS

Resonant circuits, impedance matching for

- Antenna amplifiers
- Multimedia
- Wireless communication systems

FEATURES

- High resonance frequency
- Narrow inductance tolerance
- Suitable for lead-free reflow soldering
- RoHS-compatible

MATERIAL LIST

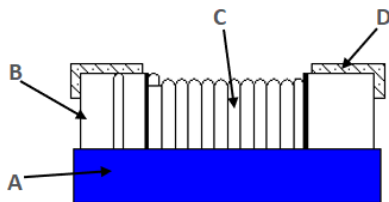

- (A) Epoxy
- (B) Ceramic
- (C) Wire
- (D) Terminal

Part Numbering

IWC	1008	D	24N	R	-3□
Product Series Code	Size Code	Rated Current Code	Inductance Value Code	Packing Code R-Tape&Reel	Additional Description
		A ≤ 100mA B=200mA C=300mA D=400mA E=500mA F=600mA G=700mA H=800mA I=900mA	0N3=0.3nH 6N8=6.8nH 24N=24nH R10=100nH		□-Tolerance Code G - ±2% J - ±5%

Notes

Standard testing conditions , unless otherwise specified

- Temperature: 15 °C to 35 °C
- Humidity: 25% to 85% (RH)
- L、 Q、 SRF : Agilent E4991A+ Agilent 16197A
- Operating Temperature: -40 °C to +125 °C
- Storage Temperature: -10 °C to +40 °C
- Products should be used within 12 months, from the time of delivery
- Cosmetic specification refer to WI-QA-124

1.SPECIFICATION

Part Number	L (nH)	Tolerance	L Test Fre (MHz)	Q Min	Q Test Fre (MHz)	DCR Max (Ω)	Rated current (mA)	SRF (MHz)
IWC1008J18NR-3G	18	2%	50	50	350	0.11	1000	2500
IWC1008J18NR-3J	18	5%	50	50	350	0.11	1000	2500
IWC1008J22NR-3G	22	2%	50	55	350	0.12	1000	2400
IWC1008J22NR-3J	22	5%	50	55	350	0.12	1000	2400
IWC1008J27NR-3G	27	2%	50	55	350	0.13	1000	1600
IWC1008J27NR-3J	27	5%	50	55	350	0.13	1000	1600
IWC1008J33NR-3G	33	2%	50	60	350	0.14	1000	1600
IWC1008J33NR-3J	33	5%	50	60	350	0.14	1000	1600
IWC1008J39NR-3G	39	2%	50	60	350	0.15	1000	1500
IWC1008J39NR-3J	39	5%	50	60	350	0.15	1000	1500
IWC1008J68NR-3G	68	2%	50	65	350	0.2	1000	1300
IWC1008J68NR-3J	68	5%	50	65	350	0.2	1000	1300
IWC1008J82NR-3G	82	2%	50	60	350	0.22	1000	1000
IWC1008J82NR-3J	82	5%	50	60	350	0.22	1000	1000
IWC1008FR10R-3G	100	2%	25	60	350	0.56	650	1000
IWC1008FR10R-3J	100	5%	25	60	350	0.56	650	1000
IWC1008FR12R-3G	120	2%	25	60	350	0.63	650	950
IWC1008FR12R-3J	120	5%	25	60	350	0.63	650	950
IWC1008FR18R-3G	180	2%	25	45	100	0.77	620	750
IWC1008FR18R-3J	180	5%	25	45	100	0.77	620	750
IWC1008ER22R-3G	220	2%	25	45	100	0.84	500	700
IWC1008ER22R-3J	220	5%	25	45	100	0.84	500	700
IWC1008ER27R-3G	270	2%	25	45	100	0.91	500	600
IWC1008ER27R-3J	270	5%	25	45	100	0.91	500	600
IWC1008DR33R-3G	330	2%	25	45	100	1.05	450	570
IWC1008DR33R-3J	330	5%	25	45	100	1.05	450	570
IWC1008DR39R-3G	390	2%	25	45	100	1.12	470	500
IWC1008DR39R-3J	390	5%	25	45	100	1.12	470	500
IWC1008DR47R-3G	470	2%	25	45	100	1.19	470	450
IWC1008DR47R-3J	470	5%	25	45	100	1.19	470	450
IWC1008DR68R-3G	680	2%	25	45	100	1.47	400	375
IWC1008DR68R-3J	680	5%	25	45	100	1.47	400	375
IWC1008DR82R-3G	820	2%	25	45	100	1.61	400	350
IWC1008DR82R-3J	820	5%	25	45	100	1.61	400	350
IWC1008C1R0R-3G	1000	2%	25	35	50	1.75	370	290
IWC1008C1R0R-3J	1000	5%	25	35	50	1.75	370	290

2. Dimensions

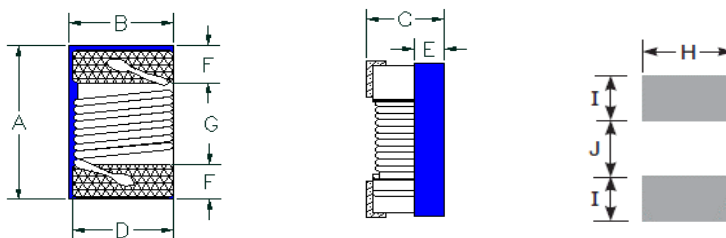

A Max	B Max	C Max	D Ref	E Ref	F Ref	G Ref	H Ref	I Ref	J Ref
2.92	2.7	2.23	2.0	1.3	0.6	1.52	2.54	1.02	1.27

3.CURVES

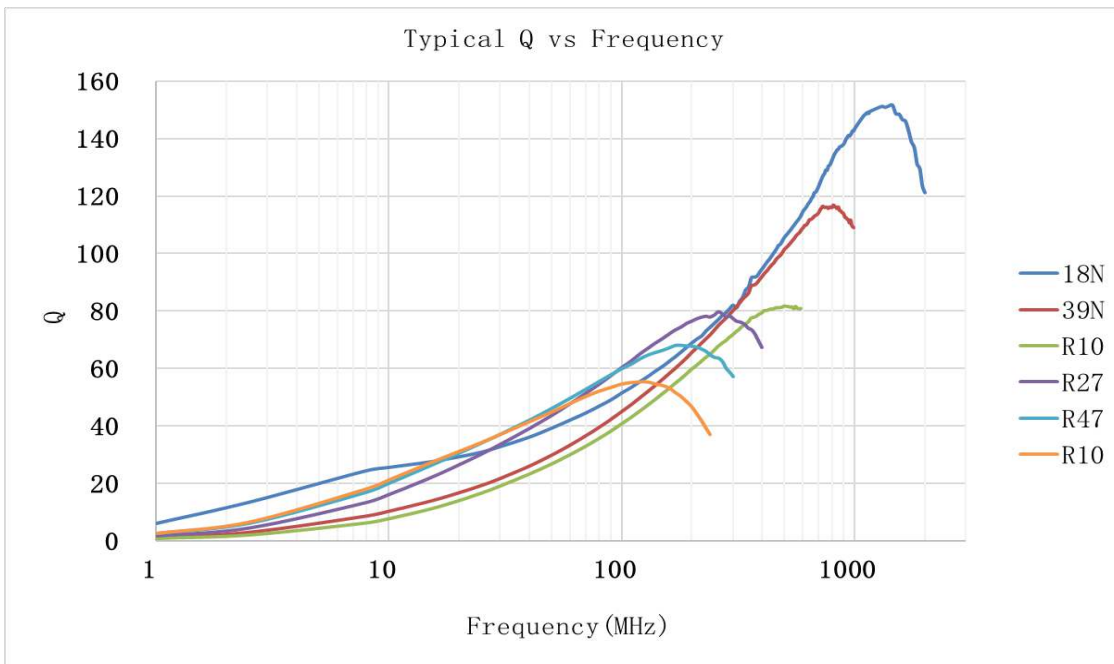
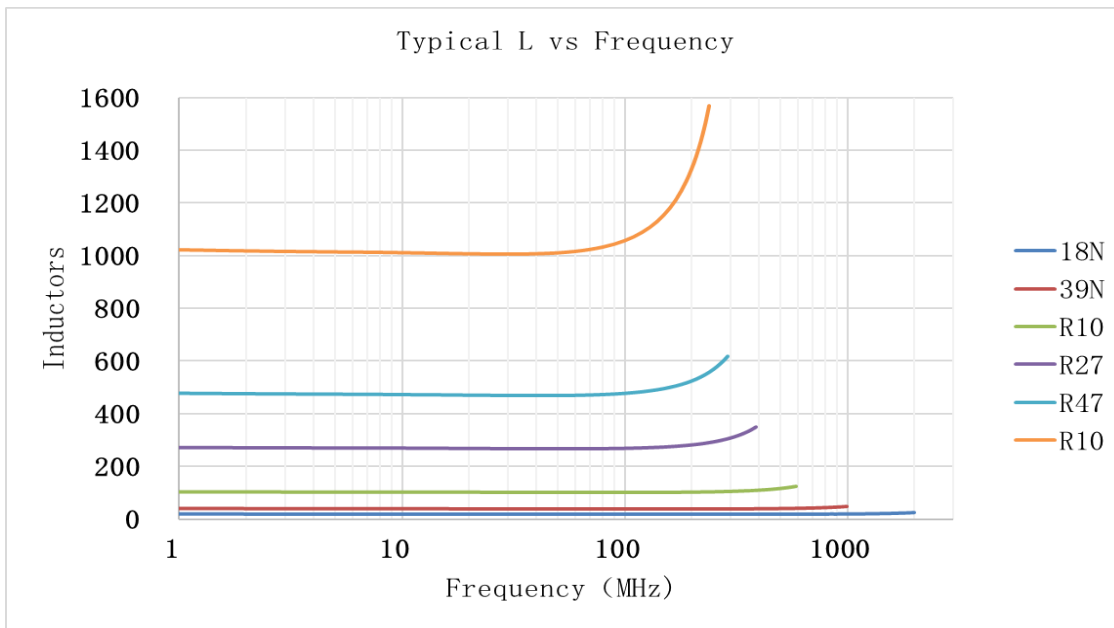

4. SOLDERING(Only reference)

Typical RoHS Reflow Profile

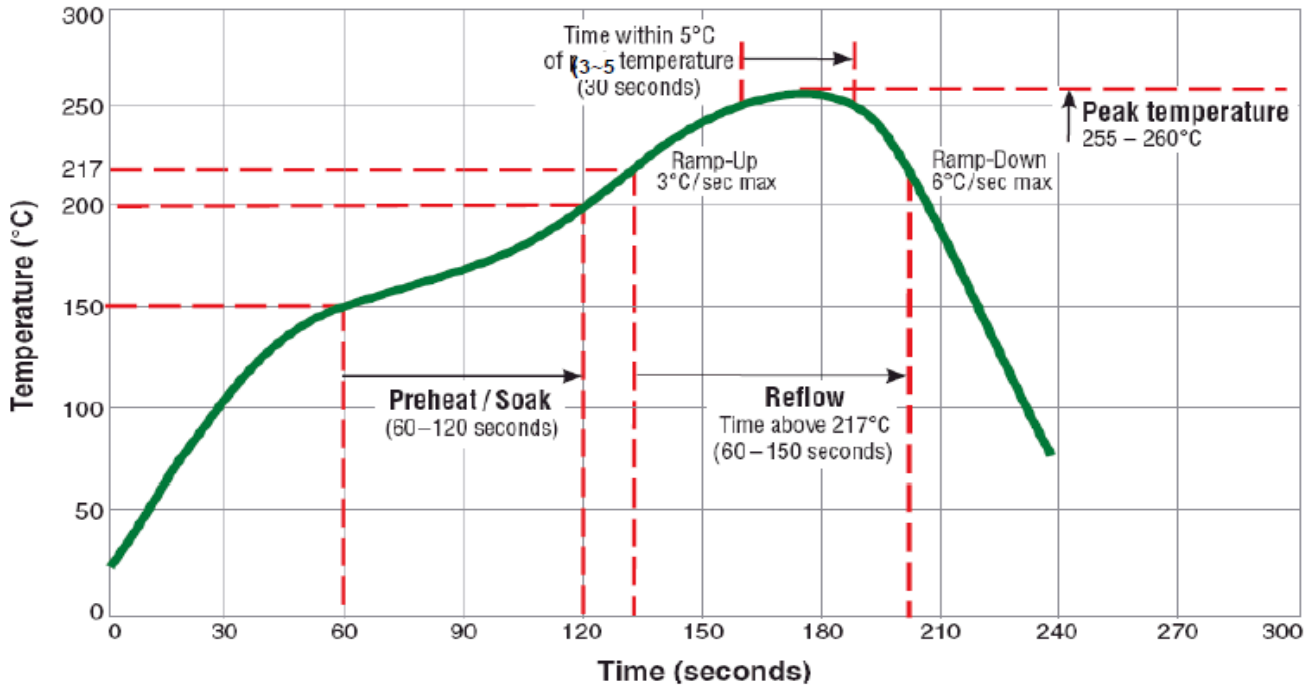

5. PACKAGING

Packaging Style and Quantity

Laird Part Number	Packaging Type	Reel Quantity	Box Quantity
IWC0805 Series	Tape & Reel	2000	10000

Taping Condition (Typ)

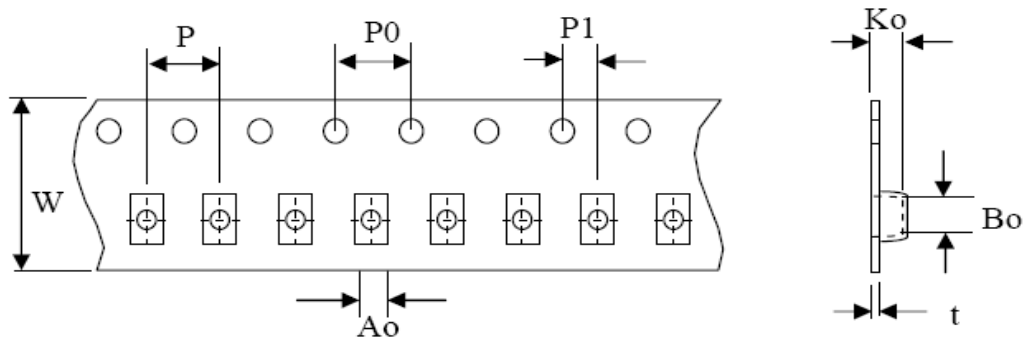

Ao	Bo	T	P	P1
2.73	2.9	0.25	4	2
W	PO	KO		
8	4	2.34		

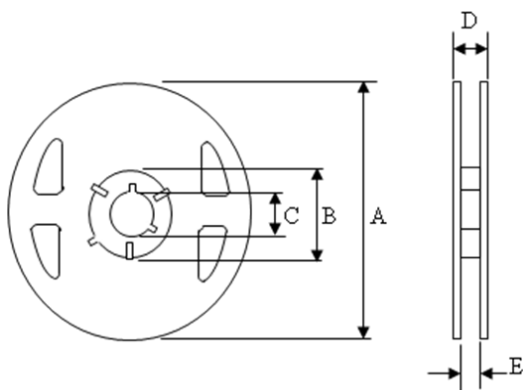

Reel Specifications (Typ)	
A	180
B	60
C	13
D	14.4
E	8.4

Tape Strength

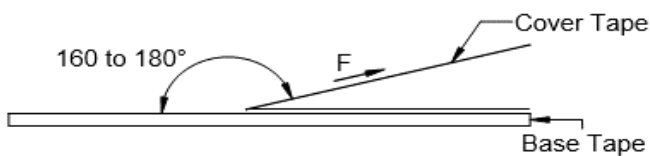

Tape Width	Peeling Force
8 mm	0.1N to 0.6N

6.RELIABILITY

No	Stress	Reference	Additional Requirements
1	High Temperature Exposure (Storage)	MIL-STD-202 Method 108	85±2°C, 168+24hours Inductance:within±10% of initial value
2	Temperature Cycling	JESD22 Method JA-104	-40°C~+85°C, 100cycles Inductance:within±10% of initial value
3	Operational Life	MIL-PRF-27	85°C(Including self-heating), 168hrs, rated current applied(as the part drawing). Inductance:within±10% of initial value
4	External Visual	MIL-STD-883 Method 2009	Inspect device construction, marking and workmanship. Electrical Test not required.
5	Physical Dimension	JESD22 Method JB-100	Verify physical dimensions to the applicable device detail specification. Note: User(s) and Suppliers spec. Electrical Test not required.
6	Vibration	MIL-STD-202 Method 204	10~55Hz,1.5mm,2 hours in each 3mutually perpendicular directions,(total of 6 hours) Inductance:within±10% of initial value
7	Resistance to Soldering Heat	MIL-STD-202 Method 210	1. Max. 260±5°C,10±1s, 2 times 2.Solder Composition: Sn/3Ag/0.5Cu
8	Solderability	J-STD-002	245±5°C, 5±1sec, Solder: Sn/3.0Ag/0.5Cu
9	Electrical Characterization	User Spec.	Parametrically test per lot and sample size requirements, summary to show Min, Max, Mean and Standard deviation at room as well as Min and Max Operating temperatures.
10	Board Flex	AEC-Q200-005	2mm(min), Dwell:30±1 sec.
11	Terminal Strength	AEC-Q200-006	Force:10N, Dwell:5+1 sec, X, Y direct