

THIS DRAWING IS UNPUBLISHED. RELEASED FOR PUBLICATION
 © COPYRIGHT - By - ALL RIGHTS RESERVED.

LOC		DIST		REVISIONS				
P	LTR	DESCRIPTION			DATE	DWN	APVD	
AD	00	K5	REVISED PER ECO-13-005565	01APR13	KH	JO		

- 11 TE TRADEMARK AND CSA LOGO ARE MOLDED INTO HOUSING.
- 12 NO PART NUMBER REQUIRED ON THIS PART.
- 13 CONTACT: 3.81-7.62µm[.000150-.000300] MATTE TIN OVER 1.27µm[.000050]MIN NICKEL
- 14 ROHS 2002/95/EC COMPLIANT

SEE SHEET 2 FOR PART NUMBERS
-51 THRU -90

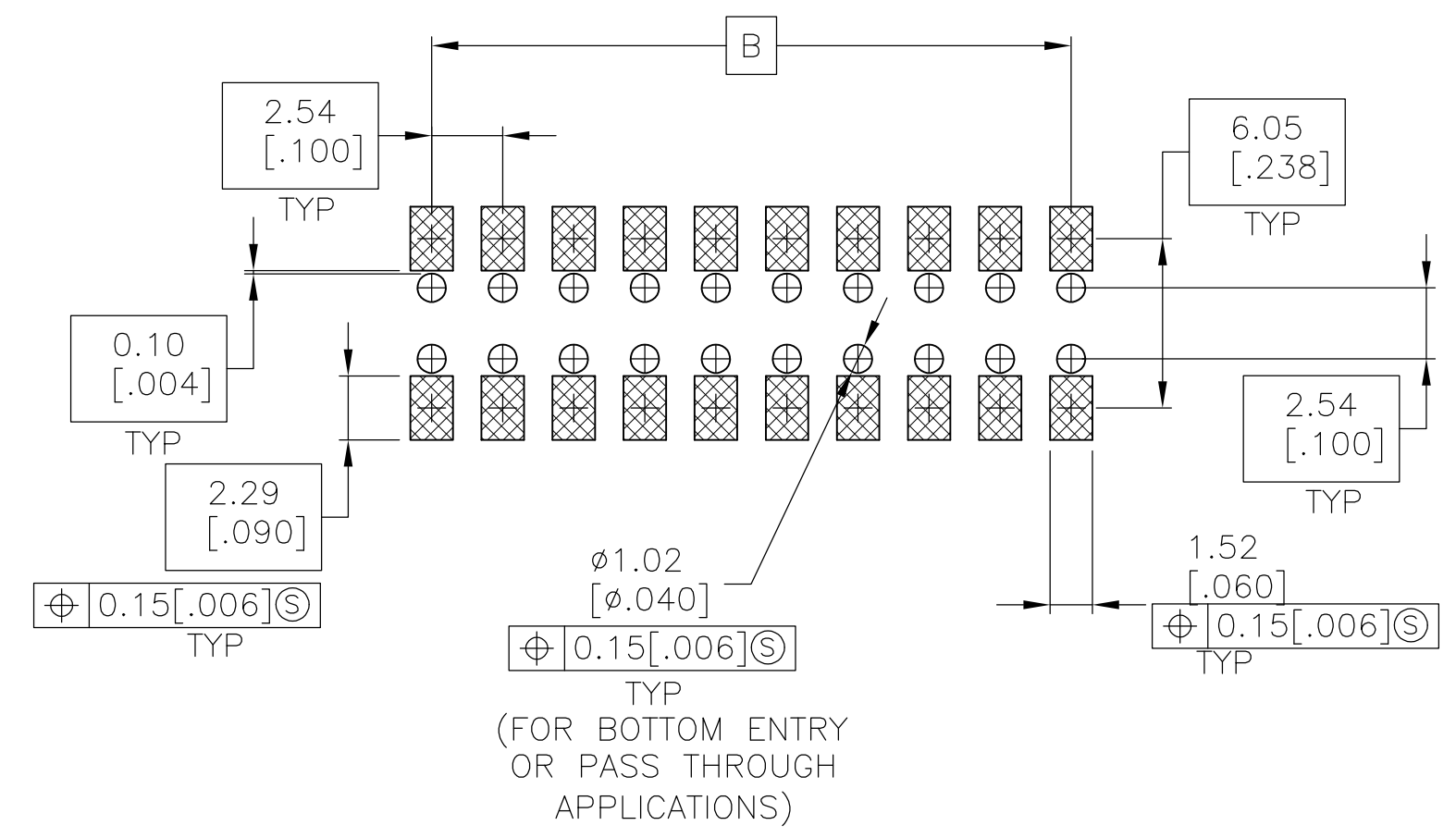
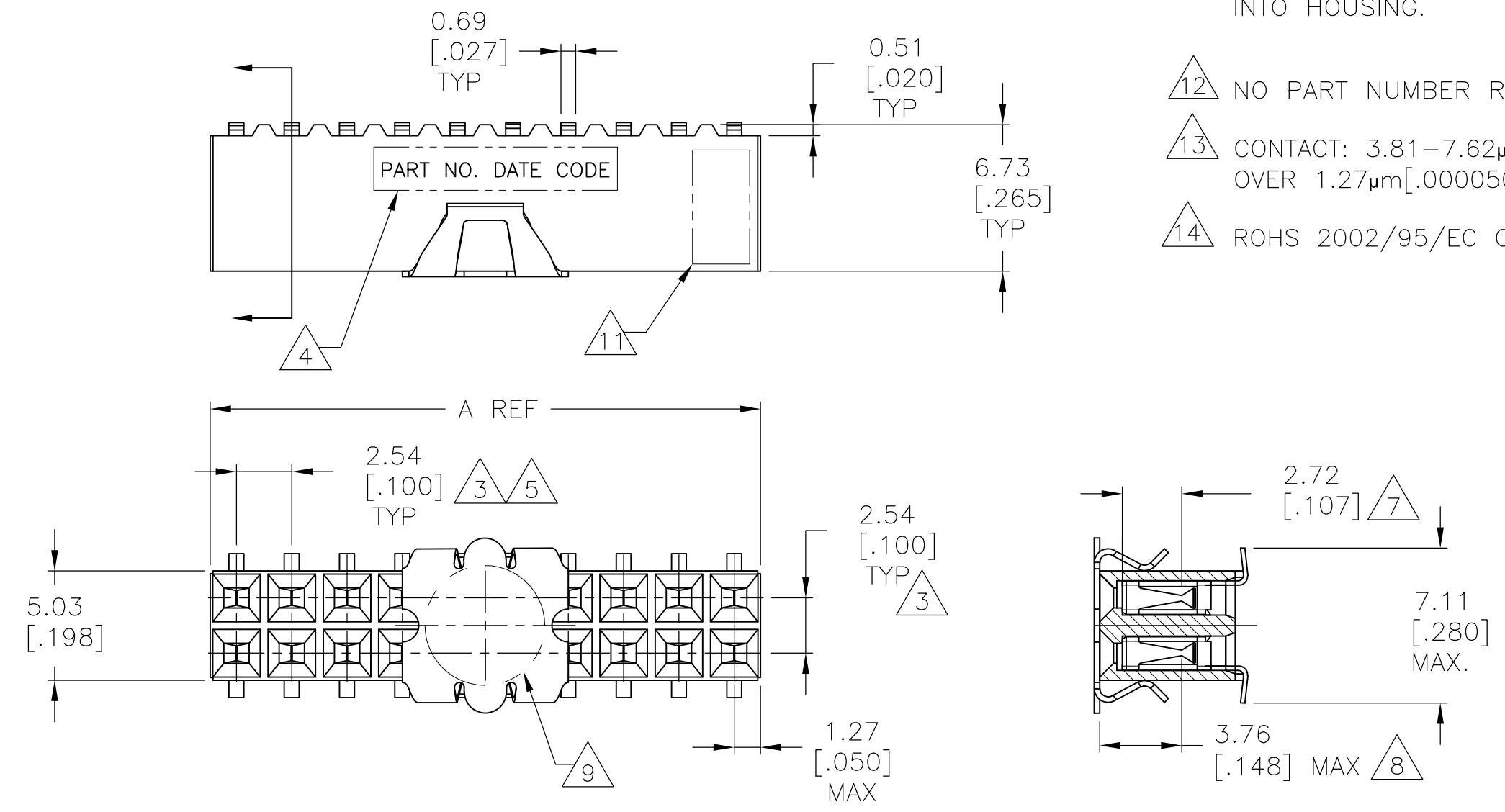

FINISH	EIA TAPE WIDTH	B	A	NO OF POSN	PART NUMBER
2	120mm	99.06[3.900]	101.60[4.000]	80	4-147106-0
		96.52[3.800]	99.06[3.900]	78	3-147106-9
		93.98[3.700]	96.52[3.800]	76	3-147106-8
		91.44[3.600]	93.98[3.700]	74	3-147106-7
		88.90[3.500]	91.44[3.600]	72	3-147106-6
		86.36[3.400]	88.90[3.500]	70	3-147106-5
		83.82[3.300]	86.36[3.400]	68	3-147106-4
		81.28[3.200]	83.82[3.300]	66	3-147106-3
		78.74[3.100]	81.28[3.200]	64	3-147106-2
		76.20[3.000]	78.74[3.100]	62	3-147106-1
		73.66[2.900]	76.20[3.000]	60	3-147106-0
		71.12[2.800]	73.66[2.900]	58	2-147106-9
		68.58[2.700]	71.12[2.800]	56	2-147106-8
		66.04[2.600]	68.58[2.700]	54	2-147106-7
		63.50[2.500]	66.04[2.600]	52	2-147106-6
		60.96[2.400]	63.50[2.500]	50	2-147106-5
		58.42[2.300]	60.96[2.400]	48	2-147106-4
		55.88[2.200]	58.42[2.300]	46	2-147106-3
		53.34[2.100]	55.88[2.200]	44	2-147106-2
		50.80[2.000]	53.34[2.100]	42	2-147106-1
		48.26[1.900]	50.80[2.000]	40	2-147106-0
		45.72[1.800]	48.26[1.900]	38	1-147106-9
		43.18[1.700]	45.72[1.800]	36	1-147106-8
		40.64[1.600]	43.18[1.700]	34	1-147106-7
38.10[1.500]	40.64[1.600]	32	1-147106-6		
35.56[1.400]	38.10[1.500]	30	1-147106-5		
33.02[1.300]	35.56[1.400]	28	1-147106-4		
30.48[1.200]	33.02[1.300]	26	1-147106-3		
27.94[1.100]	30.48[1.200]	24	1-147106-2		
25.40[1.000]	27.94[1.100]	22	1-147106-1		
22.86[.900]	25.40[1.000]	20	1-147106-0		
20.32[.800]	22.86[.900]	18	147106-9		
17.78[.700]	20.32[.800]	16	147106-8		
15.24[.600]	17.78[.700]	14	147106-7		
12.70[.500]	15.24[.600]	12	147106-6		
10.16[.400]	12.70[.500]	10	147106-5		
7.62[.300]	10.16[.400]	8	147106-4		
5.08[.200]	7.62[.300]	6	147106-3		
2.54[.100]	5.08[.200]	4	147106-2		
-	2.54[.100]	2	147106-1		

- 1 HOUSING: FLAME RETARDANT, GLASS FILLED, POLYESTER, COLOR: BLACK. CONTACT: PHOSPHOR BRONZE VACUUM COVER: STAINLESS STEEL
- 2 CONTACT: 3.81-7.62µm[.000150-.000300] BRIGHT TIN-LEAD OVER 1.27µm[.000050]MIN NICKEL
- 3 THESE DIMENSIONS PERTAIN TO CAVITY CENTERLINES ONLY NOT TO CONTACT LOCATIONS
- 4 MARK PART NUMBER AND DATE CODE IN APPROXIMATE LOCATION SHOWN, EITHER SIDE.
- 5 TOLERANCE IS NON-CUMULATIVE.
- 6 2 POSITION DATE CODE IS MARKED OPPOSITE SIDE OF TE LOGO.
- 7 POINT-OF-MEASUREMENT DIMENSION FOR PLATING THICKNESS (INSIDE CONTACT BEAM).
- 8 POINT-OF-CONTACT DIMENSION.
- 9 ø5.51[.217] MIN TARGET AREA FOR VACUUM PICK UP. COVER TO BE REMOVED AFTER SOLDERING.
- 10. PACKAGED IN TAPE & REEL PER EIA 481 SPECIFICATION.

OBSOLETE

THIS DRAWING IS A CONTROLLED DOCUMENT.

DIMENSIONS: mm [INCHES] TOLERANCES UNLESS OTHERWISE SPECIFIED:

0 PLC ± -
 1 PLC ± -
 2 PLC ± 0.13[.005]
 3 PLC ± -
 4 PLC ± -
 ANGLES ± -

MATERIAL: 1

FINISH: SEE TABLE

DWN: M.BINNER 06NOV02
 CHK: J.OLSON 06NOV02
 APVD: J.OLSON 06NOV02

PRODUCT SPEC: 108-25022
 APPLICATION SPEC: 114-25018

WEIGHT: -

CUSTOMER DRAWING

TE Connectivity

RECEPTACLE ASSEMBLY, MOD IV, DOUBLE ROW, DUAL ENTRY, .100X.100CL, SURFACE MOUNT, AMPMODU

SIZE: A2 CAGE CODE: 00779 DRAWING NO: 147106 RESTRICTED TO: -

SCALE: 4:1 SHEET: 1 OF 2 REV: K5

THIS DRAWING IS UNPUBLISHED. RELEASED FOR PUBLICATION
 © COPYRIGHT - By - ALL RIGHTS RESERVED.

LOC	DIST	REVISIONS			
P	LTR	DESCRIPTION	DATE	DWN	APVD
-	-	SEE SHEET 1	-	-	-

FINISH	EIA TAPE WIDTH	B	A	NO OF POSN	PART NUMBER
OBSOLETE	120mm	99.06 [3.900]	101.60 [4.000]	80	9-147106-0
		96.52 [3.800]	99.06 [3.900]	78	8-147106-9
		93.98 [3.700]	96.52 [3.800]	76	8-147106-8
		91.44 [3.600]	93.98 [3.700]	74	8-147106-7
		88.90 [3.500]	91.44 [3.600]	72	8-147106-6
		86.36 [3.400]	88.90 [3.500]	70	8-147106-5
		83.82 [3.300]	86.36 [3.400]	68	8-147106-4
		81.28 [3.200]	83.82 [3.300]	66	8-147106-3
		78.74 [3.100]	81.28 [3.200]	64	8-147106-2
		76.20 [3.000]	78.74 [3.100]	62	8-147106-1
		73.66 [2.900]	76.20 [3.000]	60	8-147106-0
		71.12 [2.800]	73.66 [2.900]	58	7-147106-9
	68.58 [2.700]	71.12 [2.800]	56	7-147106-8	
	88mm	66.04 [2.600]	68.58 [2.700]	54	7-147106-7
		63.50 [2.500]	66.04 [2.600]	52	7-147106-6
		60.96 [2.400]	63.50 [2.500]	50	7-147106-5
		58.42 [2.300]	60.96 [2.400]	48	7-147106-4
		55.88 [2.200]	58.42 [2.300]	46	7-147106-3
	72mm	53.34 [2.100]	55.88 [2.200]	44	7-147106-2
		50.80 [2.000]	53.34 [2.100]	42	7-147106-1
		48.26 [1.900]	50.80 [2.000]	40	7-147106-0
		45.72 [1.800]	48.26 [1.900]	38	6-147106-9
		43.18 [1.700]	45.72 [1.800]	36	6-147106-8
		40.64 [1.600]	43.18 [1.700]	34	6-147106-7
	44mm	38.10 [1.500]	40.64 [1.600]	32	6-147106-6
		35.56 [1.400]	38.10 [1.500]	30	6-147106-5
		33.02 [1.300]	35.56 [1.400]	28	6-147106-4
		30.48 [1.200]	33.02 [1.300]	26	6-147106-3
		27.94 [1.100]	30.48 [1.200]	24	6-147106-2
		25.40 [1.000]	27.94 [1.100]	22	6-147106-1
		22.86 [.900]	25.40 [1.000]	20	6-147106-0
		20.32 [.800]	22.86 [.900]	18	5-147106-9
		17.78 [.700]	20.32 [.800]	16	5-147106-8
		15.24 [.600]	17.78 [.700]	14	5-147106-7
		12.70 [.500]	15.24 [.600]	12	5-147106-6
		10.16 [.400]	12.70 [.500]	10	5-147106-5
	7.62 [.300]	10.16 [.400]	8	5-147106-4	
	5.08 [.200]	7.62 [.300]	6	5-147106-3	
	2.54 [.100]	5.08 [.200]	4	5-147106-2	
	-24mm	2.54 [.100]	2	5-147106-1	

13
14

12
12
12
12

OBSOLETE

THIS DRAWING IS A CONTROLLED DOCUMENT.		DWN M.BINNER 06NOV02	STE TE Connectivity		
DIMENSIONS: mm [INCHES]		CHK J.OLSON 06NOV02			
TOLERANCES UNLESS OTHERWISE SPECIFIED:		APVD J.OLSON 06NOV02	NAME RECEPTACLE ASSEMBLY, MOD IV, DOUBLE ROW, DUAL ENTRY, .100X.100CL, SURFACE MOUNT, AMPMODU		
0 PLC ± - 1 PLC ± - 2 PLC ± 0.13 [.005] 3 PLC ± - 4 PLC ± - ANGLES ± -		PRODUCT SPEC 108-25022	SIZE A2	CAGE CODE 00779	DRAWING NO C=147106
MATERIAL SEE TABLE		APPLICATION SPEC 114-25018	RESTRICTED TO -	SCALE 4:1	SHEET 2 OF 2
		WEIGHT -	REV K5		
		CUSTOMER DRAWING			