



# FMT1000-series Motion Tracking Module with Output of Orientation, Inertial Motion Data and Magnetic Field

## Features

- Complete module providing many user-configurable outputs
- Incorporates Fairchild’s highly accurate Inertial Measurement Unit FIS1100
- Roll/Pitch Accuracy (Dynamic): 3.0 deg
- Heading Accuracy: 3.0 deg
- Minimal requirements on host processor
- No knowledge of inertial sensors signal processing required for best performance
- Industry-leading signal processing pipeline (AttitudeEngine™) with vibration-rejection
- Short time to market with turn-key solution
- Drivers and examples on ARM® mbed™
- Low Power (45 mW at 3.0 V)
- PLCC28-compatible PCB (12.1 x 12.1 x 2.6 mm)

## Applications

- Light Industrial and Robotics
- VR/AR
- GNSS Augmentation and Dead Reckoning
- Agriculture and Heavy Machinery
- Miniature Aerial Vehicles (Drones)
- Image Stabilization and Platform Stabilization
- Pedestrian Dead-Reckoning

## Related Resources

- [FMT1000 Product Folder](#)
- FEBFMT1030 User Guide
- FCS MT Manager User Guide
- FCS MFM User Guide

## Description

The FMT1000-series is a product group of turn-key industrial grade Motion Tracker modules intended for integration of motion intelligence on unmanned systems, heavy industry, machine automation and agriculture.

With output of 3D orientation, 3D rate of turn, 3D accelerations, and 3D magnetic field directly from the module, the FMT1000-series can be integrated with minimal hardware and software development. The output is configurable in terms of data selection, output format, output data rate and communication protocol, reducing the load on the host processor.

The high data rates of up to 1 kHz and orientation accuracy of 3.0° RMS makes it an excellent choice for applications in control and stabilization, and navigation e.g. unmanned vehicles.

Calibration and testing has already been performed on each individual unit ensuring high quality of the product delivered and its performance.

The FMT1000-series has three products (see below) with distinctive capabilities and outputs.

Product Output	FMT1010 IMU	FMT1020 VRU	FMT1030 AHRS
Motion Data	•	•	•
Magnetic Field	•	•	•
Roll/Pitch		•	•
Heading Tracking		•	•
Referenced Yaw			•



Figure 1. FMT1000-series Module

# Table of Contents

<b>1</b>	<b>General Information.....</b>	<b>3</b>
1.1	ORDERING INFORMATION.....	3
1.2	BLOCK DIAGRAM .....	3
1.3	TYPICAL APPLICATION .....	4
1.4	PIN CONFIGURATION.....	4
1.5	PIN MAP.....	5
1.6	PIN DESCRIPTIONS .....	6
1.7	PERIPHERAL INTERFACE SELECTION.....	7
1.7.1	<i>Peripheral Interface Architecture.....</i>	<i>7</i>
1.7.2	<i>Xbus Protocol.....</i>	<i>8</i>
1.7.3	<i>MTSSP Synchronous Serial Protocol.....</i>	<i>8</i>
1.7.4	<i>I<sup>2</sup>C.....</i>	<i>11</i>
1.7.5	<i>SPI.....</i>	<i>12</i>
1.7.6	<i>UART Half Duplex.....</i>	<i>13</i>
1.7.7	<i>UART Full Duplex with RTS/CTS Flow Control.....</i>	<i>13</i>
1.8	RECOMMENDED EXTERNAL COMPONENTS .....	14
<b>2</b>	<b>FMT1000-Series Architecture.....</b>	<b>15</b>
2.1	FMT1000-SERIES CONFIGURATIONS .....	15
2.1.1	<i>FMT1010 IMU.....</i>	<i>15</i>
2.1.2	<i>FMT1020 VRU.....</i>	<i>15</i>
2.1.3	<i>FMT1030 AHRS.....</i>	<i>15</i>
2.2	SIGNAL PROCESSING PIPELINE .....	15
2.2.1	<i>Strap-down Integration.....</i>	<i>15</i>
2.2.2	<i>XKF3™ Sensor Fusion Algorithm.....</i>	<i>15</i>
2.2.3	<i>Frames of reference used in FMT1000-Series.....</i>	<i>16</i>
<b>3</b>	<b>3D Orientation and Performance Specifications .....</b>	<b>17</b>
3.1	3D ORIENTATION SPECIFICATIONS .....	17
3.2	SENSORS SPECIFICATIONS .....	17
<b>4</b>	<b>Sensor Calibration.....</b>	<b>19</b>
<b>5</b>	<b>System and Electrical Specifications .....</b>	<b>19</b>
5.1	INTERFACE SPECIFICATIONS .....	19
5.2	SYSTEM SPECIFICATIONS .....	19
5.3	ELECTRICAL SPECIFICATIONS.....	20
5.4	ABSOLUTE MAXIMUM RATINGS.....	20
5.5	COMPLIANCE.....	20
<b>6</b>	<b>FMT1000-Series Settings and Outputs.....</b>	<b>21</b>
6.1	MESSAGE STRUCTURE .....	21
6.2	OUTPUT SETTINGS .....	22
6.3	MTDATA2.....	23
6.4	SYNCHRONIZATION AND TIMING.....	24
<b>7</b>	<b>Magnetic Interference.....</b>	<b>25</b>
7.1	MAGNETIC FIELD MAPPING .....	25
7.2	ACTIVE HEADING STABILIZATION (AHS).....	25
<b>8</b>	<b>Package and Handling .....</b>	<b>26</b>
8.1	PACKAGE DRAWING .....	26
8.2	MOUNTING CONSIDERATIONS.....	27
8.3	PACKAGING.....	28
8.4	REFLOW SPECIFICATION.....	28

# 1 General Information

## 1.1 Ordering Information

Part Number	Output	Package	Packing Method
FMT1010T	IMU; inertial data	FMT28_028, JEDEC-PLCC-28 Compatible	Tray of 20
FMT1020T	VRU; inertial data, roll/pitch (referenced), yaw (unreferenced)	FMT28_028, JEDEC-PLCC-28 Compatible	Tray of 20
FMT1030T	AHRS; inertial data, roll/pitch/yaw	FMT28_028, JEDEC-PLCC-28 Compatible	Tray of 20
FMT1010R	IMU; inertial data	FMT28_028, JEDEC-PLCC-28 Compatible	Reel of 250
FMT1020R	VRU; inertial data, roll/pitch (referenced), yaw (unreferenced)	FMT28_028, JEDEC-PLCC-28 Compatible	Reel of 250
FMT1030R	AHRS; inertial data, roll/pitch/yaw	FMT28_028, JEDEC-PLCC-28 Compatible	Reel of 250

**Note:**

- Other packaging methods available on request. Contact Fairchild for more information.

## 1.2 Block Diagram

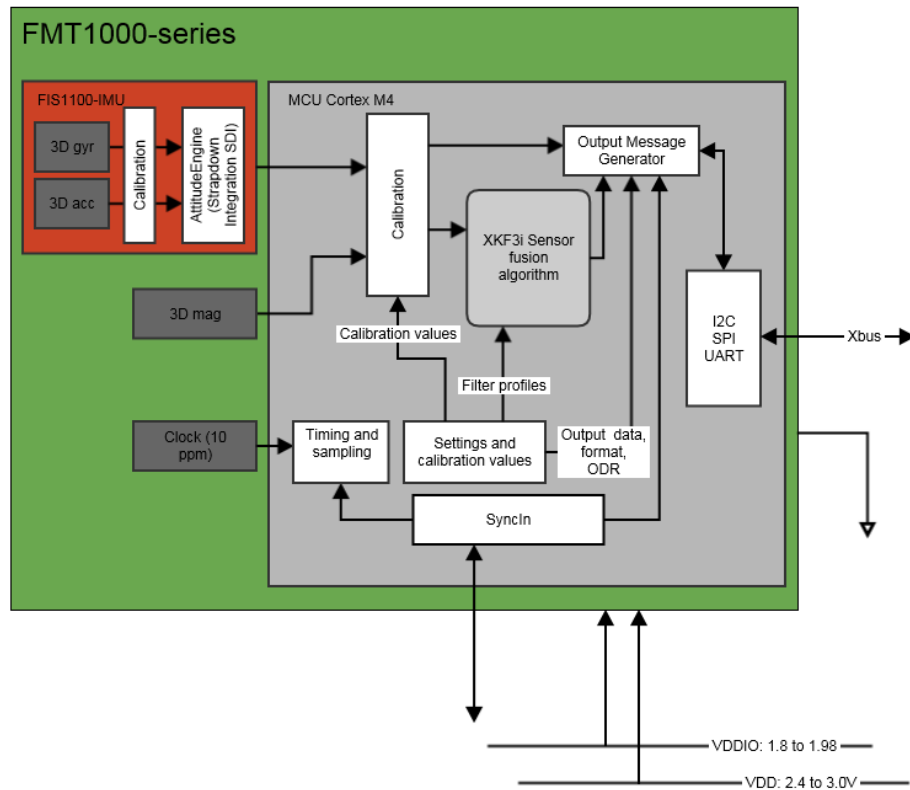

Figure 2. FMT1000-Series Module Block Diagram

### 1.3 Typical Application

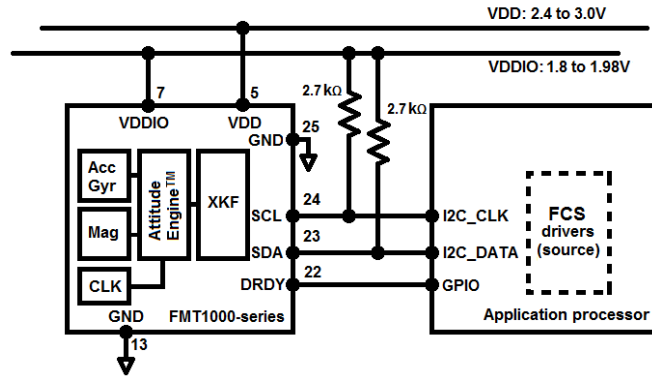

Figure 3. Typical Application

### 1.4 Pin Configuration

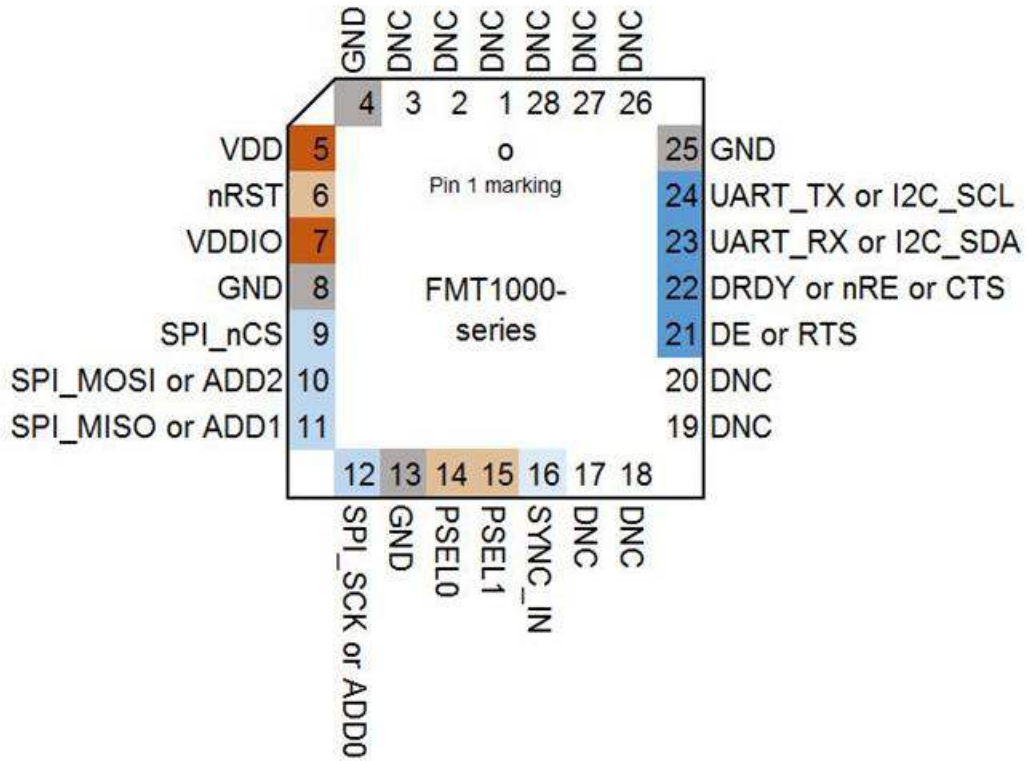

Figure 4. Pin Assignment

## 1.5 Pin Map

The pin map depends on the peripheral selection. See section 1.7 on how to set the peripherals.

Pin #	PSEL: I <sup>2</sup> C	PSEL: SPI	PSEL: UART Half Duplex	PSEL: UART Full Duplex
1	DNC	DNC	DNC	DNC
2	DNC	DNC	DNC	DNC
3	DNC	DNC	DNC	DNC
4	GND	GND	GND	GND
5	VDD	VDD	VDD	VDD
6	nRST	nRST	nRST	nRST
7	VDDIO	VDDIO	VDDIO	VDDIO
8	GND	GND	GND	GND
9	DNC	SPI_NCS	DNC	DNC
10	ADD2 <sup>(2)</sup>	SPI_MOSI	DNC	DNC
11	ADD1	SPI_MISO	DNC	DNC
12	ADD0	SPI_SCK	DNC	DNC
13	GND	GND	GND	GND
14	PSEL0	PSEL0	PSEL0	PSEL0
15	PSEL1	PSEL1	PSEL1	PSEL1
16	SYNC_IN	SYNC_IN	SYNC_IN	SYNC_IN
17	DNC	DNC	DNC	DNC
18	DNC	DNC	DNC	DNC
19	DNC	DNC	DNC	DNC
20	DNC	DNC	DNC	DNC
21	DNC	DNC	DE	RTS
22	DRDY	DRDY	nRE	CTS <sup>(3)</sup>
23	I2C_SDA	DNC	UART_RX	UART_RX
24	I2C_SCL	DNC	UART_TX	UART_TX
25	GND	GND	GND	GND
26	DNC	DNC	DNC	DNC
27	DNC	DNC	DNC	DNC
28	DNC	DNC	DNC	DNC

**Notes:**

2. I<sup>2</sup>C addresses, see Table 3: List of I2C Addresses
3. CTS cannot be left unconnected if the interface is set to UART full duplex. If HW flow control is not used, connect to GND.

## 1.6 Pin Descriptions

Name	Type	Description
<b>Power Interface</b>		
VDD	Power	Power supply voltage for sensing elements.
VDDIO	Power	Digital I/O supply voltage.
<b>Controls</b>		
PSEL0	Selection Pins	These pins determine the signal interface. See table below. Note that when the PSEL0/PSEL1 is not connected, its value is 1. When PSEL0/PSEL1 is connected to GND, its value is 0.
PSEL1		
nRST		Active low reset pin. Only drive with an open drain output or momentary (tactile) switch to GND. During normal operation this pin must be left floating, because this line is also used for internal resets. This pin has a weak pull-up to VDDIO.
ADD2	Selection Pins	I <sup>2</sup> C address selection lines.
ADD1		
ADD0		
<b>Signal Interface</b>		
I2C_SDA	I <sup>2</sup> C Interface	I <sup>2</sup> C serial data.
I2C_SCL		I <sup>2</sup> C serial clock.
SPI_nCS	SPI Interface	SPI chip select (active low).
SPI_MOSI		SPI serial data input (slave).
SPI_MISO		SPI serial data output (slave).
SPI_SCK		SPI serial clock.
RTS	UART Interface	Hardware flow control in UART full duplex mode (Ready-to-Send).
CTS		Hardware flow control in UART full duplex mode (Clear-to-Send).
nRE		Receiver control signal in UART half duplex mode.
DE		Transmitter control signal in UART half duplex mode.
UART_RX		Receiver data input.
UART_TX		Transmitter data output.
SYNC_IN	Sync Interface	SYNC_IN accepts a trigger which sends out the latest available data message
DRDY	Data Ready	Data ready pin indicates that data is available (SPI / I <sup>2</sup> C).

## 1.7 Peripheral Interface Selection

The FMT1000-series modules are designed to be used as a peripheral device in embedded systems. The module supports Universal Asynchronous Receiver/Transmitter (UART), inter-integrated circuit (I<sup>2</sup>C) and the Serial Peripheral Interface (SPI) protocols. The I<sup>2</sup>C and SPI protocols are well suited for communications between integrated circuits with on-board peripherals. The FMT1000-series modules have four modes of peripheral interfacing. Only one mode can be used at a time and is determined by the state of peripheral selection pins PSEL0 and PSEL1 at startup. Table 1 specifies how the PSEL lines select the peripheral interface. Note that the module has internal pull-ups. Not connecting PSEL results in a value of 1, connecting PSEL to a GND results in a value of 0. Examples for communication on embedded systems are available at <https://developer.mbed.org/teams/Fairchild-Semiconductor>

**Table 1. Peripheral Interface Selection**

Interface	PSEL0	PSEL1
I <sup>2</sup> C	1	1
SPI	0	1
UART Half-Duplex	1	0
UART Full-Duplex	0	0

### 1.7.1 Peripheral Interface Architecture

At its core the module uses the proprietary Xbus protocol. This protocol is available on all interfaces, UART (asynchronous serial port interfaces) and I<sup>2</sup>C and SPI buses. The I<sup>2</sup>C and SPI buses differ from UART in that they are synchronous and have a master-slave relation in which the slave cannot send data by itself. This makes the Xbus protocol not directly transferable to these buses. For this the MTSSP protocol is introduced that provides a way to exchange standard Xbus protocol messages over the I<sup>2</sup>C and SPI buses.

Figure 5 shows how MTSSP is fitted in the module's (simplified) communication architecture. The module has generic Input- and Output-Queues for Xbus protocol messages. For I<sup>2</sup>C and SPI these messages are translated by the MTSSP layer. For the UART connection these messages are transported as-is.

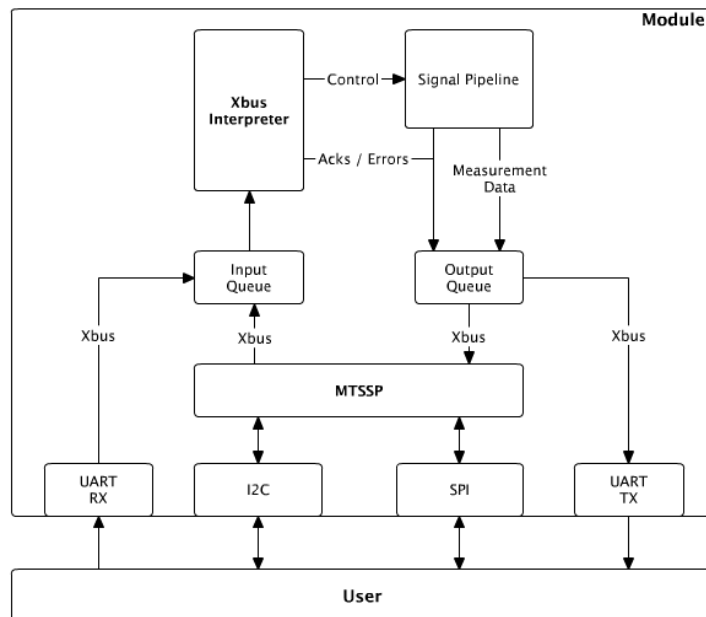

**Figure 5. FMT Module Architecture**

### 1.7.2 Xbus Protocol

The Xbus protocol is a proprietary protocol that allows straightforward interfacing with the FMT1000-series. Information about the Xbus protocol can be found in the Low-Level Communication Protocol Documentation. Section 6 provides a short introduction on the Xbus protocol. It is advised to go read this short introduction first before proceeding to the MTSSP explanation.

### 1.7.3 MTSSP Synchronous Serial Protocol

The communication protocol used for both I<sup>2</sup>C and SPI is called MTSSP (MT Synchronous Serial Protocol).

#### Data Flow

MTSSP communication happens according the master-slave model. The FMT1000-series module will always fulfill the slave-role while the user/integrator of the module is always the Master.

Communication is always initiated and driven by the Master; the Master either writes data to the module or the Master reads data from the module. The Master sends messages to the module in order to control it. These messages are reduced Xbus messages. A reduced Xbus message is equal to a normal Xbus message with the exception that preamble and BusID are removed to save bandwidth. The calculation of the checksum is done by assuming a BusID value of 0xFF (master device).

The module needs time to process the control messages it receives and will generate an acknowledge message when ready. In order to get these acknowledge messages at the Master the Master needs to read them.

The following diagram shows data flow between Master and module:

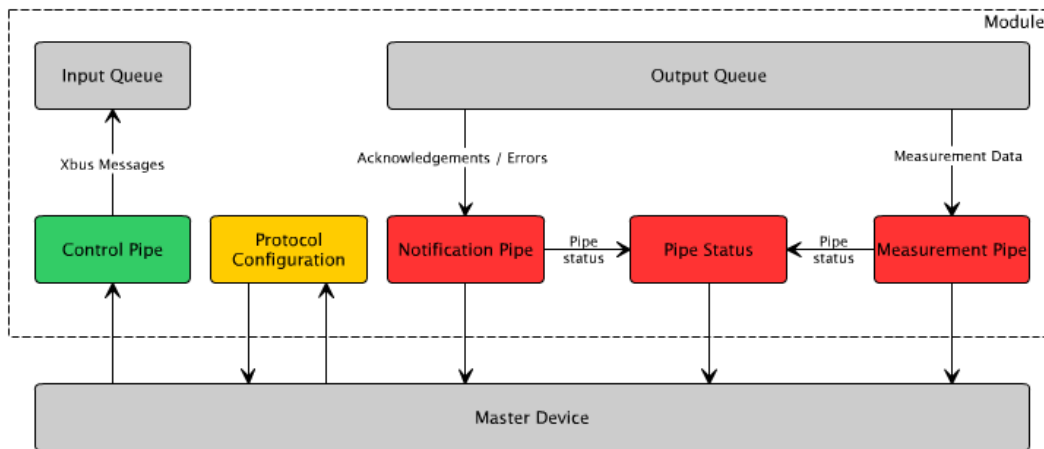

**Figure 6. Data Flows within MTSSP**

#### Data Ready Signal

The Data Ready Signal (DRDY) is a notification line driven by the module. Its default behavior is to indicate the availability of new data in either the notification- or the measurement pipe. By default, the line is idle low and will go high when either pipe contains an item. When both pipes are empty the DRDY line will go low

again. The Master can change the behavior of the DRDY signal.

The polarity can be changed to idle high, the output type can be switched between push-pull and open drain. The state of a specific pipe can be ignored. For example, it can be configured that the presence of data in the notification pipe won't influence the state of the DRDY pin.

#### Opcodes

The following opcodes are defined.

**Table 2. Opcodes for SPI and I<sup>2</sup>C**

Opcode	Name	Read/Write	Description
0x01	ProtocolInfo	Read	Status of the protocol behaviour, protocol version
0x02	ConfigureProtocol	Write	Tweak the Protocol, e.g. the behaviour of the DRDY pin, behaviour of the pipes
0x03	ControlPipe	Write	Used to send control messages to the module
0x04	PipeStatus	Read	Provides status information for the read pipes
0x05	NotificationPipe	Read	Used to read non-measurement data: errors acknowledgements and other notifications from the module
0x06	MeasurementPipe	Read	All measurement data generated by the module will be available in the measurement pipe



**ProtocolInfo (0x01)**

The ProtocolInfo opcode allows the Master to read the active protocol configuration. The format of the message is as follows (All data is little endian, byte aligned):

```
struct MtsspInfo
{
    uint8_t m_version;
    uint8_t m_drdyConfig;
};
    m_version
```

7	6	5	4	3	2	1	0
VERSION [7:0]							

m\_drdyConfig

Bits 7:4	Reserved for future use
Bit 3	MEVENT: Measurement pipe DRDY event enable 0: Generation of DRDY event is disabled 1: Generation of DRDY event is enabled
Bit 2	NEVENT: Notification pipe DRDY event enable 0: Generation of DRDY event is disabled 1: Generation of DRDY event is enabled
Bit 1	OTYPE: Output type of DRDY pin 0: Push/pull 1: Open drain
Bit 0	POL: Polarity of DRDY signal 0: Idle low 1: Idle high

**ConfigureProtocol (0x02)**

The ProtocolInfo opcode allows the Master to change the active protocol configuration. The format of the message is as follows (All data is little endian, byte aligned):

```
struct MtsspConfiguration
{
    uint8_t m_drdyConfig;
};
    m_drdyConfig
```

Bits 7:4	Reserved for future use
Bit 3	MEVENT: Measurement pipe DRDY event enable 0: Generation of DRDY event is disabled 1: Generation of DRDY event is enabled
Bit 2	NEVENT: Notification pipe DRDY event enable 0: Generation of DRDY event is disabled 1: Generation of DRDY event is enabled
Bit 1	OTYPE: Output type of DRDY pin 0: Push/pull 1: Open drain
Bit 0	POL: Polarity of DRDY signal 0: Idle high 1: Idle low

**ControlPipe (0x03)**

The ControlPipe opcode allows the Master to write messages to the control pipe. The bytes following the opcode are interpreted as a single (reduced) Xbus message

**PipeStatus (0x04)**

The PipeStatus opcode allows the Master to retrieve the status of the module's Notification- and Measurement pipes. The format of the message is as follows (All data is little endian, byte aligned):

```
struct MtsspConfiguration
{
    uint16_t m_notificationMessageSize;
    uint16_t m_measurementMessageSize;
};
```

**NotificationPipe (0x05)**

The NotificationPipe opcode is used to read from the notification pipe. The read data is a single reduced Xbus message

**MeasurementPipe (0x06)**

The MeasurementPipe opcode is used to read from the measurement pipe. The read data is a single reduced Xbus message

### 1.7.4 I<sup>2</sup>C

The FMT1000-series supports the I<sup>2</sup>C transport layer. The FMT1000-series module acts as an I<sup>2</sup>C Slave. The Master is defined as the user of the FMT1000-series module.

The I<sup>2</sup>C slave address is determined by the ADD0, ADD1 and ADD2 pins. These pins are pulled-up internally so when left unconnected the address selection defaults to ADD[0..2] = 111.

**Table 3. List of I<sup>2</sup>C Addresses**

I <sup>2</sup> C Address	ADD0	ADD1	ADD2
0x1D	0	0	0
0x1E	1	0	0
0x28	0	1	0
0x29	1	1	0
0x68	0	0	1
0x69	1	0	1
0x6A	0	1	1
0x6B (default)	1	1	1

**Table 4. Implemented I<sup>2</sup>C Bus Protocol Features**

Feature	Slave Requirement	FMT1000-Series
7-Bit Slave Address	Mandatory	Yes
10-Bit Slave Address	Optional	No
Acknowledge	Mandatory	Yes
Arbitration	N/A	N/A
Clock Stretching	Optional	Yes <sup>(4)</sup>
Device ID	Optional	No
General Call Address	Optional	No
Software Reset	Optional	No
START byte	N/A	N/A
START Condition	Mandatory	Yes
STOP Condition	Mandatory	Yes
Synchronization	N/A	N/A

**Note:**

- The FMT1000-series module relies on the I<sup>2</sup>C clock stretching feature to overcome fluctuations in processing time, the Master is required to support this feature

**Reading from the module**

Reading from the module should start by first writing an opcode that tells the module what the Master needs to read. Based on the opcode the module will prepare the related data to be transmitted. The Master then can do an I<sup>2</sup>C read transfer to retrieve the data. Starting the read transfer after the opcode write can also be done using a repeated start condition as is shown in Figure 7.

It is up to the Master to determine how many bytes need to be read. The Master should use the PipeStatus (0x04) opcode of the MTSSP protocol for this.

If the master reads more bytes than necessary the FMT1000-series will restart sending the requested data from the beginning.

The following diagram shows a read message transfer using a repeated start:

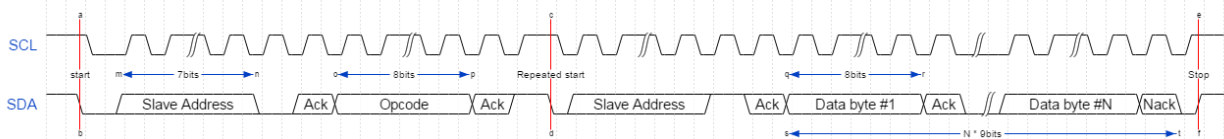

**Figure 7. Read Message Transfer using a Repeated Start (I<sup>2</sup>C)**

The following diagram shows a read message transfer using a full write transfer for the opcode followed by a read transfer to get the data:

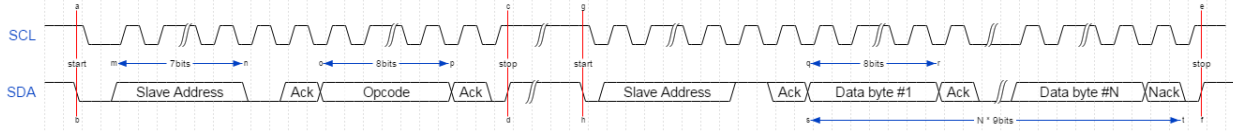

**Figure 8. Full Write Transfer and Full Read Transfer (I<sup>2</sup>C)**

### 1.7.5 SPI

The FMT1000-series supports the SPI transport layer. The FMT1000-series module acts as an SPI Slave. The Master is defined as the user of the FMT1000-series module.

The module uses SPI mode 3; Data is captured on the rising clock edge and data is latched/propagated on the falling clock edge. (CPOL=1 and CPHA=1);

Data is clocked-out MSB first. The module uses an 8-bit data format

#### SPI Configuration

The FMT1000-series supports 4-wire mode SPI. The four lines used are:

#### Data Transfer

There is a single type of SPI transfer used for all communications. The diagram below shows the basic transfer.

- Chipselect (SPI\_nCS)
- Serial Clock (SPI\_SCK)
- Master data in, slave data out (SPI\_MISO)
- Master data out, slave data in (SPI\_MOSI)

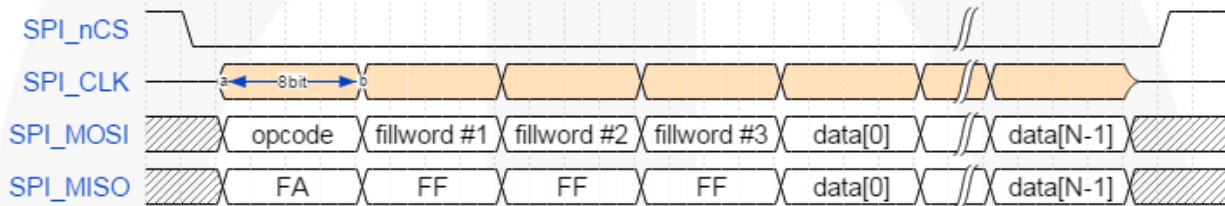

**Figure 9. SPI Basic Transfer**

A transfer is started selecting the Slave by pulling the SPI\_nCS low. The SPI\_nCS line is to be kept low for the duration of the transfer. The Slave will interpret the rising edge of the SPI\_nCS line as the end of the transfer.

The second- to fourth byte transmitted are the fill words. These fill words are needed to give the Slave some time to prepare the remainder of the transfer. In principal, the Slave is free to choose the value of the fill word; and its value should therefore be ignored by the Master. However, the first 4 bytes transmitted by the FMT1000-series module are always 0xFA, 0xFF, 0xFF, 0xFF.

The Master places the data it needs to transmit on the SPI\_MOSI line. The Slave will place its data on the SPI\_MISO line.

Following the first four words are the actual data of the transfer. It is the responsibility of the Master to determine how many bytes need to be transferred. The Master should use the PipeStatus (0x04) opcode of the MTSSP protocol for this.

The first byte transmitted by the Master is the opcode which identifies what kind of data is transmitted by the Master and what kind of data the Master wants to read from the Slave (See MTSSP).

#### Timing

The following timing constraints apply to the SPI transport layer.

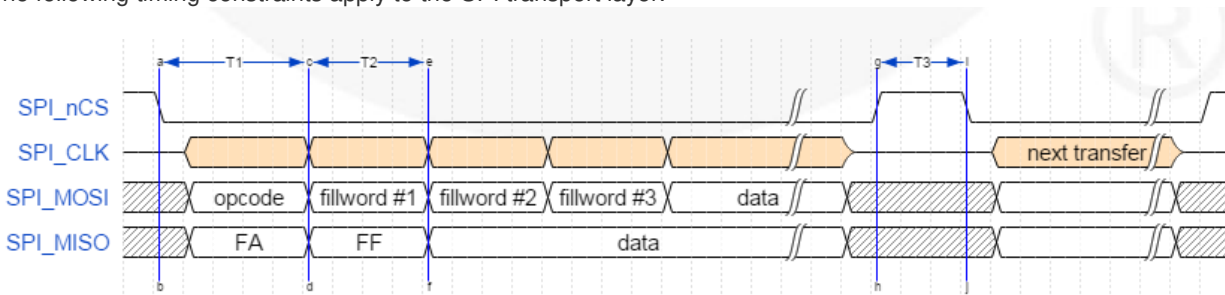

**Figure 10. SPI Timing**

**Table 5. Timing Specifications**

Symbol	Parameter	Min.	Max.	Unit
T1	Slave select to first complete word delay	4		μs
T2	Byte time	4		μs
T3	Consecutive SPI transfer guard time	3		μs
	Max. SPI bitrate		2	Mbit

**1.7.6 UART Half Duplex**

The FMT1000-series module can be configured to communicate over UART in half duplex mode. The UART frame configuration is 8 data bits, no parity and 1 stop bit (8N1). In addition to the RX and TX pins, the control lines nRE and DE are used. These control outputs are used to drive the TX signal on a shared medium and to drive the signal of the shared medium on the RX signal.

A typical use case for this mode is to directly drive a RS485 transceiver where the shared medium is the RS485 signal and nRE and DE lines control the buffers inside the transceiver.

When the FMT is transmitting data on its TX pin it will raise both the nRE and DE lines, else it will pull these lines low.



**Figure 11. Behavior of the nRE and DE Lines**

Note that in this mode the UART of the FMT1000-series itself is still operating full duplex.

**1.7.7 UART Full Duplex with RTS/CTS Flow Control**

The FMT1000-series module can be configured to communicate over UART in full duplex mode with RTS/CTS flow control. The UART frame configuration is 8 data bits, no parity and 1 stop bit (8N1). In addition to the RX and TX signals for data communication the RTS and CTS signals are used for hardware flow control.

The CTS signal is an input for the FMT. The FMT checks the state of the CTS line at the start of every byte it transmits. If CTS is low the byte will be transmitted. Otherwise transmission is postponed until CTS is lowered. When during the transmission of a byte the CTS signal is raised, then the transmission of that byte is completed before postponing further output. This byte will not be retransmitted. This behavior is shown in the following image:

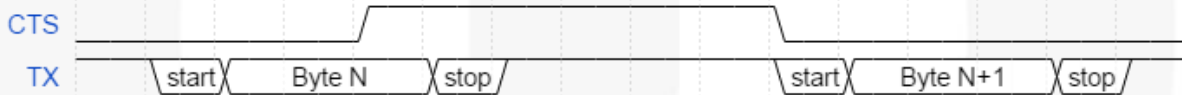

**Figure 12. Data Transmit Behavior Under CTS**

The RTS signal is an output for the FMT. If the RTS line is high, the FMT is busy and unable to receive new data. Otherwise the FMT's UART is idle and ready to receive. After receiving a byte the DMA controller of the

FMT will transfer the byte to its receive FIFO. The RTS signal will be asserted during this transfer. So with every byte received the RTS line is raised shortly like shown in the following image:

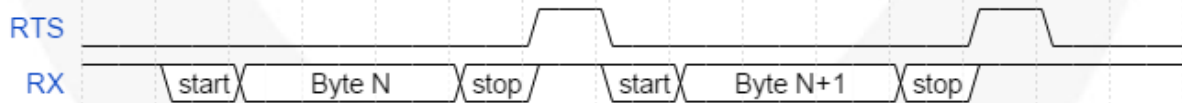

**Figure 13. FRTS Behavior Under Data Reception**

This communication mode can be used without hardware flow control. In this case the CTS line needs to be tied low (GND) to make the FMT transmit.

## 1.8 Recommended External Components

Description	Component	Typical value
I <sup>2</sup> C Pull-up Resistor	R <sub>pu</sub>	2.7 kΩ

**Notes:**

5. R<sub>pu</sub> is only needed when the FMT1000-series is configured for I<sup>2</sup>C interface.
6. R<sub>PSEL</sub> is only required when interface is not I<sup>2</sup>C.

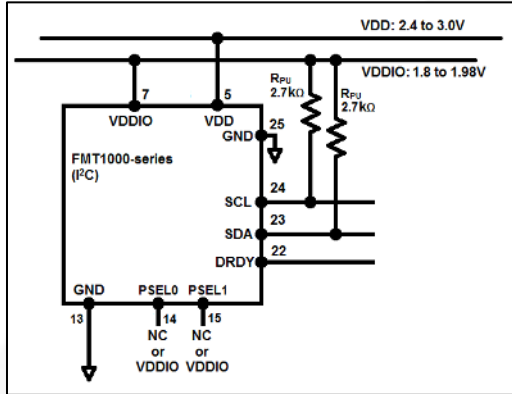

Figure 14. External Components (I<sup>2</sup>C Interface)

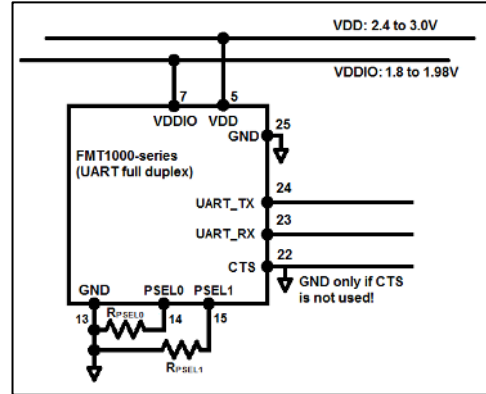

Figure 15. External Components (UART Interface)

## 2 FMT1000-Series Architecture

This section discusses the FMT1000-series architecture including the various configurations and the signal processing pipeline.

### 2.1 FMT1000-Series Configurations

The FMT1000-series is fully-tested, self-contained modules that can 3D output orientation data (Euler angles (roll, pitch, and yaw), rotation matrix (DCM) and quaternions), orientation and velocity increments ( $\Delta q$  and  $\Delta v$ ) and sensors data (acceleration, rate of turn, magnetic field). The FMT1000-series module is available as an Inertial Measurement Unit (IMU), Vertical Reference Unit (VRU) and Attitude and Heading Reference System (AHRS). Depending on the product, output options may be limited to sensors data and/or unreferenced yaw.

All FMT1000-series feature the Fairchild FIS1100 (an accelerometer/gyroscope combo-sensor), a magnetometer, a high-accuracy crystal and a low-power MCU. The MCU coordinates the synchronization and timing of the various sensors, it applies calibration models (e.g. temperature modules) and output settings and runs the sensor fusion algorithm. The MCU also generates output messages according to the proprietary XBus communication protocol. The messages and the data output are fully configurable, so that the FMT1000-series limits the load, and thus power consumption, on the application processor.

#### 2.1.1 FMT1010 IMU

The FMT1010 module is an Inertial Measurement Unit (IMU) that outputs 3D rate of turn, 3D acceleration and 3D magnetic field. The FMT1000-series also outputs coning and sculling compensated orientation increments and velocity increments ( $\Delta q$  and  $\Delta v$ ) from its AttitudeEngine™. Advantages over a gyroscope-accelerometer combo-sensor are the inclusion of synchronized magnetic field data, on-board signal processing and the easy-to-use communication protocol. Moreover, the testing and calibration performed by Fairchild result in a robust and reliable sensor module, that can be integrated within a short time frame. The signal processing pipeline and the suite of output options allow access to the highest possible accuracy at any bandwidth, limiting the load on the application processor.

#### 2.1.2 FMT1020 VRU

The FMT1020 is a 3D vertical reference unit (VRU). Its orientation algorithm (XKF3™) outputs 3D orientation data with respect to a gravity referenced frame: drift-free roll, pitch and unreferenced yaw. In addition, it outputs calibrated sensor data: 3D acceleration, 3D rate of turn and 3D earth-magnetic field data. All modules of the FMT1000-series are also capable of outputting data generated by the strap down integration algorithm (the AttitudeEngine outputting orientation and velocity increments  $\Delta q$  and  $\Delta v$ ). The 3D acceleration is also available as so-called free acceleration which has gravity subtracted. Although the yaw is unreferenced, though still superior to gyroscope integration. With the feature Active Heading Stabilization (AHS, see section

7.2) the drift in unreferenced yaw can be limited to 1 deg after 60 minutes, even in magnetically disturbed environments.

#### 2.1.3 FMT1030 AHRS

The FMT1030 supports all features of the FMT1010 and FMT1020, and in addition is a full gyro-enhanced Attitude and Heading Reference System (AHRS). It outputs drift-free roll, pitch and true/magnetic North referenced yaw and sensors data: 3D acceleration, 3D rate of turn, as well as 3D orientation and velocity increments ( $\Delta q$  and  $\Delta v$ ), and 3D earth-magnetic field data. Free acceleration is also available for the FMT1030 AHRS.

### 2.2 Signal Processing Pipeline

The FMT1000-series is a self-contained module, so all calculations and processes such as sampling, coning and sculling compensation and the XKF3 sensor fusion algorithm run on board.

#### 2.2.1 Strap-down Integration

The optimized strap-down algorithm (AttitudeEngine) performs high-speed dead-reckoning calculations at 1 kHz allowing accurate capture of high frequency motions. This approach ensures a high bandwidth. Orientation and velocity increments are calculated with full coning and sculling compensation. At an output data rate of up to 100 Hz, no information is lost, yet the output data rate can be configured low enough for systems with limited communication bandwidth. These orientation and velocity increments are suitable for any 3D motion tracking algorithm. Increments are internally time-synchronized with the magnetometer data.

#### 2.2.2 XKF3™ Sensor Fusion Algorithm

XKF3 is a sensor fusion algorithm, based on Extended Kalman Filter framework that uses 3D inertial sensor data (orientation and velocity increments) and 3D magnetometer, also known as '9D' to optimally estimate 3D orientation with respect to an Earth fixed frame.

XKF3 takes the orientation and velocity increments together with the magnetic field updates and fuses this to produce a stable orientation (roll, pitch and yaw) with respect to the earth fixed frame.

The XKF3 sensor fusion algorithm can be processed with filter profiles. These filter profiles contain predefined filter parameter settings suitable for different user application scenarios.

The following filter profiles are available:

- **General** – suitable for most applications. Supported by the FMT1030 module.
- **Dynamic** – assumes that the motion is highly dynamic. Supported by the FMT1030 module.
- **High\_mag\_dep** – heading corrections rely on the magnetic field measured. To be used when magnetic field is homogeneous. Supported by the FMT1030 module.

- **Low\_mag\_dep** – heading corrections are less dependent on the magnetic field measured. Heading is still based on magnetic field, but more distortions are expected with less trust being placed on magnetic measurements. Supported by the FMT1030 module.
- **VRU\_general** – Roll and pitch are referenced to the vertical (gravity), yaw is determined by stabilized dead-reckoning, referred to as Active Heading Stabilization (AHS) which significantly reduces heading drift, see also section 7.2. Consider using VRU\_general in environments that have a heavily disturbed magnetic field. The VRU\_general filter profile is the only filter profile available for the FMT1020 VRU, also supported by the FMT1030 module

**2.2.3 Frames of reference used in FMT1000-Series**

The FMT1000-series module uses a right-handed coordinate system as the basis of the sensor of frame.

The following data is outputted in corresponding reference coordinate systems:

**Table 6. Frames of Reference used for FMT1000-Series Output**

Data	Symbol	Reference Coordinate System
Acceleration	$a_x, a_y, a_z$	Sensor-fixed
Rate of Turn	$\omega_x, \omega_y, \omega_z$	Sensor-fixed
Magnetic Field	$m_x, m_y, m_z$	Sensor-fixed
Free Acceleration	$a_x, a_y, a_z$	Local Tangent Plane (LTP), default ENU
Velocity Increment	$\Delta v_x, \Delta v_y, \Delta v_z$	Local Tangent Plane (LTP), default ENU
Orientation Increment	$\Delta q_0, \Delta q_1, \Delta q_2, \Delta q_3$	Local Tangent Plane (LTP), default ENU
Orientation	Euler angles, quaternions or rotation matrix	Local Tangent Plane (LTP), default ENU

Local Tangent Plane (LTP) is a local linearization of the Ellipsoidal Coordinates (Latitude, Longitude, Altitude) in the WGS-84 Ellipsoid.

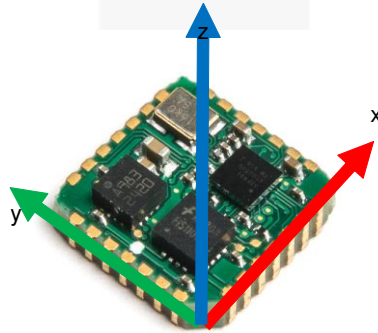

**Figure 16. Default Sensor fixed Coordinate System for the FMT1000-Series Module**

It is straightforward to apply a rotation matrix to the FMT, so that the velocity and orientation increments, free acceleration and the orientation output is output using that coordinate frame. The default reference coordinate system is East-North-Up (ENU) and the FMT1000-series has predefined output options for North-East-Down (NED) and North-West-Up (NWU). Any arbitrary alignment can be entered. These orientation resets have effect on all outputs that are by default outputted with an ENU reference coordinate system.



### 3 3D Orientation and Performance Specifications

#### 3.1 3D Orientation Specifications

**Table 7. Orientation Specifications**

Group	Parameter	Typ.	Unit	Comments
Roll/pitch	Static	±2.0	deg	Allow filter initialization of at least 60 sec
	Dynamic	±3.0	deg	Allow filter initialization of at least 60 sec
Yaw (heading)	Static/dynamic, Magnetic field referenced	±3.0	deg	FMT1030 AHRS only in a homogenous magnetic field and a filter profile using magnetic field as reference.
	VRU_general filter profile (unreferenced yaw)	5-10	deg after 60 min	Active Heading Stabilization (AHS) feature. See section 7.2 for more information.
	Output data rate orientation	0-100	Hz	Accuracy and latency independent of output data rate. Output data rate may be any integer divider of 100 Hz or may be triggered by an external pulse (SYNC_IN)

#### 3.2 Sensors Specifications

**Table 8. Gyroscope Specifications**

Parameter	Min.	Typ.	Unit	Comments
Full Range	±2000		deg/s	
Non-Linearity		<0.2	% of FS	
Sensitivity Variation		±0.05	%	Over-Temperature Range
Noise Density		0.01	°/s/√Hz	
In-Run bias Stability		10	deg/h	
Zero-Rate Output		±1	deg/s	Bias variation after calibration, bias is continuously estimated by XKF3i. The estimated biases are cleared on a device reset (including power cycle). Not applicable for FMT-1010 modules.
Bias Repeatability (1 yr)		0.5	deg/s	The bias is continuously estimated by XKF3. The estimated biases are cleared on a device reset (including power cycle). Not applicable for FMT1010 modules.
Bandwidth		200	Hz	
Natural Frequency		26	kHz	This is the resonating frequency of the mass in the gyro. The higher the frequency, the higher the accuracy.
Output date rate		1000	Hz	RateOfTurnHR DataID only; Acceleration DataID and velocity increments up to 100 Hz

**Table 9. Accelerometers Specifications**

Parameter	Min.	Typ.	Unit	Comments
Full Range	±8		g	
Non-Linearity		±1	% of FS	
Sensitivity Variation		0.05	%	Over-Temperature Range
Noise Density		50	µg/√Hz	
Zero-g Output		±50	mg	
In-Run bias Stability		0.1	mg	
Bandwidth		200	Hz	
Output date rate		1000	Hz	AccelerationHR DataID only; Rate of Turn DataID and orientation increments up to 100 Hz

**Table 10. Magnetometer Specifications**

Parameter	Min.	Typ.	Max.	Unit.	Comments
Full Range	±1.9			Gauss	
Non-Linearity		0.1		% of FS	
Noise Density		200		µG/√Hz	

**Table 11. Alignment Specifications**

Parameter	Typ.	Unit	Comments
Non-Orthogonality (Accelerometer)	0.1	deg	
Non-Orthogonality (Gyroscope)	0.1	deg	
Non-Orthogonality (Magnetometer)	0.1	deg	
Alignment (gyr to acc)	0.1	deg	
Alignment (mag to acc)	0.2	deg	
Alignment of acc to the module board	0.3	deg	

## 4 Sensor Calibration

Each FMT is individually calibrated and tested over its temperature range. The (simplified) sensor model of the gyroscopes, accelerometers and magnetometers can be represented as following:

$$s = K_T^{-1}(u - b_T)$$

s = sensor data of the gyroscopes, accelerometers and magnetometers in rad/s, m/s<sup>2</sup> or a.u. respectively

K<sub>T</sub><sup>-1</sup> = gain and misalignment matrix (temperature compensated)

u = sensor value before calibration (unsigned 16-bit integers from the sensor)

b<sub>T</sub> = bias (temperature compensated)

Fairchild's calibration procedure calibrates for many parameters, including bias (offset), alignment of the sensors with respect to the module PCB and each other and gain (scale factor). All calibration values are temperature dependent and temperature calibrated. The calibration values are stored in non-volatile memory in the FMT1000-series.

## 5 System and Electrical Specifications

### 5.1 Interface Specifications

**Table 12. Communication Interfaces**

Interface	Description	Min.	Typ.	Max.	Units
I <sup>2</sup> C	Host I <sup>2</sup> C interface speed			400	kHz
SPI	Host SPI Interface Speed			2	MHz
	Clock Duty Cycle	30	50	70	%
UART	Baud Rates		921.6	4000	kbps

**Table 13. Auxiliary Interfaces**

Interface	Description	Min.	Max.	Unit	Comments
SYNC_IN	V <sub>IL</sub>		0.3 * VDDIO	V	Digital Input Voltage
	V <sub>IH</sub>	0.45 * VDDIO + 0.3		V	Digital Input Voltage
	V <sub>HYS</sub>	0.45 * VDDIO + 0.3		V	
nRST	V <sub>IL</sub>		0.3 * VDDIO	V	Only drive momentarily
	R <sub>PU</sub>	30	50	kΩ	Pull-up Resistor
	Generated reset pulse duration	20		μs	

### 5.2 System Specifications

**Table 14. System Specifications**

Interface	Description	Min.	Typ.	Max.	Unit	Comments
Size	Width/Length	12.0	12.1	12.2	mm	PLCC-28 Compatible
	Height	2.45	2.55	2.65	mm	
Weight			0.66		gram	
Temperature	Operating Temperature	-40		+85	°C	Ambient Temperature, Non-Condensing
	Specified performance Operating Temperature	0		+60	°C	
Power Consumption			44		mW	V <sub>DD</sub> 3.0 V; V <sub>DDIO</sub> 1.8 V
Timing Accuracy			10		ppm	

### 5.3 Electrical Specifications

**Table 15. Electrical Specifications**

Parameter	Min.	Typ.	Max.	Unit	Comments
VDD	2.4	2.7	3.0	V	VDD should be applied first or at the same time as VDDIO
VDDIO	1.80		1.98	V	
V <sub>IL</sub>			0.3 * VDDIO	V	Digital Input Voltage
V <sub>IH</sub>	0.45 * VDDIO + 0.3			V	Digital Input Voltage
V <sub>HYS</sub>	0.45 * VDDIO + 0.3			V	Digital Input Voltage
V <sub>OL</sub>			0.4	V	Digital Output Voltage
V <sub>OH</sub>	VDDIO - 0.4			V	Digital Output Voltage

### 5.4 Absolute Maximum Ratings

Stresses exceeding the absolute maximum ratings may damage the device. The device may not function or be operable above the recommended operating conditions and stressing the parts to these levels is not recommended. In addition, extended exposure to stresses above the recommended operating conditions may affect device reliability. The absolute maximum ratings are stress ratings only.

Symbol	Parameter		Min.	Max.	Unit	Comments
TSTD	Storage Temperature		-40	+125	°C	
T <sub>A</sub>	Operating Temperature		-40	+85	°C	
	VDD		0.3	3.60	V	
	VDDIO		0.3	2.05	V	
	Acceleration <sup>(7)</sup>			10,000	g	Any axis, unpowered, for 0.2 ms
ESD	Electrostatic Discharge Capability	Human Body Model, ANSI/ESDA/JEDEC JS-001-2012 <sup>(8)</sup>		±2000	V	

**Notes:**

- 7.  $\Delta$  This is a mechanical shock (g) sensitive device. Proper handling is required to prevent damage to the part.
- 8.  $\swarrow$  This is an ESD-sensitive device. Proper handling is required to prevent damage to the part.

### 5.5 Compliance

The FMT1000-series modules and FEBFMT1030 Evaluation Board are RoHS compliant. The FMT1000-series modules are CE/FCC certified.

## 6 FMT1000-Series Settings and Outputs

The FMT1000-series module uses the proprietary Xbus protocol.

### 6.1 Message Structure

The communication with the MT is done by messages which are built according to a standard structure. The message has two basic structures; one with a standard length and one with extended length. The standard length message has a maximum of 254 data bytes and is used most frequently. In some cases the extended length message needs to be used if the number of data bytes exceeds 254 bytes.

An MT message (standard length) contains the following fields:

Xbus header				DATA	CHECKSUM
Preamble	BID	MID	LEN		

An MT message (extended length) contains these fields:

Preamble	BID	MID	LEN <sup>ext</sup>	LEN	DATA	CHECKSUM
----------	-----	-----	--------------------	-----	------	----------

**Table 16. Message Structure**

Field	Field Width	Description
Preamble	1 byte	Indicator of start of packet → 250 (0xFA)
BID	1 byte	Bus identifier or Address → 255 (0xFF)
MID	1 byte	Message identifier
LEN	1 byte	For standard length message: – Value equals number of bytes in DATA field. – Maximum value is 254 (0xFE) For extended length message: – Field value is always 255 (0xFF)
EXT LEN	2 bytes	16 bit value representing the number of data bytes for extended length messages. Maximum value is 2048 (0x0800)
IND ID	1 byte	The type of indication received
DATA (standard length)	0 – 254 bytes	Data bytes (optional)
DATA (extended length)	255 – 2048 bytes	Data bytes
Checksum	1 byte	Checksum of message

Details on the Xbus protocol message structure can be found in the Fairchild MT Low Level Communication Protocol documentation.

## 6.2 Output Settings

The section below only describes the most important set of MTData2 data messages. For all messages supported by the FMT1000-series, refer to the Fairchild MT Low Level Communication Protocol documentation (LLCP).

The Output Configuration message sets the output of the device. Each data message has a DataID which consists of a data type and a number format. Table 18 shows the most important MTData2 Data identifiers. The message SetOutputconfiguration holds the DataID and the output frequency.

### SetOutputConfiguration

MID 192 (0xC0)

DATA OutputConfig (N\*4 bytes)

Set the output configuration of the device.

The data is a list of maximum 32 data identifiers combined with a desired output frequency. The response message contains a list with the same format, but with the values actually used by the device.

Each entry in the list contains:

**Table 17. Output Configuration Parameters**

Offset	Value
0	Data Identifier (2 bytes)
2	Output frequency (2 bytes)

**Table 18. DataID's**

Group Name	Type Name	XDA Type Name <sup>(9)</sup>	Hex Value <sup>(10)</sup>
Timestamp		XDI_TimestampGroup	
	Packet Counter	XDI_PacketCounter	1020
	Sample Time Fine	XDI_SampleTimeFine	1060
Orientation Data		XDI_OrientationGroup	
	Quaternion	XDI_Quaternion	201y
	Rotation Matrix	XDI_RotationMatrix	202y
	Euler Angles	XDI_EulerAngles	203y
Acceleration		XDI_AccelerationGroup	
	Delta V (dv)	XDI_DeltaV	401y
	Acceleration	XDI_Acceleration	402y
	Free Acceleration	XDI_FreeAcceleration	403y
	AccelerationHR	XDI_AccelerationHR	404y
Angular Velocity		XDI_AngularVelocityGroup	
	Rate of Turn	XDI_RateOfTurn	802y
	Delta Q (dq)	XDI_DeltaQ	803y
	RateOfTurnHR	XDI_RateOfTurnHR	804y
Magnetic		XDI_MagneticGroup	
	Magnetic Field	XDI_MagneticField	C02y
Status		XDI_StatusGroup	
	Status Word	XDI_StatusWord	E020

### Notes:

9. XDA: Communication protocol in C, to be used on external processors

10. y: The hex value of the Format bits (see Table 19 below). The value is formed by doing a bitwise OR of the available fields.

**Table 19. Format Bits**

Field	Format	Description	Short Name
Precision			
	0x0	Single precision IEEE 32-bit floating point number	Float32
	0x1	Fixed point 12.20 32-bit number	Fp1220
	0x2	Fixed point 16.32 48-bit number	Fp1632
	0x3	Double precision IEEE 64-bit floating point number	Float64
Coordinate System			
	0x0	East-North-Up coordinate system	ENU
	0x4	North-East-Down coordinate system	NED
	0x8	North-West-Up	NWU

Example: The DataID for quaternions in NED coordinate system with fixed point 16.32 number format is represented as 0x2016.

### 6.3 MTData2

Data is represented in the MTData2 message.

#### MTData2

MID 54 (0x36)

DATA DATA (length variable)

The MTData2 message contains output data according the current OutputConfiguration. An MTData2 message consists of one or more packets, each containing a specific output. The layout of an MTData2 message is shown below:

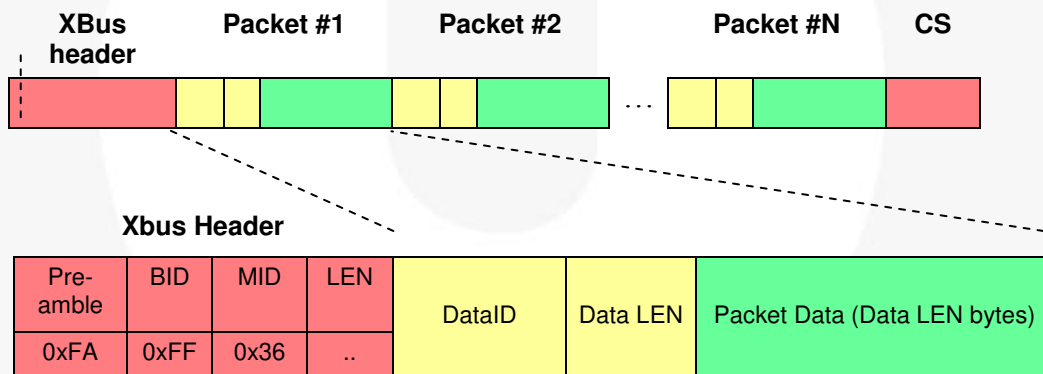

An example data message is depicted below (explanation of the message, divided into parts, in the table):

FA FF 36 35 10 20 02 51 BC 10 60 04 00 21 49 AF 40 10 0C 39 B9 D8 00 B7 DD 80 00 3C C9 26 98 80 30 10 3F 80 00 01 B6 ED 60 01 36 94 A0 00 36 1E 60 00 E0 20 04 00 00 00 87 A0

**Table 20. Example Data Message**

Part of Message (0x)	Meaning
FA FF 36 35	Xbus Header with total length of message (0x35)
10 20 02 51 BC	DataID 0x1020 (Packet counter), length 0x02, data (0x51 BC)
10 60 04 00 21 49 AF	DataID 0x1060 (Sample Time fine), length 0x04, data
40 10 0C 39 B9 D8 00 B7 DD 80 00 3C C9 26 98	DataID 0x4010 (velocity increment), length 0x0C, data
80 30 10 3F 80 00 01 B6 ED 60 01 36 94 A0 00 36 1E 60 00	DataID 0x8030 (orientation increment), length 0x10, data
E0 20 04 00 00 00 87	DataID 0xE020 (StatusWord), length 0x04, data
A0	Checksum

## 6.4 Synchronization and Timing

The FMT1000-series modules can easily be synchronized with other sensors or sensor systems. The FMT accepts a pulse and can then transmit the latest available data. This SYNC\_IN functionality does not influence the accuracy of the data as internally the FMT1000-series keeps estimating the orientation at its maximum frequency. Acceleration data and rate of turn data is also outputted with the shortest possible latency.

The Sync Settings are set with the SetSyncSettings message:

### SetSyncSettings

MID 44 (0x2C)

DATA Setting List (N\*12 bytes)

Set the synchronization settings of the device

### Settings

Each setting describes either a system event that should trigger a sync in event that should trigger a system action.

**Table 21. SYNC\_IN Setting**

Offset (bytes)	Setting	Size (bytes)	Description
0	Function	1	Value 8: Send Latest
1	Line	1	Value 2: SYNC_IN
2	Polarity	1	Which line transition to respond to? One of: Rising Edge (1), Falling Edge (2) or Both (3)
3			Ignored for FMT1000-series
4	Skip First	2	The number of initial events to skip before taking action.
6	Skip Factor	2	The number of events to skip after taking the action before taking action again.
8			Ignored for FMT1000-series
10	Delay	2	Delay after receiving a sync pulse to taking action (100 $\mu$ s units, range [0..60000])



## 7 Magnetic Interference

Magnetic interference can be a major source of error for the heading accuracy of any Attitude and Heading Reference System (AHRS). As an AHRS uses the magnetic field to reference the dead-reckoned orientation on the horizontal plane with respect to the (magnetic) North, a severe and prolonged distortion in that magnetic field will cause the magnetic reference to be inaccurate. The FMT1000-series module has several ways to cope with these distortions to minimize the effect on the estimated orientation.

### 7.1 Magnetic Field Mapping

When the distortion is deterministic, i.e. when the distortion moves with the FMT, the FMT can be calibrated for this distortion this type of errors are usually referred to as soft and hard iron distortions.

The Magnetic Field Mapping procedure compensates for both hard-iron and soft-iron distortions.

In short, the magnetic field mapping (calibration) is performed by moving the FMT together with the object/platform that is causing the distortion. On an external computer (Windows or Linux), the results are processed and the updated magnetic field calibration values are written to the non-volatile memory of the FMT1000-series module. The magnetic field mapping procedure is extensively documented in the Magnetic Field Mapper User Manual, available in the Fairchild MT Software Suite.

### 7.2 Active Heading Stabilization (AHS)

It is often not possible or wanted to connect the FMT1000-series module to a high-level processor/host system, this makes the use of the Magnetic Field Mapping procedure less desirable and cumbersome. Also, when the distortion is non-deterministic the Magnetic Field Mapping procedure does not yield the desired result. For all these situations, the on-board XKF3 sensor fusion algorithm has integrated an algorithm called Active Heading Stabilization (AHS).

The AHS algorithm delivers excellent heading tracking accuracy, improving heading tracking in almost all cases. There are rare occasions where environmental conditions (e.g. specific movements in combination with specific magnetic distortions) that could lead to a lesser performance than expected. In most cases, heading tracking drift in the FMT1000-series can be as low as 1 deg per hour, while being fully immune to magnetic distortions.

AHS is only available in the **VRU\_general** filter profile. This filter profile is the only filter profile in the FMT1020 VRU and one of the 5 available filter profiles in the FMT1030 AHRS.

## 8 Package and Handling

Note that this is a mechanical shock (g) sensitive device. Proper handling is required to prevent damage to the part.

Note that this is an ESD-sensitive device. Proper handling is required to prevent damage to the part.

Make sure not to apply force on the components of the FMT1000-series module, especially when placing the FMT1000-series module in an IC-socket.

### 8.1 Package Drawing

The FMT1000-series module is compatible with JEDEC PLCC28 IC-sockets. For detailed information on the package of the FMT1000, review the package documentation, available on the Fairchild website: MKT-FMT28Arev1.

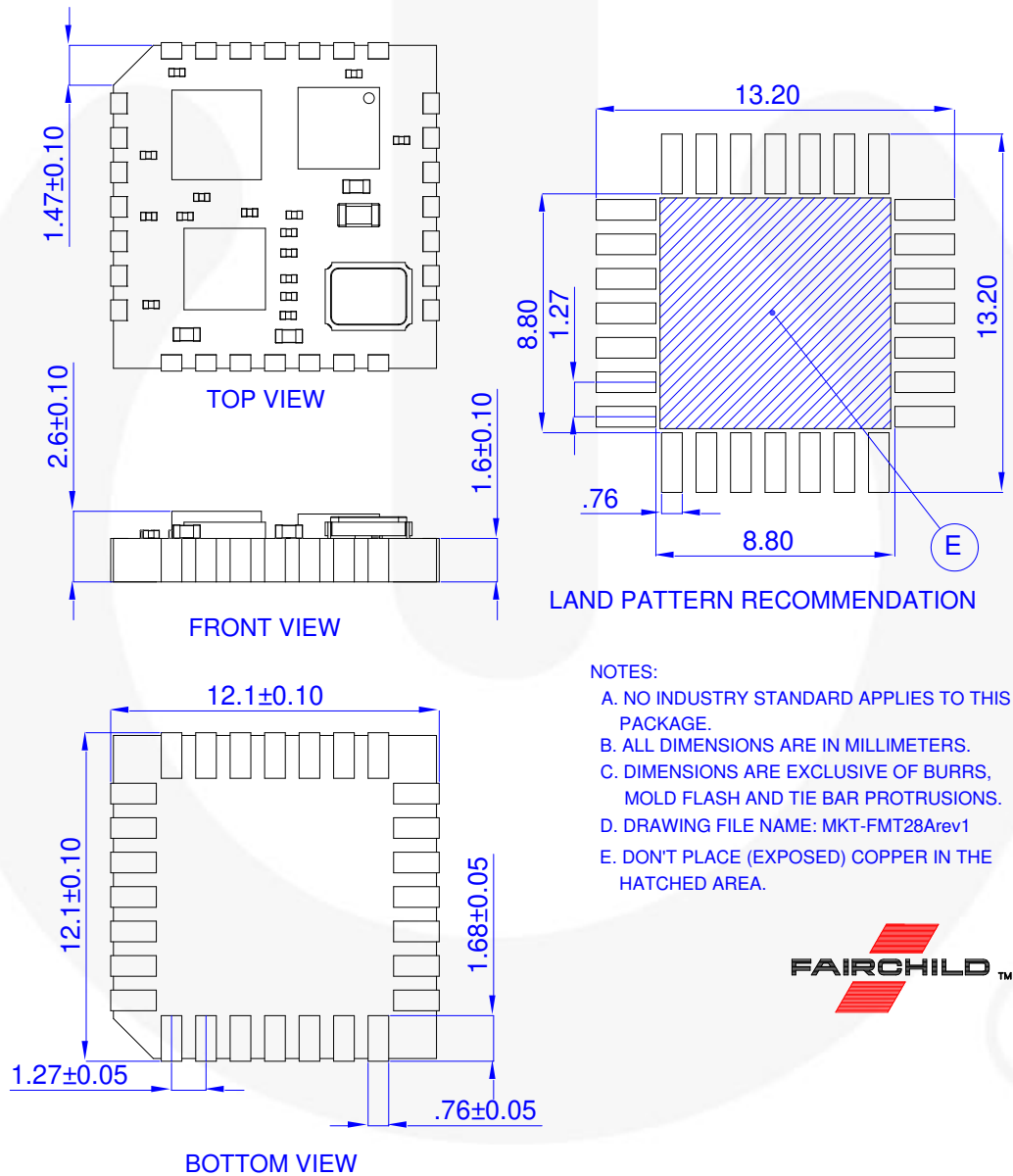

Figure 17. FMT28\_028 Package

Below is the Land Pattern Recommendation for the FMT1000-series. In the hatched area, designated with (E), don't place (exposed) copper.

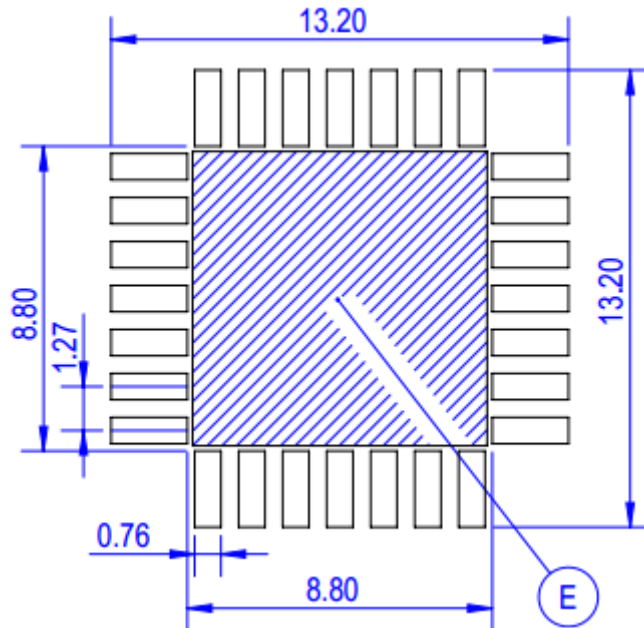

Figure 18. Land Pattern Recommendation

## 8.2 Mounting Considerations

The module contains a Micro Electro Mechanical System (MEMS) chip and is therefore sensitive for stress applied on the PCB. To minimize stress apply the following design rules for the PCB and housing.

Avoid stress on the PCB by screwing/mounting it in a housing, applying unequal or excessive forces to the mounting positions. Ideally the PCB should be mounted using mechanical dampeners.

- Avoid force applied on the PCB by push buttons; connectors etc. close to the FMT1000-series module.
- Avoid heat sources close to the FMT1000-series
- Avoid vibrations caused by speaker, buzzer etc.

### 8.3 Packaging

The FMT1000-series module is shipped in trays or reels. Trays containing 20 modules, according to the configuration below. Reels contain 250 modules. Other quantities and packaging methods are available on request. Packaging details can be found in the packaging specification PKG-FMT28TA on [www.fairchildsemi.com](http://www.fairchildsemi.com).

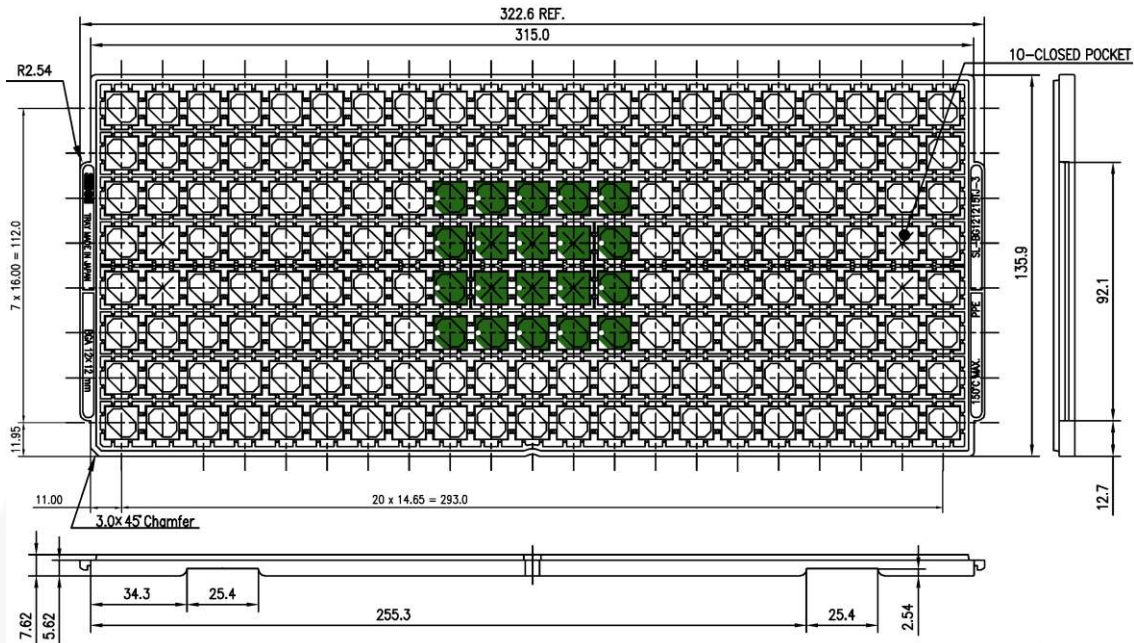

Figure 19. Tray Containing 20ea FMT1000-Series Modules

Reels are packaged according to the specification in PKG-FMT28RA, available on [www.fairchildsemi.com](http://www.fairchildsemi.com).

### 8.4 Reflow Specification

The moisture sensitivity level of the FMT1000-series modules corresponds to JEDEC MSL Level 3, see also:

- IPC/JEDEC J-STD-020E “Joint Industry Standard: Moisture/Reflow Sensitivity Classification for non-hermetic Solid State Surface Mount Devices”
- IPC/JEDEC J-STD-033C “Joint Industry Standard: Handling, Packing, Shipping and Use of Moisture/Reflow Sensitive Surface Mount Devices”.

The sensor fulfils the lead-free soldering requirements of the above-mentioned IPC/JEDEC standard, i.e. reflow soldering with a peak temperature up to 260°C. Recommended Preheat Area ( $t_s$ ) is 80-100 sec. The minimum height of the solder after reflow shall be at least 50  $\mu\text{m}$ . This is required for good mechanical decoupling between the FMT1000-series module and the Printed Circuit Board (PCB) it is mounted on. Assembled PCB's may **NOT** be cleaned with **ultrasonic cleaning**.

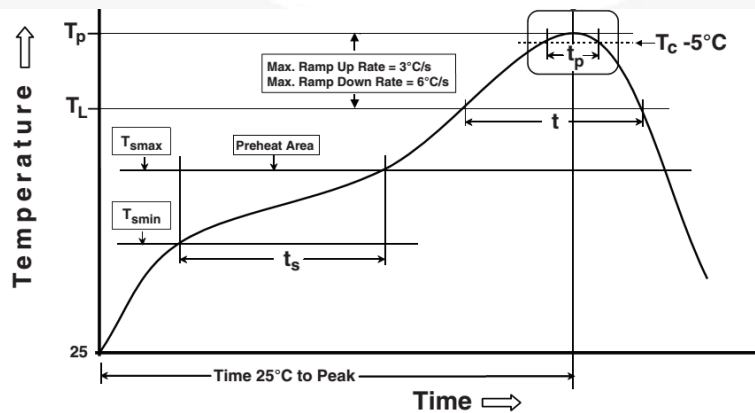

Figure 20. Reflow Profile

IPC-020e-5-1



**TRADEMARKS**

The following includes registered and unregistered trademarks and service marks, owned by Fairchild Semiconductor and/or its global subsidiaries, and is not intended to be an exhaustive list of all such trademarks.

- |                          |  |                                       |                  |
|--------------------------|--|---------------------------------------|------------------|
| AccuPower™               | F-PFS™   | OPTOPLANAR®                           | SYSTEM GENERAL®  |
| AttitudeEngine™          | FRFET®   | Power Supply WebDesigner™             | TinyBoost®       |
| Awinda®                  | Global Power Resource™                         | PowerTrench®                          | TinyBuck®        |
| AX-CAP™*                 | GreenBridge™                                   | PowerXS™                              | TinyCalc™        |
| BitSiC™                  | Green FPS™                                     | Programmable Active Droop™            | TinyLogic®       |
| Build it Now™            | Green FPS™ e-Series™                           | QFET®                                 | TINYOPTO™        |
| CorePLUS™                | Gmax™  | QS™                                   | TinyPower™       |
| CorePOWER™               | GTO™   | Quiet Series™                         | TinyPWM™         |
| CROSSVOLT™               | IntelliMAX™                                    | RapidConfigure™                       | TinyWire™        |
| CTL™                     | ISOPLANAR™                                     | Saving our world, 1mW/W/kW at a time™ | TranSiC™         |
| Current Transfer Logic™  | Making Small Speakers Sound Louder and Better™ | SignalWise™                           | TriFault Detect™ |
| DEUXPEED®                | MegaBuck™                                      | SmartMax™                             | TRUECURRENT®*    |
| Dual Cool™               | MICROCOUPLER™                                  | SMART START™                          | µSerDes™         |
| EcoSPARK®                | MicroFET™                                      | Solutions for Your Success™           | UHC™             |
| EfficientMax™            | MicroPak™                                      | SPM®                                  | Ultra FRFET™     |
| ESBC™                    | MicroPak2™                                     | STEALTH™                              | UniFET™          |
| F <sup>®</sup>           | MillerDrive™                                   | SuperFET®                             | VCX™             |
| Fairchild®               | MotionMax™                                     | SuperSOT™-3                           | VisualMax™       |
| Fairchild Semiconductor® | MotionGrid®                                    | SuperSOT™-6                           | VoltagePlus™     |
| FACT Quiet Series™       | MTI®   | SuperSOT™-8                           | XS™              |
| FACT®                    | MTX®   | SupreMOS®                             | Xsens™           |
| FastvCore™               | MVN®   | SyncFET™                              | 仙童®              |
| FETBench™                | mWSaver®                                       | Sync-Lock™                            |                  |
| FPS™                     | OptoHiT™                                       |                                       |                  |
|                          | OPTOLOGIC®                                     |                                       |                  |

\* Trademarks of System General Corporation, used under license by Fairchild Semiconductor.

**DISCLAIMER**

FAIRCHILD SEMICONDUCTOR RESERVES THE RIGHT TO MAKE CHANGES WITHOUT FURTHER NOTICE TO ANY PRODUCTS HEREIN TO IMPROVE RELIABILITY, FUNCTION, OR DESIGN. TO OBTAIN THE LATEST, MOST UP-TO-DATE DATASHEET AND PRODUCT INFORMATION, VISIT OUR WEBSITE AT [HTTP://WWW.FAIRCHILDSEMI.COM](http://www.fairchildsemi.com). FAIRCHILD DOES NOT ASSUME ANY LIABILITY ARISING OUT OF THE APPLICATION OR USE OF ANY PRODUCT OR CIRCUIT DESCRIBED HEREIN; NEITHER DOES IT CONVEY ANY LICENSE UNDER ITS PATENT RIGHTS, NOR THE RIGHTS OF OTHERS. THESE SPECIFICATIONS DO NOT EXPAND THE TERMS OF FAIRCHILD'S WORLDWIDE TERMS AND CONDITIONS, SPECIFICALLY THE WARRANTY THEREIN, WHICH COVERS THESE PRODUCTS.

**AUTHORIZED USE**

Unless otherwise specified in this data sheet, this product is a standard commercial product and is not intended for use in applications that require extraordinary levels of quality and reliability. This product may not be used in the following applications, unless specifically approved in writing by a Fairchild officer: (1) automotive or other transportation, (2) military/aerospace, (3) any safety critical application – including life critical medical equipment – where the failure of the Fairchild product reasonably would be expected to result in personal injury, death or property damage. Customer's use of this product is subject to agreement of this Authorized Use policy. In the event of an unauthorized use of Fairchild's product, Fairchild accepts no liability in the event of product failure. In other respects, this product shall be subject to Fairchild's Worldwide Terms and Conditions of Sale, unless a separate agreement has been signed by both Parties.

**ANTI-COUNTERFEITING POLICY**

Fairchild Semiconductor Corporation's Anti-Counterfeiting Policy. Fairchild's Anti-Counterfeiting Policy is also stated on our external website, [www.fairchildsemi.com](http://www.fairchildsemi.com), under Terms of Use

Counterfeiting of semiconductor parts is a growing problem in the industry. All manufacturers of semiconductor products are experiencing counterfeiting of their parts. Customers who inadvertently purchase counterfeit parts experience many problems such as loss of brand reputation, substandard performance, failed applications, and increased cost of production and manufacturing delays. Fairchild is taking strong measures to protect ourselves and our customers from the proliferation of counterfeit parts. Fairchild strongly encourages customers to purchase Fairchild parts either directly from Fairchild or from Authorized Fairchild Distributors who are listed by country on our web page cited above. Products customers buy either from Fairchild directly or from Authorized Fairchild Distributors are genuine parts, have full traceability, meet Fairchild's quality standards for handling and storage and provide access to Fairchild's full range of up-to-date technical and product information. Fairchild and our Authorized Distributors will stand behind all warranties and will appropriately address any warranty issues that may arise. Fairchild will not provide any warranty coverage or other assistance for parts bought from Unauthorized Sources. Fairchild is committed to combat this global problem and encourage our customers to do their part in stopping this practice by buying direct or from authorized distributors.

**PRODUCT STATUS DEFINITIONS**

**Definition of Terms**

Datasheet Identification	Product Status	Definition
Advance Information	Formative / In Design	Datasheet contains the design specifications for product development. Specifications may change in any manner without notice.
Preliminary	First Production	Datasheet contains preliminary data; supplementary data will be published at a later date. Fairchild Semiconductor reserves the right to make changes at any time without notice to improve design.
No Identification Needed	Full Production	Datasheet contains final specifications. Fairchild Semiconductor reserves the right to make changes at any time without notice to improve the design.
Obsolete	Not In Production	Datasheet contains specifications on a product that is discontinued by Fairchild Semiconductor. The datasheet is for reference information only.

Rev. 177