

6

5

4

3

2

1

FRONT VIEW - FEMALE INSERT

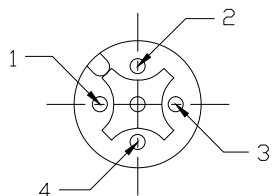

- 1 - RED
- 2 - RED/WHITE
- 3 - RED/BLACK
- 4 - GREEN

1.23 [31.2] REF.

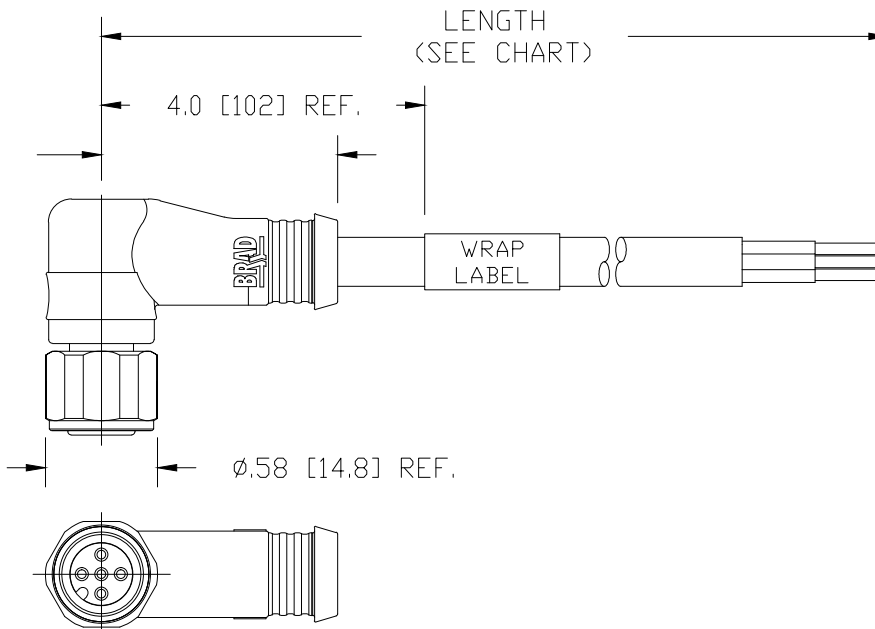

NOTES:

MATERIALS:  
 CONTACTS: COPPER ALLOY, GOLD/NICKEL PLATING  
 CONTACT CARRIER: NYLON, BLACK  
 MOLDED BODY: PVC, YELLOW  
 COUPLER: 316 STAINLESS STEEL

ELECTRICAL:  
 CURRENT RATING: 4AMP MAX  
 VOLTAGE RATING: 250V

MECHANICAL:  
 TEMPERATURE: -20° TO 80°C  
 INGRESS PROTECTION: IP67

CABLE SPECIFICATIONS:  
 CABLE JACKET: PVC, YELLOW  
 CONDUCTORS: #18/4, PVC

|             |                 |                                  |
|-------------|-----------------|----------------------------------|
| PART NUMBER | ENGINEERING NO. | LENGTH                           |
| 1200652169  | 804001A03M0208  | 6.56' +3.50" -0 [ 2.0M +89mm -0] |

CUSTOMER PRODUCTION APPROVAL  
 APPROVED BY: \_\_\_\_\_  
 DATE: \_\_\_\_\_  
 MUST BE SIGNED AND RETURNED BEFORE  
 PRODUCTION WILL BEGIN.

RESTRICTED SALES DRAWING

|   |                            |             |
|---|----------------------------|-------------|
| CORRECT COLOR CODE<br>EC NO: WEU2010-0539<br>DRWN: LHARTMAN 5/7/10<br>CHKD: TWOLDEGE<br>APPR: JFMURPHY 2010/02/10 | QUALITY SYMBOLS            | DESCRIPTION |
|   | $\nabla=0$<br>$\nabla/C=0$ |             |

|  |                             |
|--|-----------------------------|
| GENERAL TOLERANCES (UNLESS SPECIFIED)                |                             |
|  | DIMENSION STYLE INCH ONLY   |
|  | SCALE 1:1 DESIGN UNITS INCH |
|  | THIRD ANGLE PROJECTION      |
| 4 PLACES   | mm INCH                     |
| 3 PLACES   | ±--- ±---                   |
| 2 PLACES   | ±--- ±.005                  |
| 1 PLACE  | ±--- ±.010                  |
| ANGULAR ±---°  |                             |
| DRAFT WHERE APPLICABLE MUST REMAIN WITHIN DIMENSIONS |                             |

|              |            |
|--------------|------------|
| DRAWN BY     | DATE       |
| LHARTMAN     | 2010/01/05 |
| CHECKED BY   | DATE       |
| TWOLDEGE     | 2010/01/15 |
| APPROVED BY  | DATE       |
| JFMURPHY     | 2010/02/10 |
| MATERIAL NO. | SEE TABLE  |
| SIZE         | A          |

|   |               |
|---|---------------|
| TITLE   |               |
| MICRO CHANGE PORTABLE 4-POLE FEMALE 90DEGREE #18/4 YELLOW PVC CABLE   |               |
| MOLEX INCORPORATED  |               |
| DOCUMENT NO.  | SD-120065-025 |
| SHEET NO.   | 1 OF 1        |
| THIS DRAWING CONTAINS INFORMATION THAT IS PROPRIETARY TO MOLEX INCORPORATED AND SHOULD NOT BE USED WITHOUT WRITTEN PERMISSION |               |

6

5

4

3

2

1