

REV	DESCRIPTION	DATE	APP
00	NEW DWG	01/08/18	

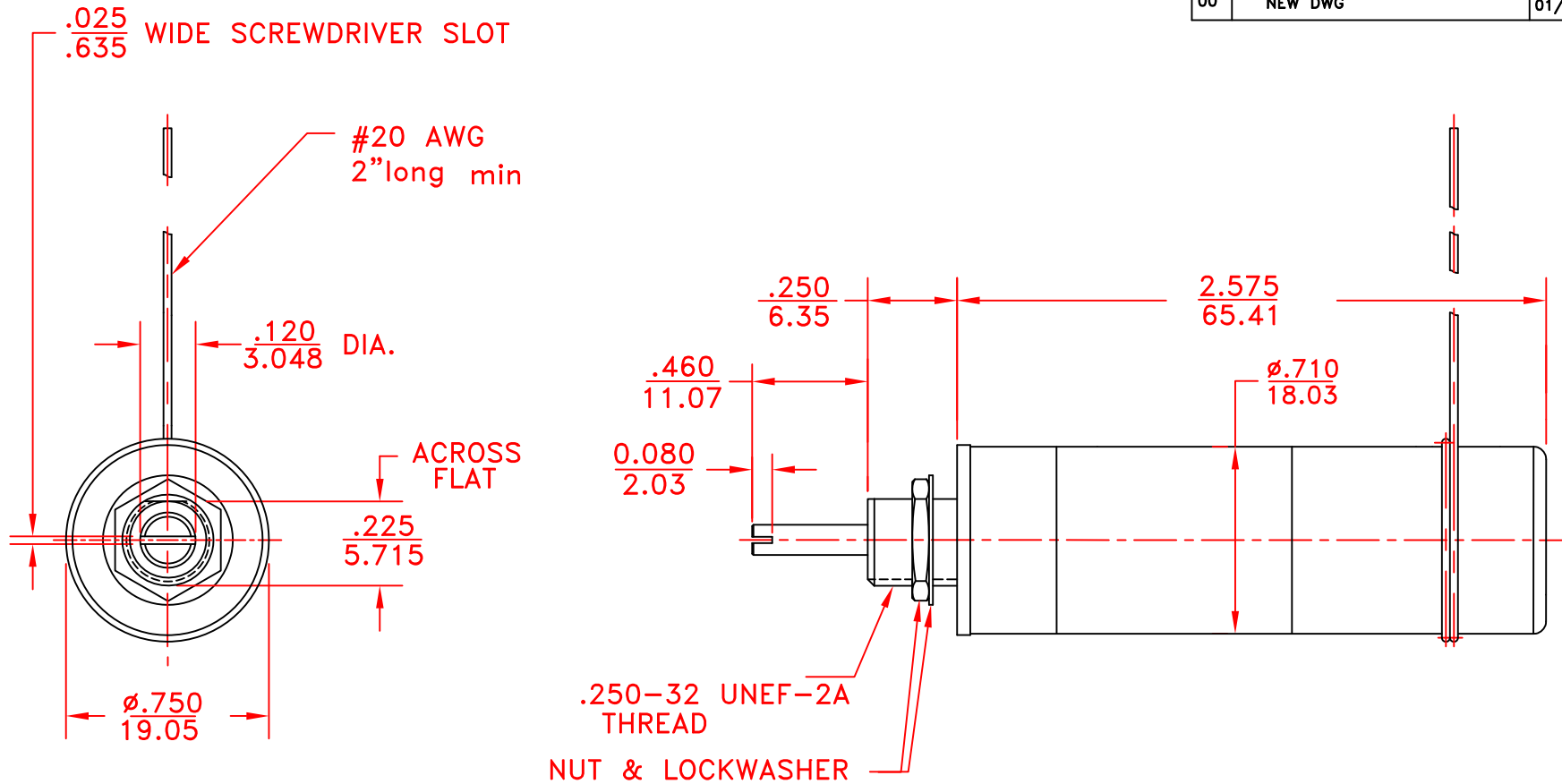

NOTES:

1. CAPACITANCE: $C_{max} \geq 70$ pF, $C_{min} \leq 4.0$ pF.
2. WORKING VOLTAGE : 10000 VDC.
3. WITHSTANDING VOLTAGE : 20000 VDC.
4. $Q \geq 600$ @ 25MHZ
5. TORQUE: 0.5 TO 5.0 oz-in.
6. OPERATING TEMPERATURE : -55°C TO 125°C
7. CONSTRUCTION : 40 psi SEALED, NON-MAGNETIC.
8. DIMENSIONS IN INCHES/MM.
9. ROTATIONAL LIFE: 10,000 TURNS

TOLERANCES: (EXCEPT AS NOTED)	SPRAGUE GOODMAN ELECTRONICS INC. 1700 SHAMES DRIVE WESTBURY, NY 11590		
DECIMAL: $\pm .005$ in $\pm .130$ mm	MATERIAL:	SCALE: NONE	DRAWN BY: R. LEVIN APPROVED: I. DITLYA
FRACTIONAL: 1/64	TITLE: SGNMNC70-10E		USED FOR:
ANGULAR: 1°	DATE: 01/08/2018	DRAWING NUMBER SGNM70-10E	REV. 00