

RIGHT ANGLE PLUG SOLDER TYPE

R124.153.001

CABLE .085

Series : SMA-COM

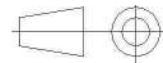
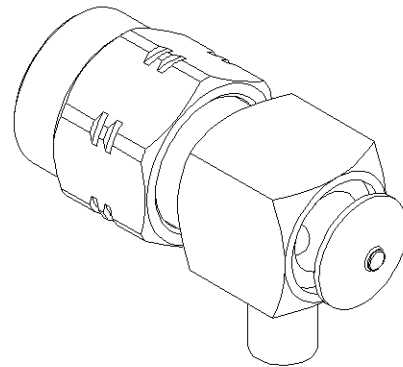
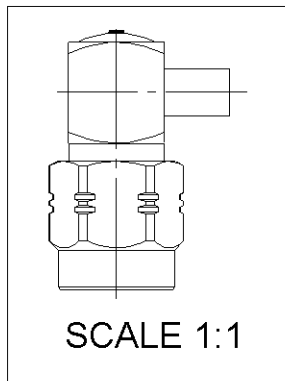
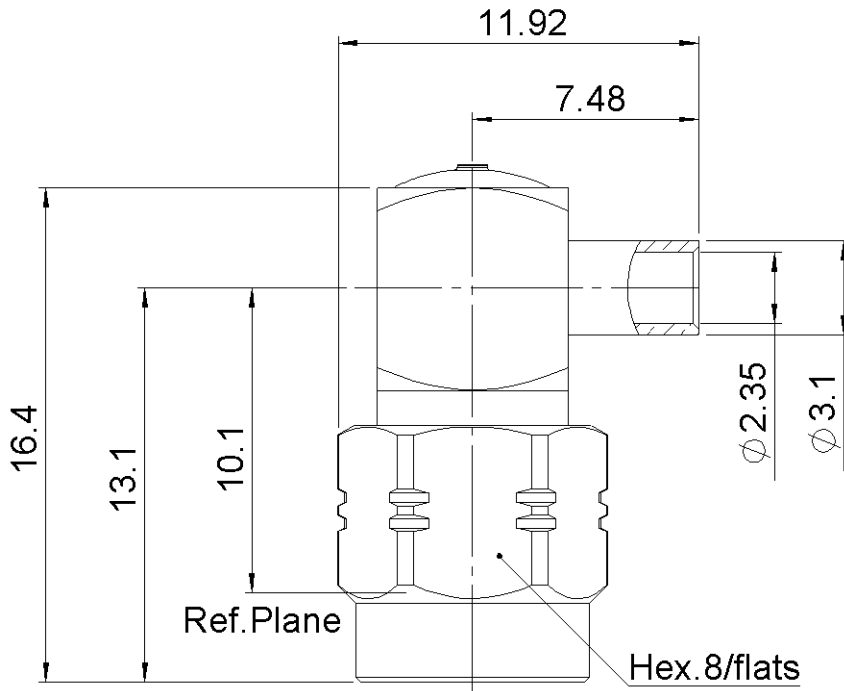

All dimensions are in mm.

COMPONENTS	MATERIALS	PLATING (µm)
BODY	BRASS	BBR
CENTER CONTACT	BRASS	-
OUTER CONTACT	-	--
INSULATOR	-	
GASKET	SILICONE RUBBER	
OTHERS PARTS	BRASS	BBR
-	-	-
-	-	-

Issue : 1151 B

In the effort to improve our products, we reserve the right to make changes judged to be necessary.



RIGHT ANGLE PLUG SOLDER TYPE

R124.153.001

CABLE .085

Series : SMA-COM

PACKAGING

Standard	Unit	Other
100	'W' option	Contact us

SPECIFICATION

ELECTRICAL CHARACTERISTICS

Impedance		50 Ω
Frequency		0-12.4 GHz
VSWR	1.10 +	0,0100 x F(GHz) Maxi
Insertion loss		0.05 √F(GHz) dB Maxi
RF leakage	- (90 - F(GHz)) dB Maxi
Voltage rating		335 Veff Maxi
Dielectric withstanding voltage		750 Veff mini
Insulation resistance		5000 MΩ mini

CABLE ASSEMBLY

Stripping	a	b	c	d	e	f
mm	3,17	0,00	0,00	0,00	0,00	0,00

Assembly instruction : **Solder 02**

Recommended cable(s)
RG 405
KS 1

Characteristics indicated on this data sheet are those that can be achieved with the highest performance cable. Intrinsic limitations of the cable may diminish the performance of the assembly

Cable retention

- pull off **130** N mini
- torque **NA** N.cm

MECHANICAL CHARACTERISTICS

Center contact retention		
Axial force – Mating end	27	N mini
Axial force – Opposite end	27	N mini
Torque	NA	N.cm mini

TOOLING

Part Number	Description	Hexagon
.	.	.
R282.051.000	STRIPPING TOOL	
R282.063.000	POINTER GAUGE	
R282.740.000	SOLDERING MOUNTING	
R282.744.201	SOLDERING POSITIONER	

Recommended torque		
Mating	60	N.cm
Panel nut	NA	N.cm
Clamp nut	NA	N.cm
A/F clamp nut	0,0000	mm

Mating life	100	Cycles mini
Weight	4,0500	g

OTHER CHARACTERISTICS

-

ENVIRONMENTAL

Operating temperature	-65/+105	° C
Hermetic seal	NA	Atm.cm3/s
Panel leakage	NA	

Issue : 1151 B

In the effort to improve our products, we reserve the right to make changes judged to be necessary.

