

VICOR CONFIDENTIAL
 THIS DOCUMENT AND THE DATA DISCLOSED HEREIN OR
 HEREWITH IS NOT TO BE REPRODUCED, USED OR
 DISCLOSED IN WHOLE OR IN PART TO ANYONE WITHOUT
 THE PERMISSION OF VICOR CORP.

REV.	DESCRIPTION	DATE	APPROVED
3	RELEASED PER E090033	AR 01/09/09	REJH
4	REVISED PER E091548	JS 09/03/09	REJH
5	REDRAWN PER E100887	DCS 06/31/10	KUK
6	REVISED PER E111266	VSS 12/22/11	REJH

F

E

D

C

B

A

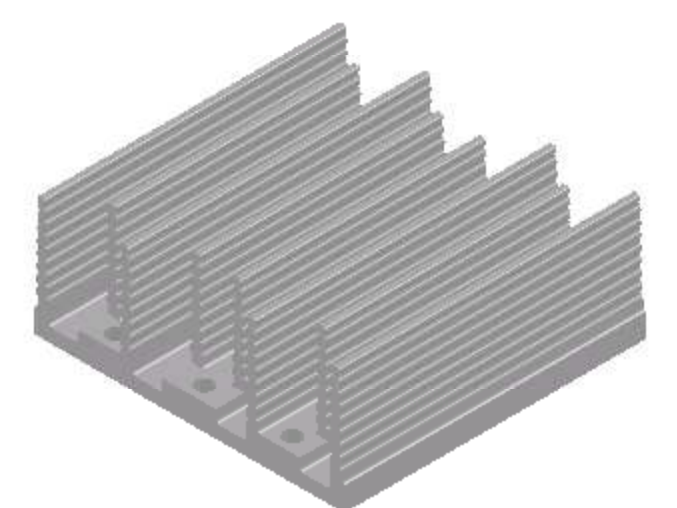
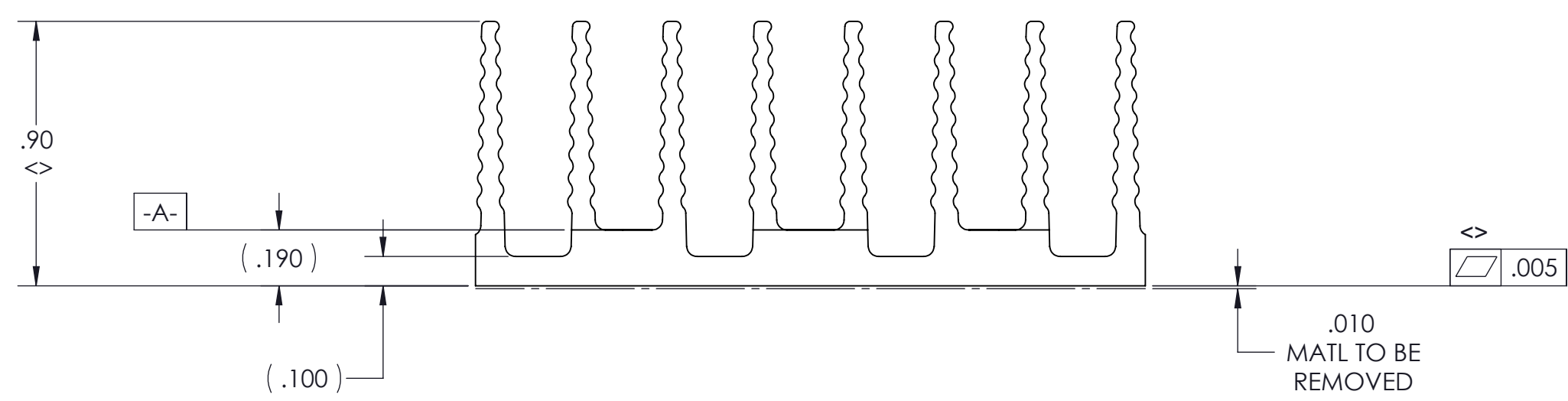
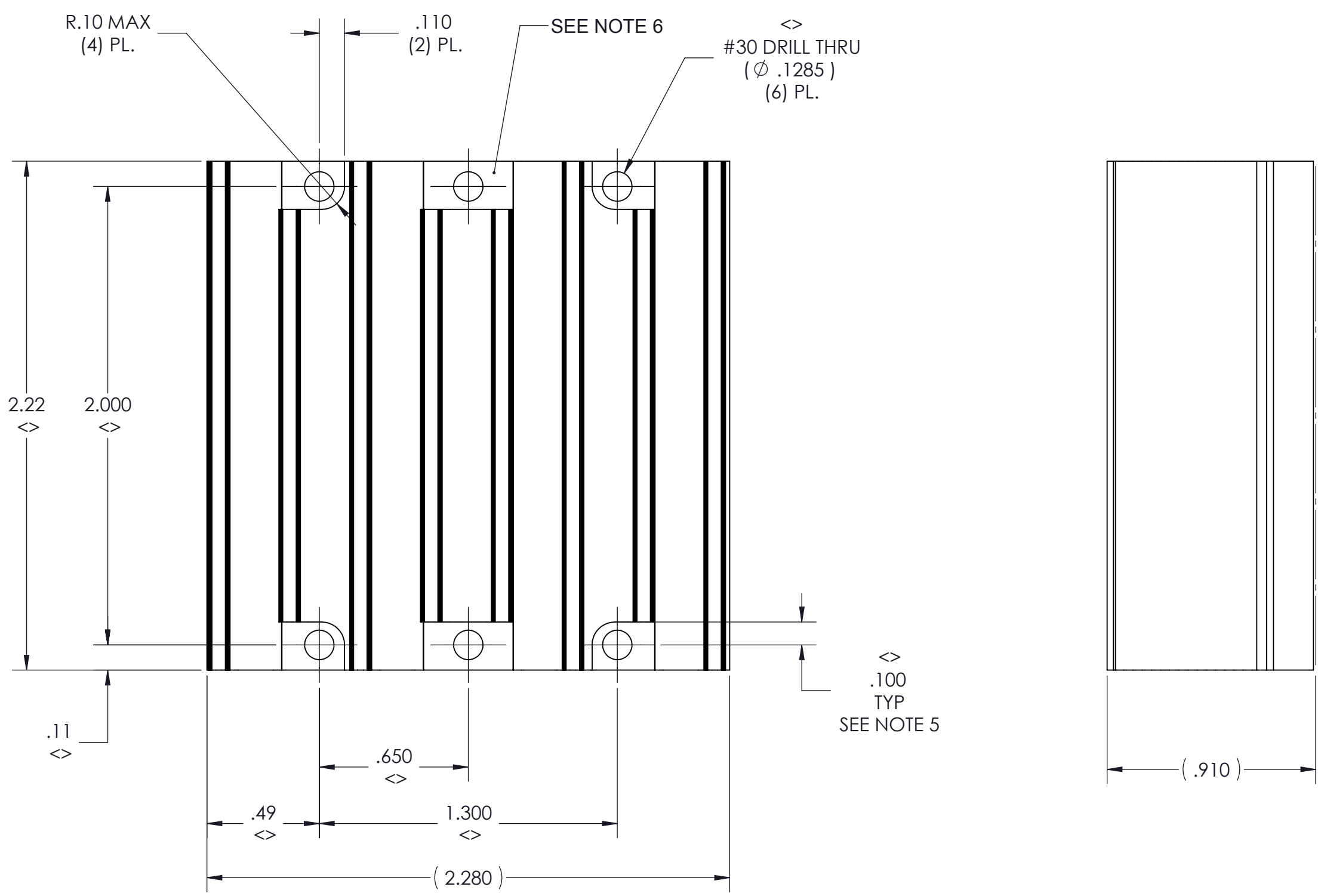

- NOTES:
1. MATERIAL: EXTRUSION SEE SHEET 2 OF 2
 2. REMOVE ALL BURRS AND SHARP EDGES.
 3. CLEAR FINISH, RoHS COMPLAINT PER CST-0001, LATEST REVISION PER
 A) CHROMIUM FREE, OR
 B) TRIVALENT CHROMIUM IN ACCORDANCE WITH MIL-DTL-5541, TYPE II, CLASS 1A OR 3.
 SEE CST-0003 FOR TYPES OF AVAILABLE FINISHES.
 4. "<>" DENOTES CRITICAL CHARACTERISTIC FOR LOT INSPECTION.
 5. DIMENSIONS APPLIES AT SURFACE -A- (2) PL.
 6. MACHINED SURFACE TO BE .010 MAX BELOW SURFACE -A- (6) PL.
 7. DIMENSIONS ARE INCHES ONLY.

DRAWN BY David Schmidt	DATE 06/23/2010	VICOR SWD	
UNLESS OTHERWISE SPECIFIED DIMENSIONS ARE : INCH / (MM)		HS XF 22.86MM CFG "B"	
TOLERANCES ARE: DECIMALS ANGLES X.XX [X.X] = ±0.01 [0.25] ±1° X.XXX [X.XX] = ±0.005 [0.127]		SIZE C	CAGE CODE 67131
THIRD ANGLE PROJECTION  DO NOT SCALE DRAWING		DWG NO 30724	REV 6
SCALE 2:1		SHEET 1 OF 2	

8

7

6

5

4

3

2

1

VICOR CONFIDENTIAL
 THIS DOCUMENT AND THE DATA DISCLOSED HEREIN OR
 HEREWITH IS NOT TO BE REPRODUCED, USED OR
 DISCLOSED IN WHOLE OR IN PART TO ANYONE WITHOUT
 THE PERMISSION OF VICOR CORP.

REV.	DESCRIPTION	DATE	APPROVED
	SEE SHEET 1 OF 2		

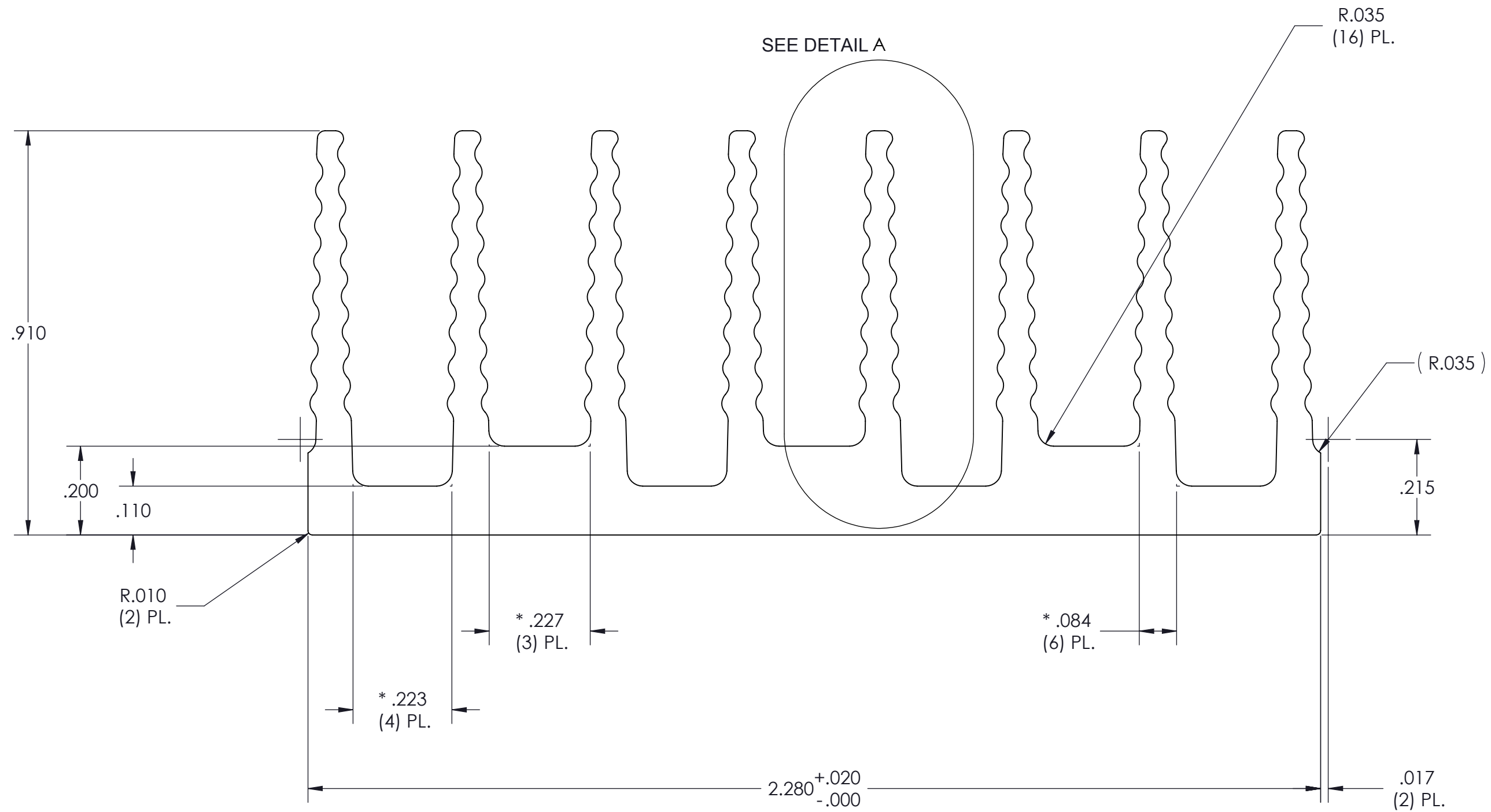

PROFILE COMMON FOR
30270
30724
30269
30725

- NOTES:
- MATL: ALUMINUM 6063-T5
 - * DENOTES DIMENSION TO THEORETICAL SHARP CORNER.
 - ALL DIMENSIONS ARE CRITICAL CHARACTERISTICS.
 - RoHS COMPLIANT PER CST-0001 LATEST REVISION.
 - WORKMANSHIP STANDARDS WS-0004, WS-0006 AND WS-0007 APPLY TO THIS PART.
 - DIMENSIONS ARE INCHES ONLY.

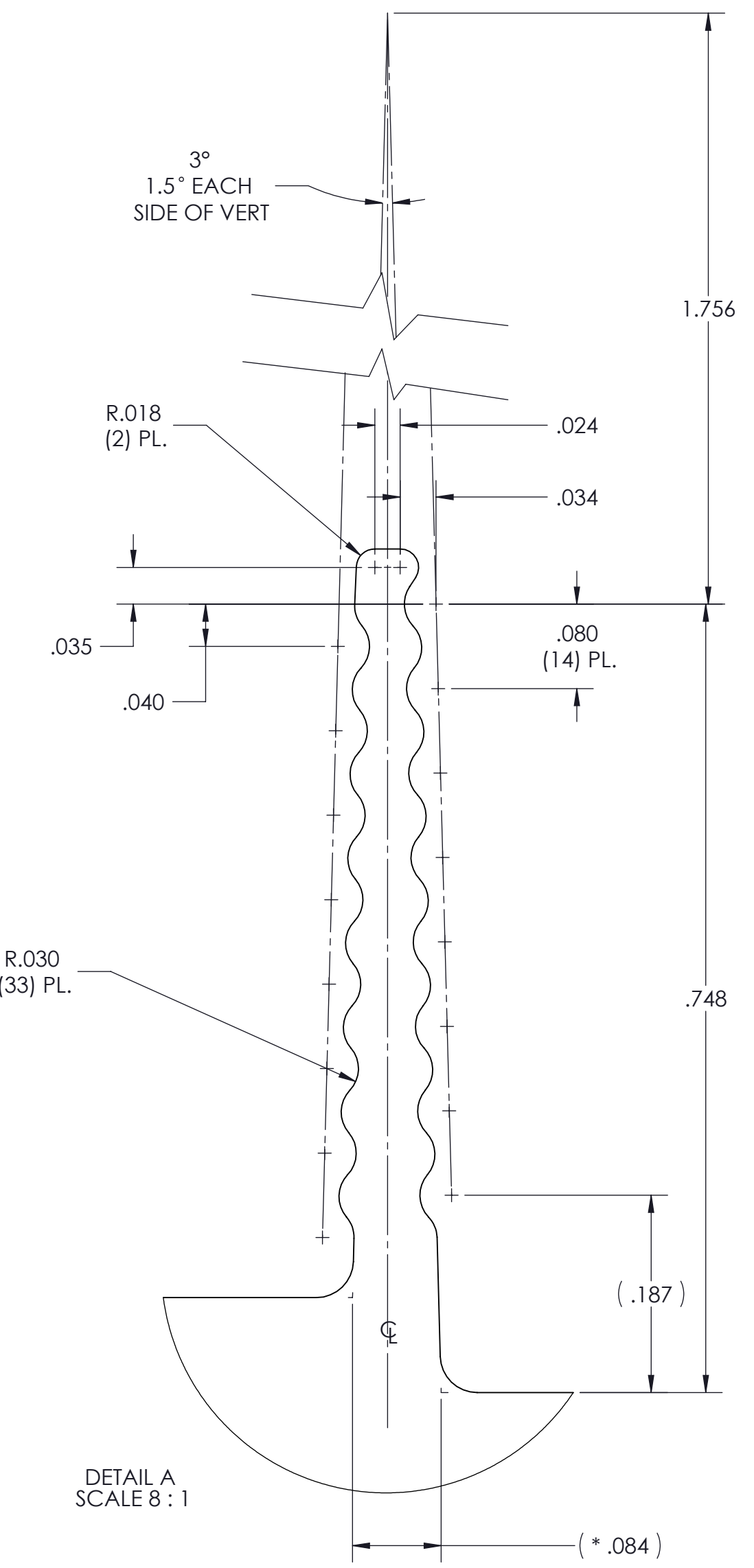

DRAWN BY David Schmidt	DATE 06/23/2010	VICOR SWD		
UNLESS OTHERWISE SPECIFIED DIMENSIONS ARE : INCH / (MM)		HS XF 22.86MM CFG "B"		
TOLERANCES ARE: DECIMALS ANGLES X.XX [X.X] = ±0.01 [0.25] ±1° X.XXX [X.XXX] = ±0.005 [0.127]		SIZE C	CAGE CODE 67131	DWG NO 30724
THIRD ANGLE PROJECTION  DO NOT SCALE DRAWING		SCALE 2:1	REV 6	
		SHEET 2 OF 2		

8

7

6

5

4

3

2

1