

# Ultra small size Adjustable output high voltage power supply 2.5W to 3W Mid-high voltage DC-DC converter

## Bellnix®

# 0V to 180V, 300V, 350V MHV Series

The MHV series is the first high voltage power supply in the industry to use the latest SMT (surface mount technology) making the size 1/5 to 1/6 of the normal product, with an adjustable output voltage type mid-high voltage DC-DC converter. Output voltage can be controlled using an external voltage or external resistor. The MHV series has adopted a 5 sided metallic shield, with lower ripple and lower noise.



### ■ Features

- PCB mounting type
- Output capacity 2.5W to 3W
- Over current protection
- Worlds smallest size
- Low price
- UL certified product (UL File No. E305960)
- Adopted a 5 sided metallic shield case
- 100% Burn in test
- Adjustable voltage using an external voltage
- Low ripple noise of 30mVp-p
- High reliability, long life

### ■ Model/Rating

Model name MHV Series	Input voltage (Vdc)	Output voltage (Vdc) Note1	Output current (mA)	Load resistor (kΩ ) min	Output capacity (W)	Input current (mA) typ	Ripple noise (mVp-p) typ	Case
MHV12-180S15P	10.8 to 13.2	0 to +180	0 to 15	12	2.7	350	30	M-8
MHV12-180S15N	10.8 to 13.2	0 to -180	0 to 15	12	2.7	350	30	M-8
MHV12-300S10P	10.8 to 13.2	0 to +300	0 to 10	30	3.0	395	30	M-8
MHV12-300S10N	10.8 to 13.2	0 to -300	0 to 10	30	3.0	395	30	M-8
MHV12-350S07P	10.8 to 13.2	0 to +350	0 to 7	50	2.5	330	30	M-8
MHV12-350S07N	10.8 to 13.2	0 to -350	0 to 7	50	2.5	330	30	M-8

### ■ Specifications

Line regulation	0.02% typ.(Input current varying from +10.8V to +13.2V)
Load regulation	180V type : 0.5% typ. 300V, 350V type : 0.2% typ.(Load current varying from 0% to 100%)
Temp regulation	± 0.01%/°C typ.(Temp varying from -10°C to +50°C)
Over current protection	Letter 7 characteristic, auto restart circuit at 105% or more
Output voltage accuracy	Below ± 5% (Rated output, rated load, and Vcont=4.0V)
Output voltage control	External voltage 0V to +4V or an external resistor 5KΩ to adjust
Usage temp range	-10°C to +60°C(Derating required for temp higher than +50°C)
Storage temp range	-25°C to +85°C
Usage humidity range	20% to 95%RH(no dewing)
Isolation between input/output	Non isolated type (2pin-5pin and the case are connected internally)
MTBF expected value	480,000H min. (Bellnix MTBF formula diagram)

Note1: The output voltage will be controlled by applying the Vcont voltage. Using an adjustable resistor or an external voltage, voltage should be applied on the Vcont pin in order to control the output voltage. When Vcont voltage=0V the output voltage (output residual voltage) should be less than 0.5% of the max output voltage(I/O rated).

### ■ Test circuit

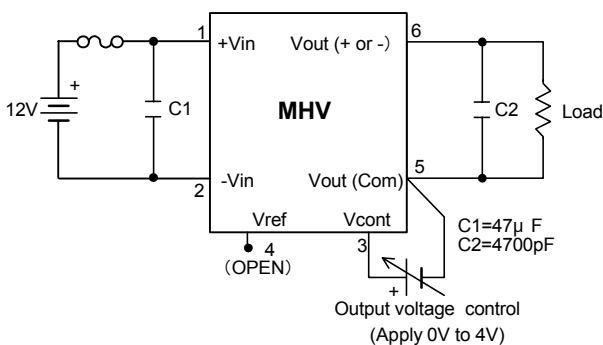

Warning1: The ground line (2pin, 5pin) between the input/output, and the case are internally connected. Warning2: Vref is 4V ±0.3V (When external VR=5KΩ)

### ■ Block diagram

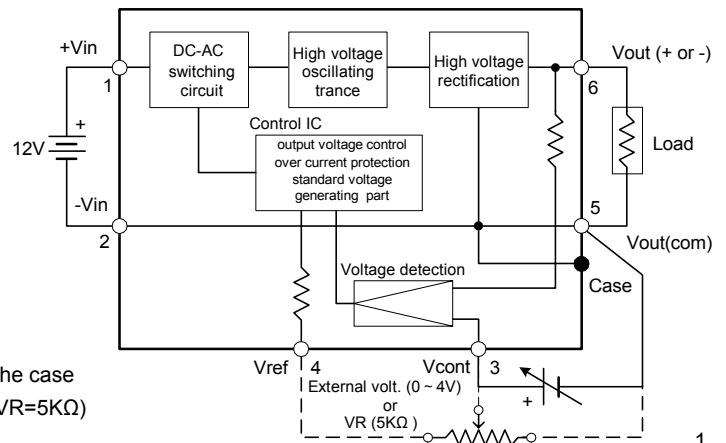

■ Model/Dimensions/Pin configuration (M-8 case)

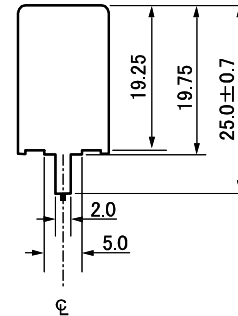
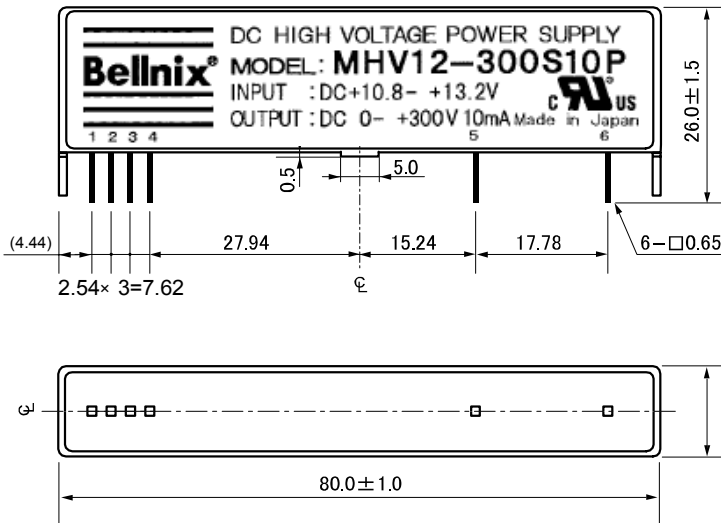

pin-NO.	pin name
1	+Vin
2	-Vin
3	Vcont
4	Vref
5	Vout (com)
6	Vout (+ or -)

1)Pin

Material : Phosphorous bronze  
Treatment : Ni base Au coating

2)Case

Material : Brass  
Treatment : Nickel coating

Weight : 46g typ.  
Unit : mm  
Tolerances unless  
otherwise specified:±0.5

■ Standard usage instructions

MHV Series (180V, 300V, 350V)

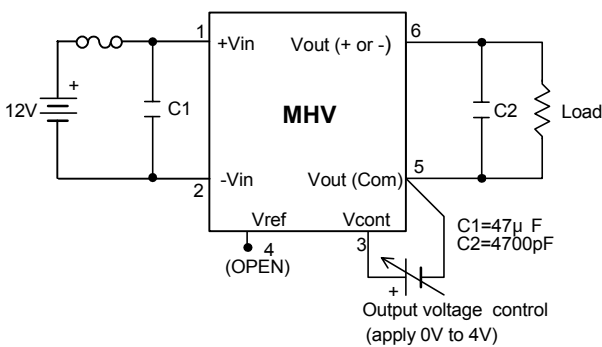

The MHV series does not require any external parts, however when the impedance is high, for example: the distance between the power supply and converter is long, the input line is thin, or the input side has a filter then connecting a capacitor C1 to the input side is recommended.

Place the capacitor as close as possible to the converter pin side, to lower the lead inductance.

■ Over current protection

The MHV series has a over load and load short protection installed, which is the over current protection. When the product status is in over load or load short mode, the output voltage will decrease, and once the problem has been removed, the voltage will increase again.

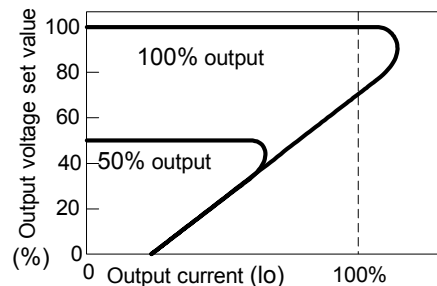

MHV series  
Over current protection  
characteristic

## Recommended pin pattern

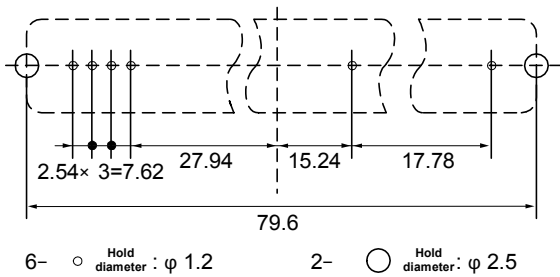

① The MHV series uses a metallic case. When soldering to a double-sided PCB, the wiring for the converter should be on the soldering side.

Also, this converter will generate high voltages so the creepage distance should also be taken into account when designing.

② When mounting to a double-sided PCB, the high voltage output pin and land should be as small as possible.

③ The MHV series case should be connected to the -Vin and Vout (Com).

④ The metallic case does not need to be touching anything. However, when using and making contact with the metallic case, the anti land impedance should be lowered.

## Vref pin (standard voltage output)

When controlling the output voltage with an adjustable resistor, this pin is used. Vref has a standard output voltage of 4V. In this case, the external adjustable resistor is 5KΩ. Since the resistance value from the external adjustable resistor will decide the output voltage with the effect of the specified value, use a resistance value with an accuracy of 5KΩ±5%. The type of resistor does not matter, as long as it is 5KΩ, however one with a good temp coefficient is recommended.

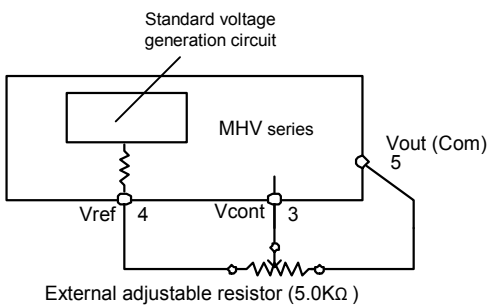

## Setting output voltage and adjusting feature

The MHV series output voltage can be adjusted by using an external voltage or external adjustable resistor.

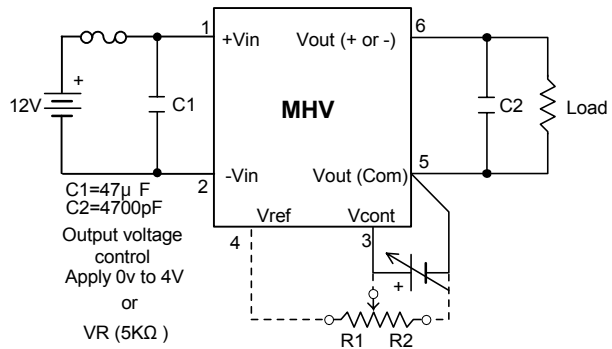

Output voltage- VR resistance value characteristic

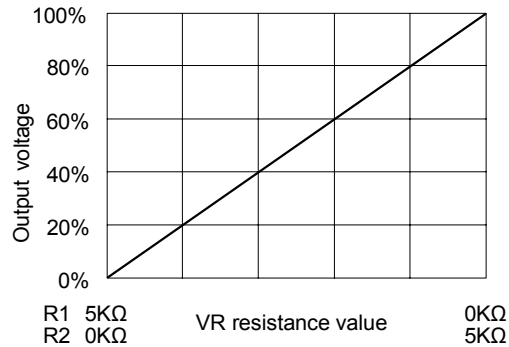

Output voltage- Output control voltage characteristic

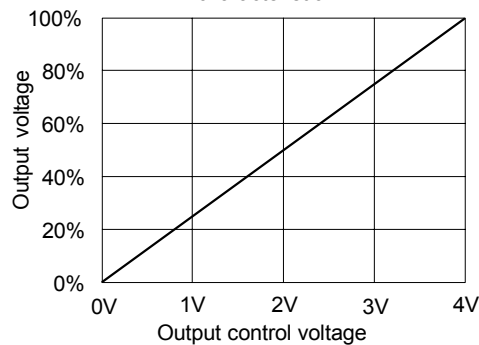

- The above characteristics (Output voltage -VR resistance value characteristic) graph is an indication of the resistance value R1 and R2. When setting the voltage to a set rate using a stable resistor, first decide the adjustable resistor R1 and R2.
- Do not apply voltage higher than 4V+5% on the Vcont.
- Choose an adjustable resistor appliance with good temp characteristics.
- When the resistance value for the adjustable resistor is 5.0KΩ, the max output voltage of 6.0V which is 100%, should be applied to Vcont pin. Since the max output voltage largely affects the margin of error for the resistance value, set the resistance value at 5.0KΩ±5%.

### ■ Temp derating

When using the product where the ambient temp is higher than 50°C, follow the derating graph below, increasing the load resistance as the temp increases. The minimum load resistance value is specified for each series.

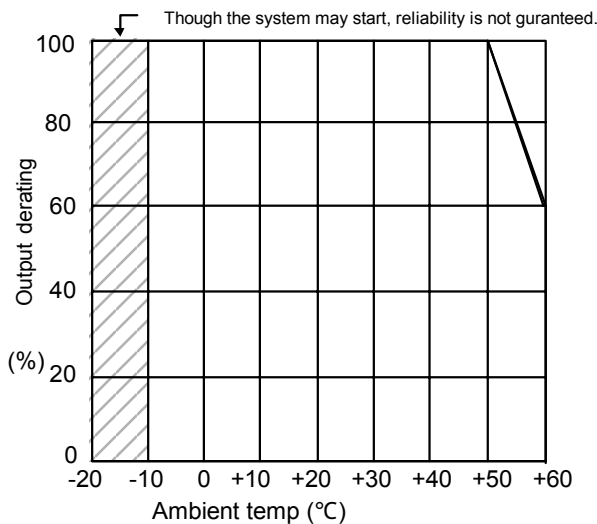

### ■ Preventing reverse connections

The converter may break if the polarities are reversed. If there is a possibility in which the connections maybe reversed, connect a diode and fuse like below.

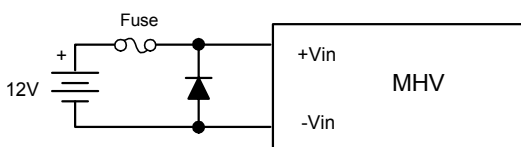

### ■ Recommended solder conditions

Soldering conditions for each part are as follows:

- ① Using a soldering iron      340 to 360°C      5 sec.
- ② Using a soldering tub        230 to 260°C      10 sec.

### ■ Decreasing the output noise further

The MHV series does not need any external parts, however to lower the output noise further, connect a capacitor C2 like the figure below.

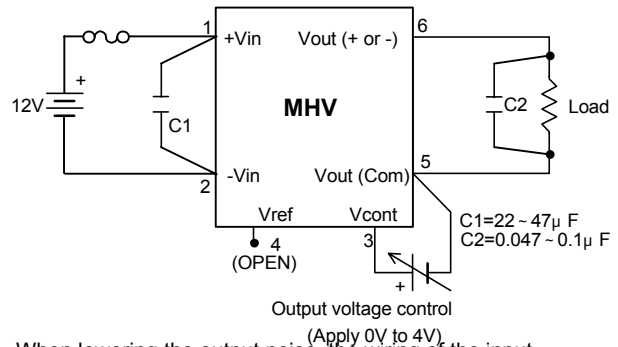

When lowering the output noise, the wiring of the input and output should be as short as possible. Place C2 closest to the load, paying attention to creepage and clearance distances.

#### Point!

- ① Choose a capacitor with a high-frequency when adding to the input.
- ② Earth (COMMON) line should be thick and short in the pattern design to lower the common impedance.
- ③ The capacitor which is connected to the output side should be able to withstand the pressure, when connected to the loadside. At this time, the capacitor lead should be shortened. Also when the load response time is a problem, please be aware of the time constant.

### ■ Safety standards

The MHV series has been certified with the UL / c-UL.

- UL60950-1 1st Ed.
- c-UL(CSA22.2 No.60950-1-03 1st Ed.)

When using this product as a recognized (certified) product, an input fuse should be mounted like below.

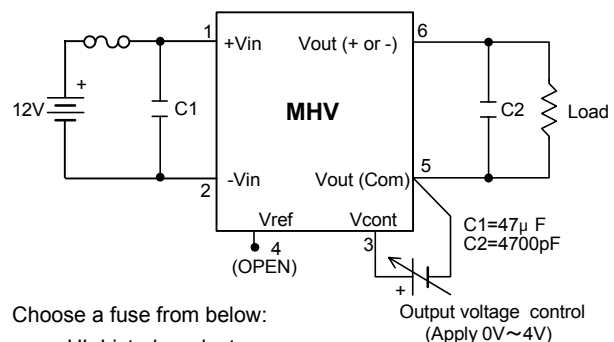

Choose a fuse from below:

- UL Listed products
- DC250V, Rated current 2A type