

THIS DRAWING IS UNPUBLISHED. RELEASED FOR PUBLICATION  
 © COPYRIGHT BY TYCO ELECTRONICS CORPORATION. ALL RIGHTS RESERVED.

LOC	DIST	REVISIONS			
P	LTR	DESCRIPTION	DATE	DWN	APVD
AG	53	K1	REV PER ECO-06-013364	12OCT2006	BC JH

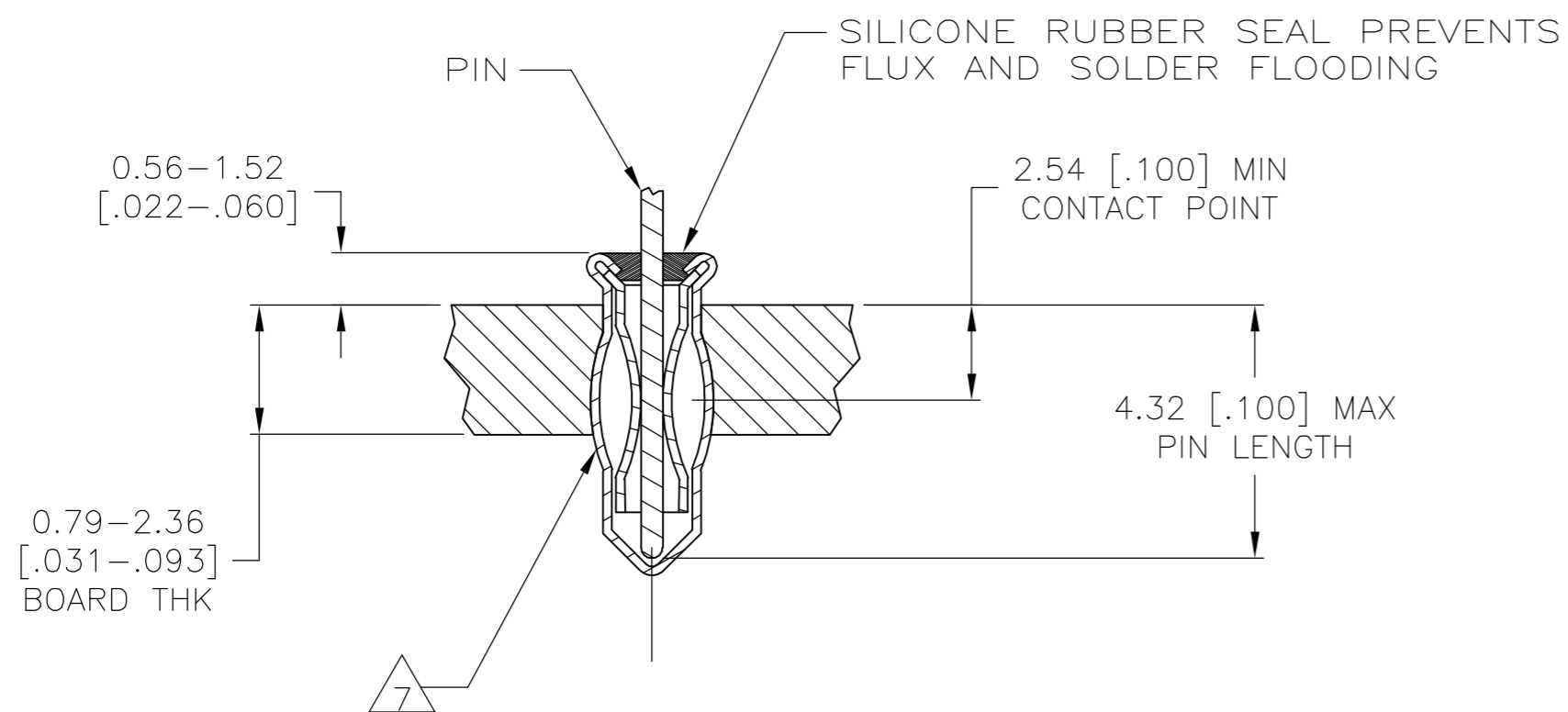
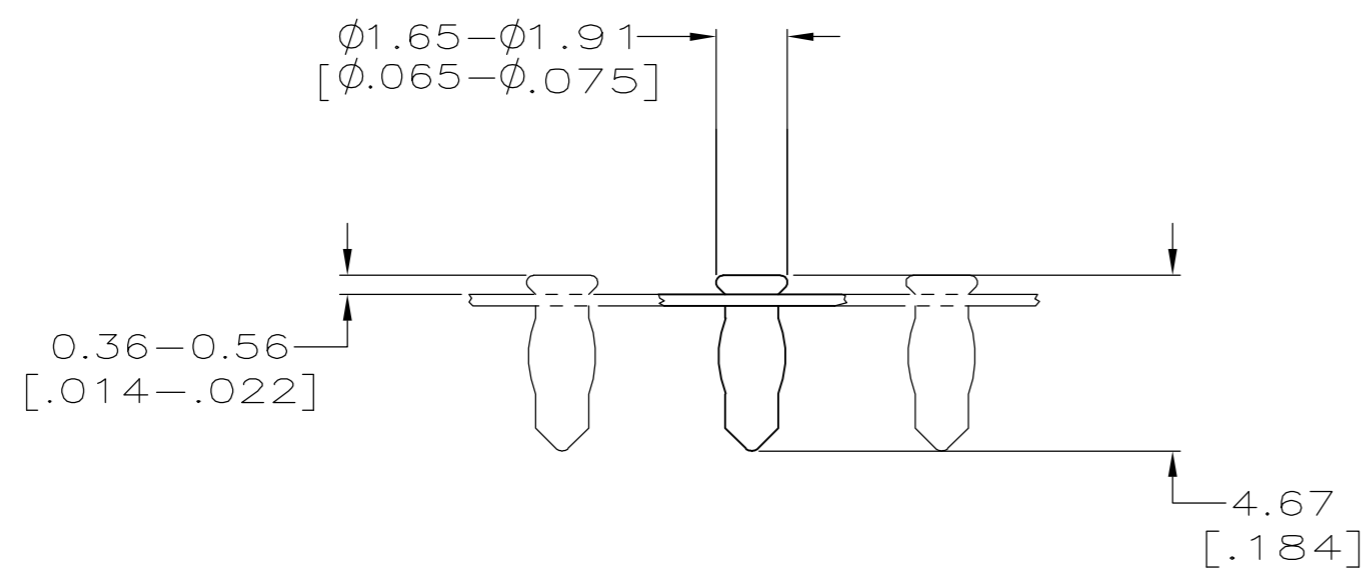
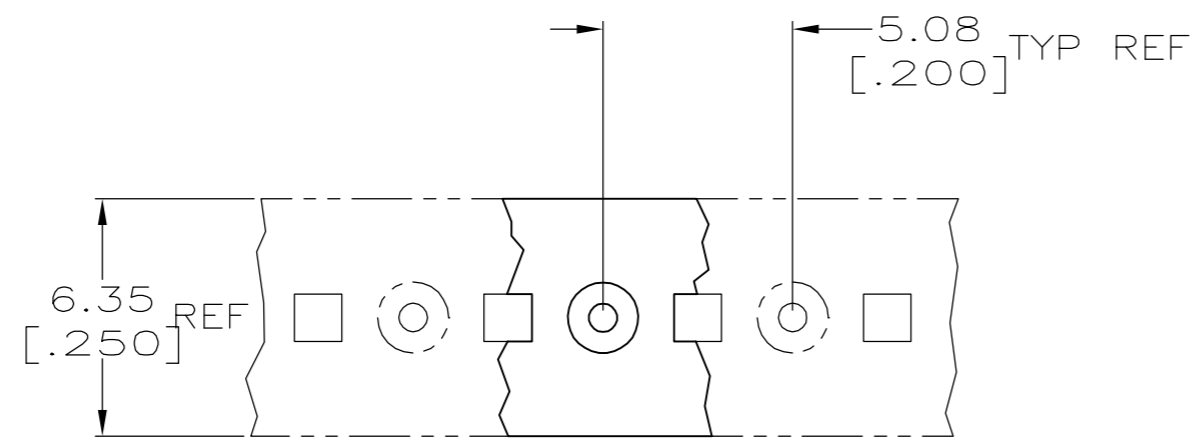

- 1 MATERIAL:  
EYELET - COPPER (QQ-C-576)  
SPRING - BERYLLIUM COPPER (QQ-C-533)  
SEALANT - SILICONE RUBBER
- 2 TIN PLATE (MIL-T-10727)0.00381 [.000150] MIN THK.
- 3 TIN PLATE(MIL-T-10727)0.00254 [.000100] MIN THK.
- 4 GOLD PL(MIL-G-45204)0.00076 [.000030] MIN THK ON CONTACT AREA.
- 5 PACKAGED 50,000 PER REEL
- 6 TO INSURE 1/2 OZ MIN RETENTION DO NOT EXCEED 0.10 [.004] DIFFERENCE IN PIN DIA WHEN CHANGING TO A SMALLER DIA PIN
- 7 PRODUCT IS OVALIZED FOR RETENTION IN THE P.C. BOARD. THE RECOMMENDED HOLE DIAMETER IS  $\phi 1.32$  [ $\phi .052$ ] MINIMUM, +0.08 [.003] MAX. PRIOR TO SOLDERING.
- 8 TIN-LEAD PLATE 0.00381 [.000150] MIN THK.
- 9 PACKAGED 10,000 PER REEL

	2.54-4.32 [.100-.170]	$\phi 0.36-\phi 0.66$ [ $\phi .014-\phi .026$ ]	GOLD 4	TIN 2	9 1-645955-2
	2.54-4.32 [.100-.170]	$\phi 0.36-\phi 0.66$ [ $\phi .014-\phi .026$ ]	TIN 3	TIN 2	9 1-645955-1
	2.54-4.32 [.100-.170]	$\phi 0.36-\phi 0.66$ [ $\phi .014-\phi .026$ ]	GOLD 4	TIN 8	5 645955-3
OBSOLETE	2.54-4.32 [.100-.170]	$\phi 0.36-\phi 0.66$ [ $\phi .014-\phi .026$ ]	GOLD 4	TIN 2	5 645955-2
OBSOLETE	2.54-4.32 [.100-.170]	$\phi 0.36-\phi 0.66$ [ $\phi .014-\phi .026$ ]	TIN 3	TIN 2	5 645955-1
	LENGTH	DIA 6	SPRING	EYELET	PART NO.

THIS DRAWING IS A CONTROLLED DOCUMENT.		DWN M.BOWERS 12-20-82	Tyco Electronics Corporation Harrisburg, Pa 17105-3608		
DIMENSIONS: mm [INCHES]		CHK P.MUTZABAUGH 6-10-85			
TOLERANCES UNLESS OTHERWISE SPECIFIED:		APVD G.D. MILLER 6-10-85	NAME		
0 PLC ± -		PRODUCT SPEC	MINIATURE SPRING SOCKET ASSY		
1 PLC ± -		APPLICATION SPEC	SERIES 2 LONG		
2 PLC ± -		114-26004	WITH SEALANT		
3 PLC ± 0.20[.008]		WEIGHT -	SIZE A2	CAGE CODE 00779	DRAWING NO C=645955
4 PLC ± -		CUSTOMER DRAWING	SCALE NONE	SHEET 1 OF 1	REV K1
ANGLES ± -					
FINISH SEE TABLE					