

- ① HOUSING MATERIAL: GLASS-FILLED POLYMER.
- ② CONTACT MATERIAL: COPPER ALLOY.
- ③ CONTACT FINISH: DIN 41612 CLASS 2 IN CONTACT AREA. TIN PLATE ON POSTS.
- ④ PART NUMBER, DATE CODE IDENTIFICATION, CSA LOGO IN THIS APPROXIMATE AREA, ON REVERSE SIDE.
- ⑤ CONTACT POINT.
- ⑥ ACTION PIN POSTS REQUIRE 1.57[.062] MINIMUM THICK PC BOARD. RECOMMENDED PC BOARD HOLES ARE $\phi 1.51 \pm 0.02$ [.0453 \pm .001] DRILLED HOLES WITH 0.02-0.08 [.001-.003] COPPER AND 0.008 [.0003] MINIMUM TIN-LEAD PLATING. FINISHED HOLES AFTER PLATING, $\phi 0.94-1.09$ [.037-.043].

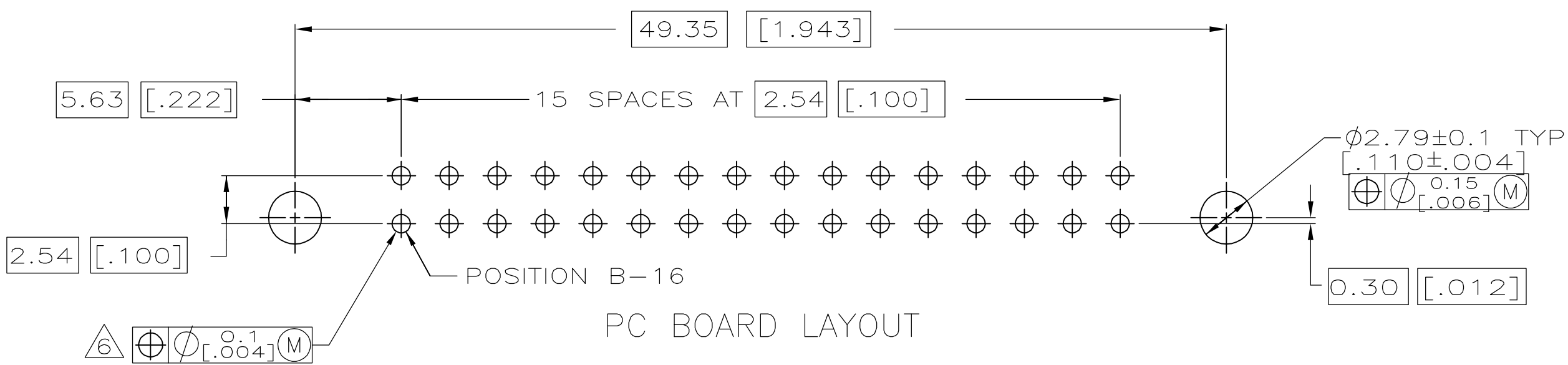
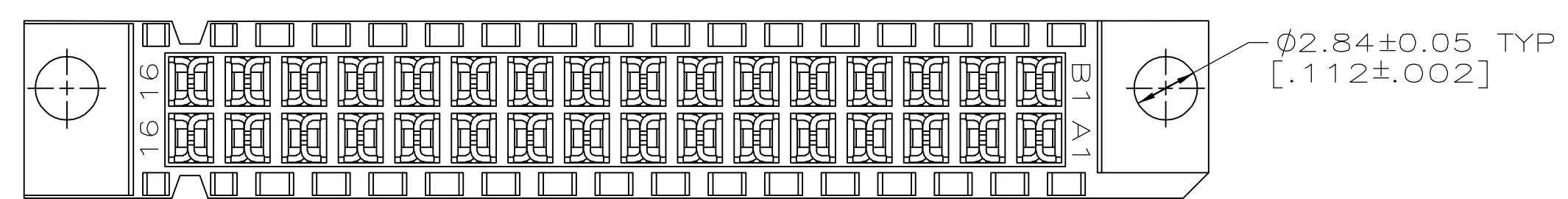
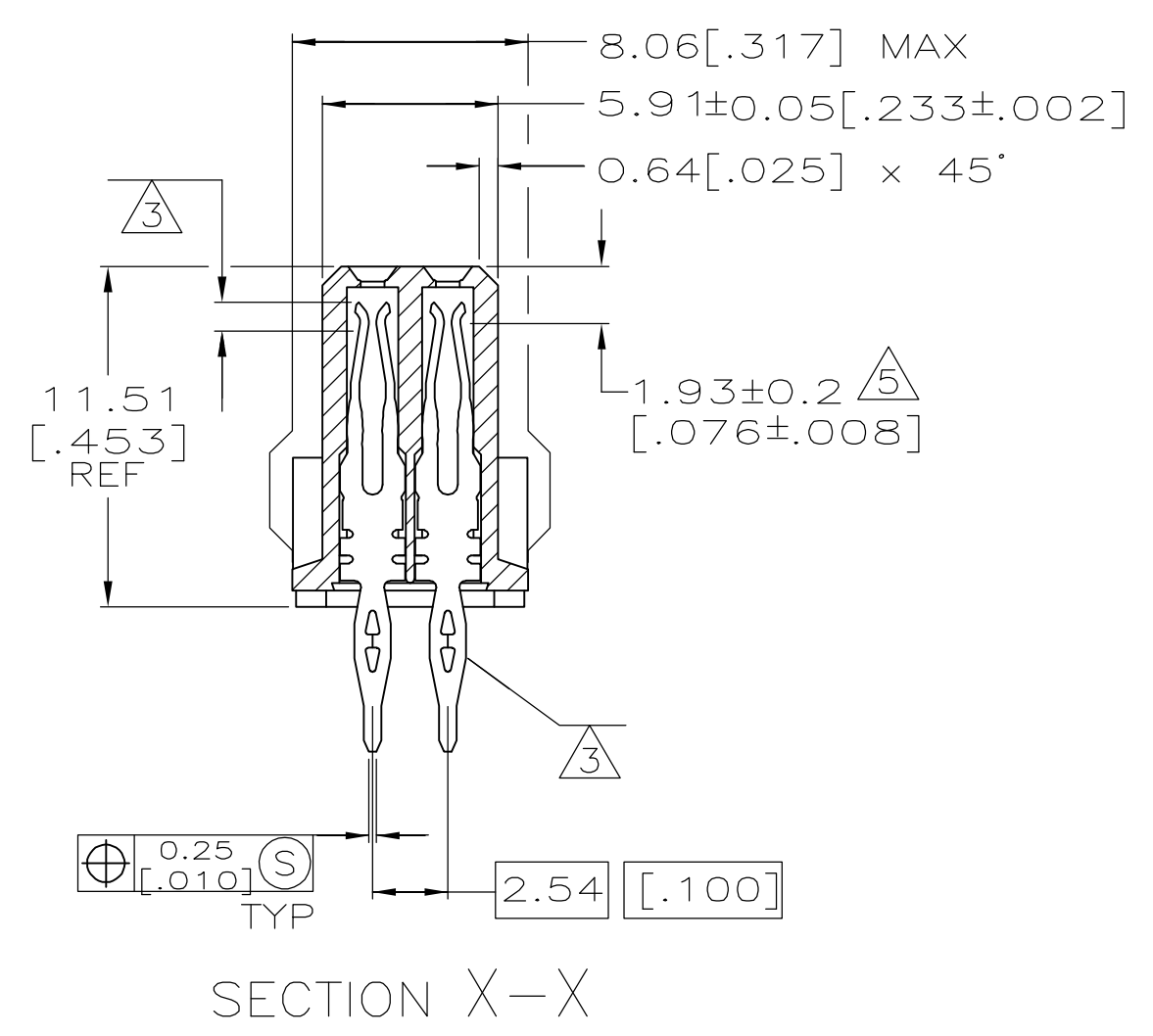
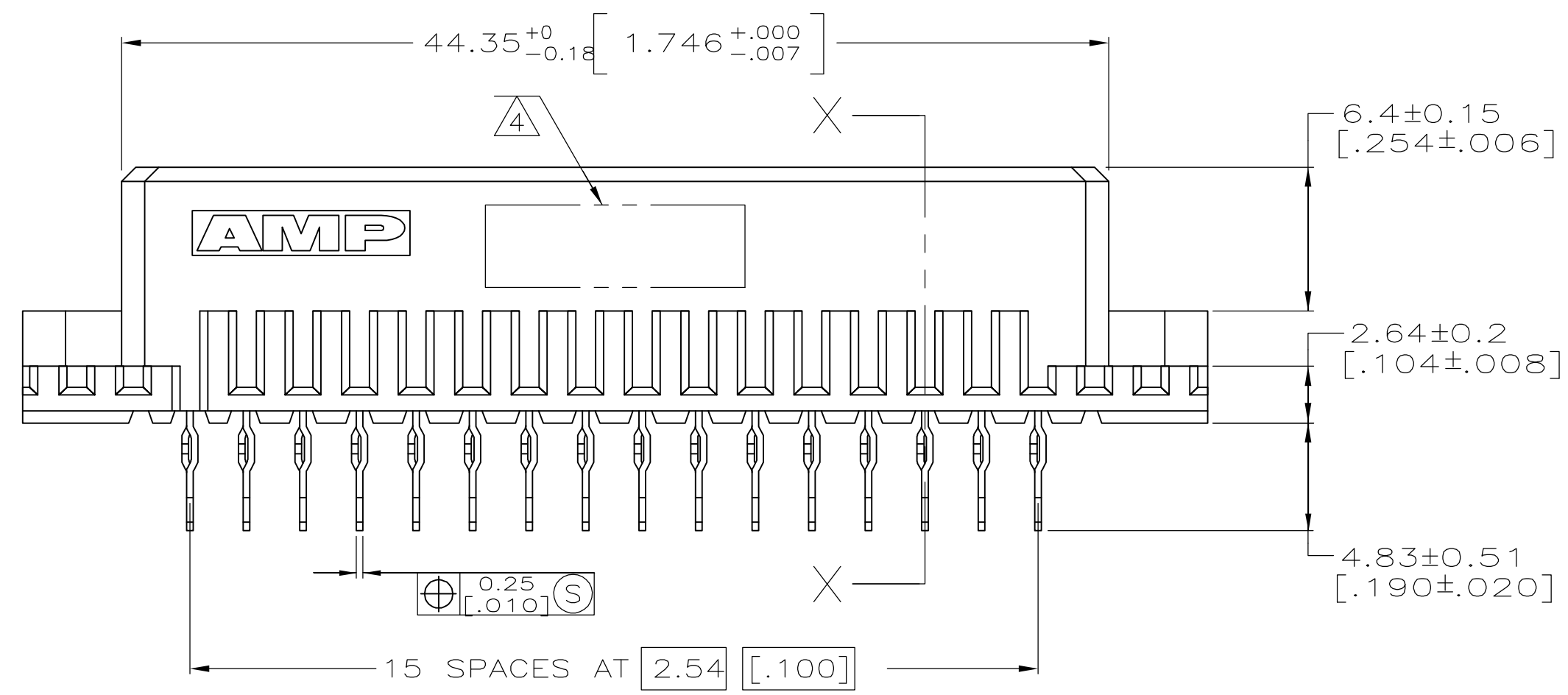
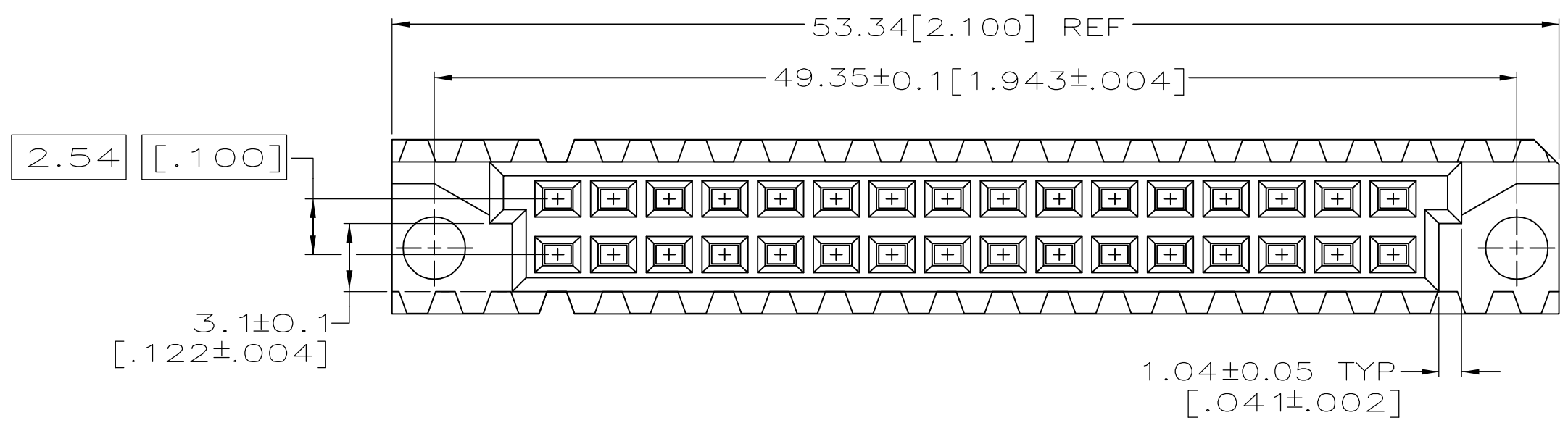

5650864-5
 ASSY PART NUMBER

THIS DRAWING IS A CONTROLLED DOCUMENT.		DIN J. POLIGNONE 03JUN05		Tyco Electronics Corporation Harrisburg, PA 17105-3608	
DIMENSIONS: mm [INCHES]		CHK A. SHARPE 03JUN05		APVD A. SHARPE 03JUN05	NAME ASSEMBLY, RECEPTACLE, EUROCARD, TYPE B, 32 POSITION, 4.83[.190], TOOLLESS, PRESS-FIT
TOLERANCES UNLESS OTHERWISE SPECIFIED:		0 PLC ± - 1 PLC ± - 2 PLC ± - 3 PLC ± 0.13[.005] 4 PLC ± - ANGLES ± -		APPLICATION SPEC	SIZE A1
MATERIAL		FINISH		WEIGHT	CAGE CODE DRAWING NO. 00779 C=5650864
		CUSTOMER DRAWING		SCALE 4:1	SHEET 1 OF 1 REV 0