

DESCRIPTION

The EV2603EJ-00B is an evaluation board for the MP2603, a low cost single cell Li-ion battery charger IC suitable for low charge current applications.

The MP2603 features constant current (CC) and constant voltage (CV) charging modes with programmable charge current (50mA–150mA), trickle charge and charge status indication.

The MP2603 is enabled with an input supply voltage greater than 3.5V. The charger IC is disabled when unplugged from the AC adaptor. To minimize the charger's total solution cost, the MP2603 does not need an external reverse blocking diode, a precision current-sense resistor or a compensation capacitor at the output. The MP2603 is available in a 5-pin TSOT23 package.

ELECTRICAL SPECIFICATIONS

Parameter	Symbol	Value	Units
Input Voltage	V_{IN}	5	V
Output Voltage	V_{OUT}	4.2	V

FEATURES

- 0.75% V_{BATT} Accuracy
- Low Battery Reverse Current ($< 1\mu A$)
- Charge Status Indication
- No External Sense Resistor
- No External Reverse Blocking Diode
- Fully Assembled and Tested

APPLICATIONS

- Bluetooth Headsets
- MP3 Players
- Mini PDAs
- Cell Phones
- Digital Cameras

"MPS" and "The Future of Analog IC Technology" are Registered Trademarks of Monolithic Power Systems, Inc.

EV2603EJ-00B EVALUATION BOARD

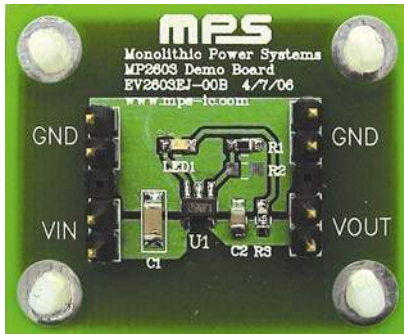

(L x W x H) 1.4" x 1.1" x 0.5"
(3.5cm x 2.8cm x 1.0cm)

Board Number	MPS IC Number
EV2603EJ-00B	MP2603EJ

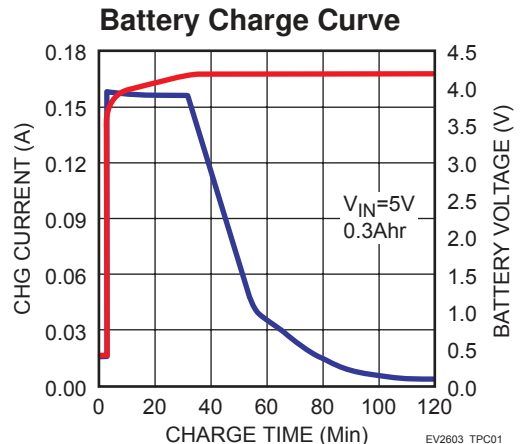

EVALUATION BOARD SCHEMATIC

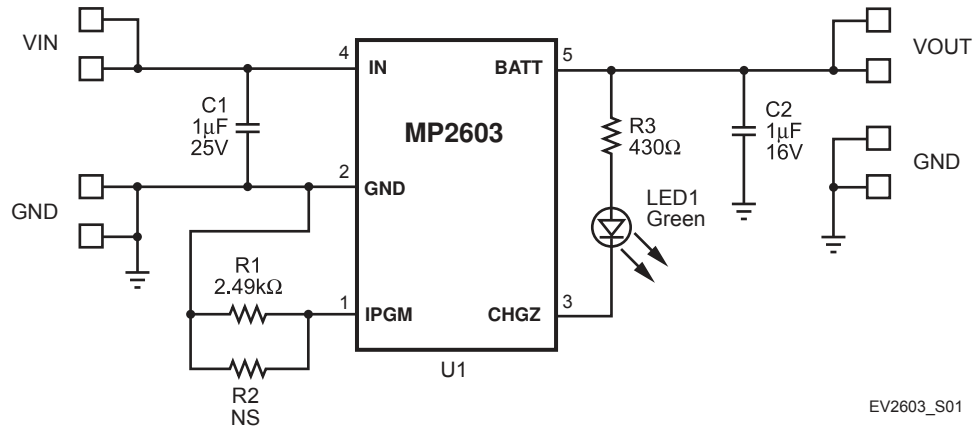

EV2603EJ-00B BILL OF MATERIALS

Qty	Ref	Value	Description	Package	Manufacturer P/N
1	C1	1µF	Ceramic Capacitor, 25V, X7R	1206	TDK: C3216X7R1E105K
1	C2	1µF	Ceramic Capacitor, 16V, X7R	0805	TDK: C2012X7R1C105K
1	LED1		Led, Green, Surface Mount	0603	Lumex: SML-LX0603GW-TR
1	R1	2.49kΩ	Resistor, 1%	0603	Panasonic: ERJ-3EKF2492V
1	R2		Do Not Stuff		
1	R3	430Ω	Resistor, 5%	0603	Panasonic: ERJ-3GEYJ431V
1	U1		Single-Cell Battery Charger	TSOT23-5	MPS: MP2603EJ

PRINTED CIRCUIT BOARD LAYOUT

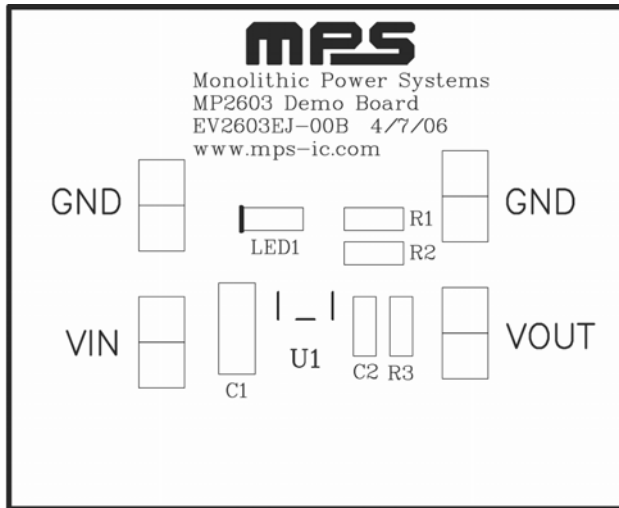

Figure 1—Top Silk Layer

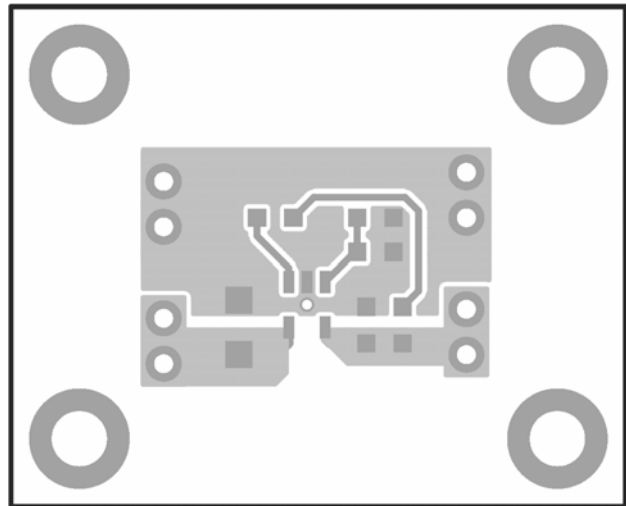

Figure 2—Top Layer

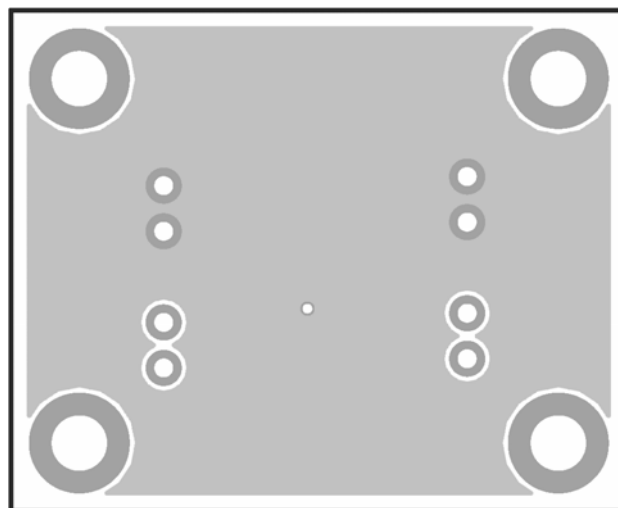

Figure 3—Bottom Layer

QUICK START GUIDE

The output voltage on this board is set for a single cell battery at 4.2V. The board layout accommodates most commonly used capacitors

1. Setup the charge current, I_{CHG} , by adjusting the value of R1. This is done using the following equation:

$$I_{CHG} = 150\text{mA} \times \frac{2.5\text{k}\Omega}{R1}$$

2. Attach the positive and negative ends of the VOUT and GND pins, respectively.
3. Attach the input voltage ($V_{IN} = 5\text{V}$) and the input ground to the VIN and GND pins, respectively.
4. Note the LED indicator. When the LED is on, the battery is charging. When the battery is fully charged or there is no battery present, the LED will be off.