

4

3

2

1

THIS DRAWING IS UNPUBLISHED. RELEASED FOR PUBLICATION 20

COPYRIGHT 20 BY - ALL RIGHTS RESERVED.

LOC	DIST	REVISIONS					
AA	00	P	LTR	DESCRIPTION	DATE	DWN	APVD
		B		ECO-08-004426	22APR2008	TR	TX
		C		ECO-10-019861	30SEP2010	RZ	KZ
		D		REVISED PER ECO-11-025480	09APR2012	TY	KZ
		E		REVISED PER ECO-12-007988	26APR2012	TY	KZ

1. MATERIALS

HOUSING: THERMOPLASTIC, BLACK, FLAMMABILITY RATED UL 94V-0

SHIELD: BRASS, 0.20mm THICK,

PREPLATED WITH MIN 0.76um SEMI-BRIGHT NICKEL

POST DIPPED WITH 2.54um MIN SAC SOLDER AT GROUND PINS.

CONTACTS: PHOSPHOR BRONZE, PLATED WITH 1.27um MIN OVERALL NICKEL UNDERPLATE,

SELECTIVE 1.27um MIN GOLD AT MATING INTERFACE AND 2.54um MIN MATTE

TIN ON SOLDER TAILS. OR 1.27um MIN NICKEL UNDERPLATE, WITH 0.05um

GOLD PLATING OVER 0.76um MIN PALLADIUM NICKEL PLATING AT MATING

INTERFACE AND 2.54um MIN MATTE TIN ON SOLDER TAILS.

SOLDER TAIL: PHOSPHOR BRONZE,

WITH 1.27um MIN OVERALL NICKEL UNDERPLATE AND

PLATED WITH 2.54um MIN TIN

LED: DIFFUSED EPOXY LENS, 0.50mm SQUARE CARBON STEEL WIREFRAME LEADS

PREPLATED WITH 2.03um MIN SILVER OVER 1.02um MIN NICKEL

OVER 1.02um MIN COPPER UNDERPLATE POST PLATED WITH 2.54um MIN TIN

2. MAGNETICS

-APPLICATION: 10/100 BASE-T

-IMPEDANCE: 100 OHMS

-TURNS RATIO (CHIP:CABLE): TX = 1:1, RX = 1:1

-OPEN CIRCUIT INDUCTANCE (OCL): 350uH MIN @100kHz, 0.1VRMS,

8mADC BIAS FROM 0°C TO 70°C, TX AND RX

-PERFORMANCE @ 25°C:

INSERTION LOSS (IL): 1.1dB MAX FROM 0.5MHz TO 100MHz

RETURN LOSS (RL): 18dB MIN FROM 0.5MHz TO 30MHz

18-20LOG(f/30)dB MIN FROM 30.1MHz TO 60MHz

12dB MIN FROM 60.1MHz TO 80MHz

CROSSTALK ATTENUATION: 35dB MIN FROM 0.5MHz TO 40MHz

33-20LOG(f/50)dB MIN FROM 40.1MHz TO 100MHz

COMMON MODE REJECTION RATIO (CMRR): 30dB MIN FROM 0.5MHz TO 100MHz

-ISOLATION VOLTAGE: COMPLIES WITH IEEE802.3 2002, PARA 23.5.1.1, ITEM b.

3. THE MAGNETIC ARE SYMMETRICAL AND SUPPORT AUTO-MDIX OPERATION.

4. OPERATING TEMPERATURE: 0 - 70°C

5. LED IS DRIVEN WITH CONSTANT CURRENT AT APPROX 20mA.

DOMINANT WAVELENGTH(λ D)

GREEN 568nm TYP.at IF=20mA

YELLOW 588nm TYP.at IF=20mA

FORWARD VOLTAGE(VF):

GREEN 2.2V TYP.at IF=20mA

YELLOW 2.1V TYP.at IF=20mA

6. ALL DIMENSIONS TO BE NOMINAL UNLESS OTHERWISE NOTED

7. RJ45 CAVITY CONFORMS TO FCC RULES AND REGULATION PART 68 SUBPART F.

YES	YELLOW	GREEN	1-1840419-3
NO	GRN/YEL	GRN/YEL	1840419-4
NO	YELLOW	GREEN	1840419-3
NO	GREEN	YELLOW	1840419-2
NO	GREEN	GREEN	1840419-1
CUT OUT	LED 1	LED 2	PART NUMBER

THIS DRAWING IS A CONTROLLED DOCUMENT.		DWN	TOMMY REN	18AUG2006	 TE Connectivity				
DIMENSIONS:		CHK	KEITH ZHU	18AUG2006					
mm		APVD	TEDDY XIONG	18AUG2006					
TOLERANCES UNLESS OTHERWISE SPECIFIED:		NAME	1X1 MAG45(TM) MODULAR JACK, VERTICAL TYPE, 426P13 CIRCUIT WITH LED						
0 PLC	±0.25	PRODUCT SPEC	108-2100						
1 PLC	±0.25	APPLICATION SPEC							
2 PLC	±0.25	SIZE	A2	00779	CAGE CODE	1840419	DRAWING NO	RESTRICTED TO	
3 PLC	±0.25	WEIGHT			SCALE	1.000	SHEET	1 OF 2	
4 PLC	±	CUSTOMER DRAWING			REV	E			
ANGLES	±								
FINISH	±								

1471-9 (3/11)

LOC	DIST	REVISIONS					
AA	00	P	LTR	DESCRIPTION	DATE	DWN	APVD
		-		SEE SHEET 1			

426P13 10/100 BASE-T CIRCUIT Δ Δ

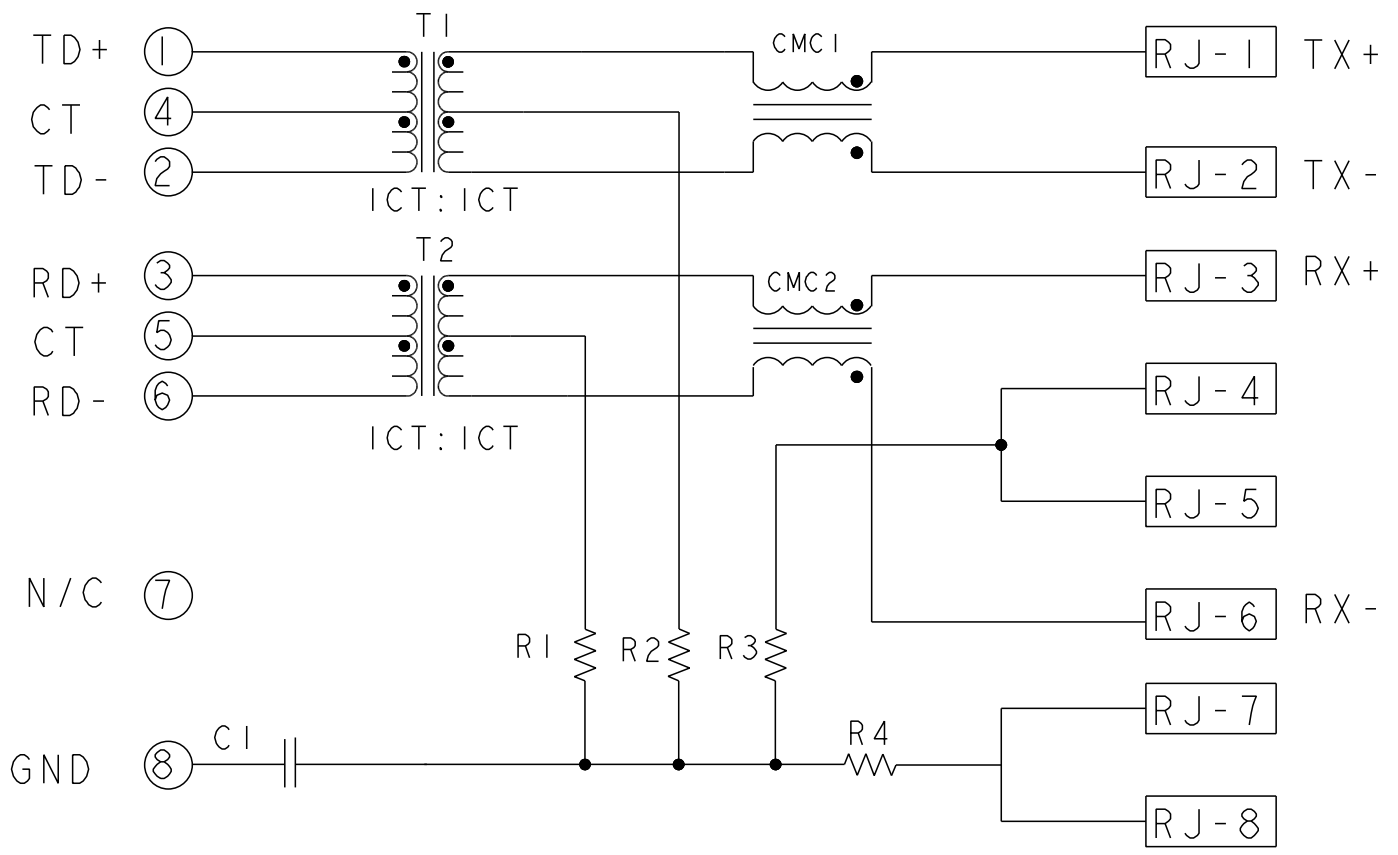

C1 = 1000pF, 2KV, CAPACITOR
 R1 - R4 = 75 ohms, RESISTOR

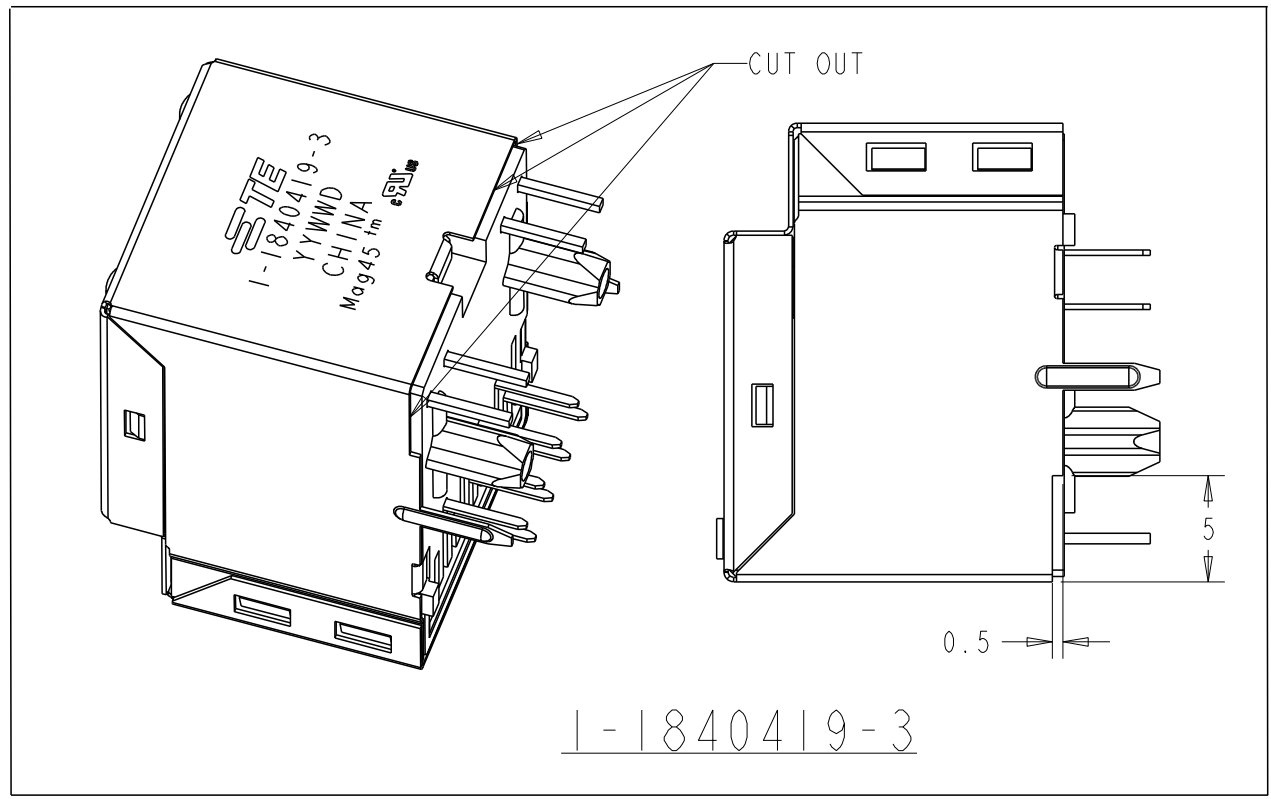
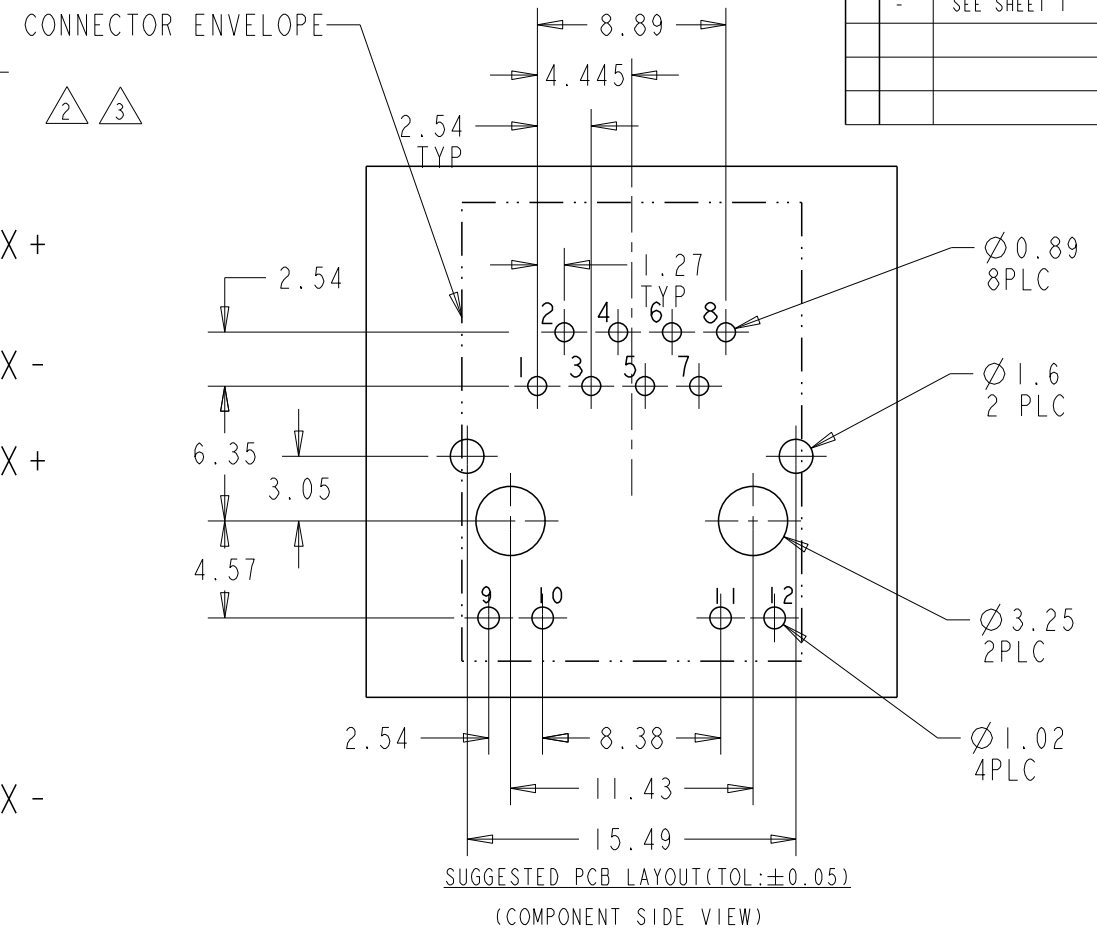
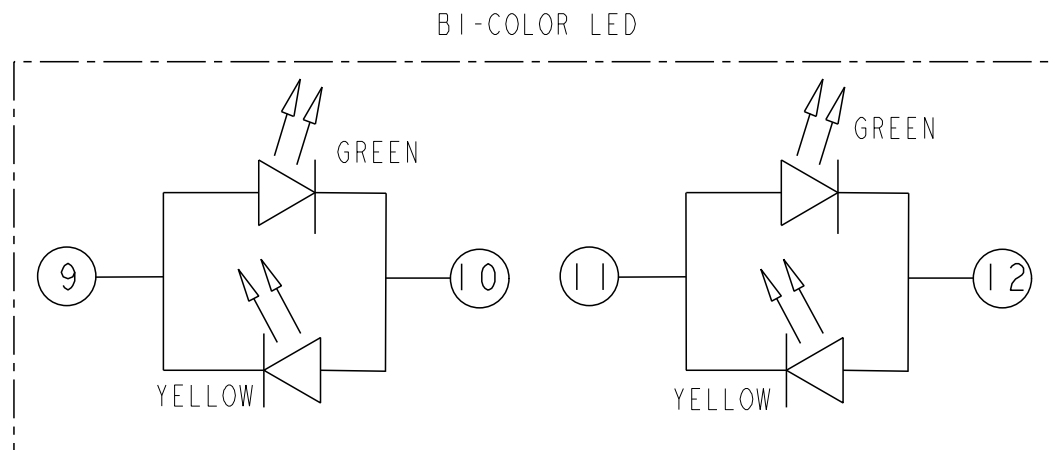
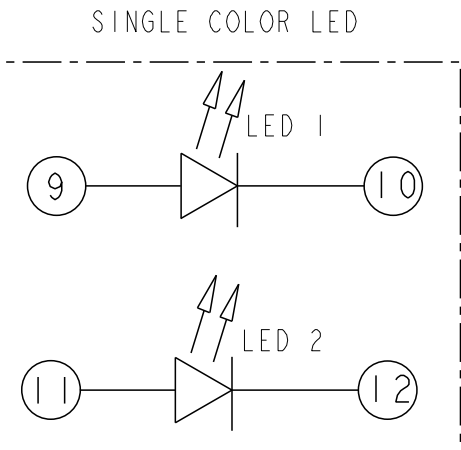

THIS DRAWING IS A CONTROLLED DOCUMENT.		DWN TOMMY REN 18AUG2006	TE Connectivity	
		CHK KEITH ZHU 18AUG2006		
		APVD TEDDY XIONG 18AUG2006	NAME 1X1 MAG45(TM) MODULAR JACK, VERTICAL TYPE, 426P13 CIRCUIT WITH LED	
DIMENSIONS: mm		TOLERANCES UNLESS OTHERWISE SPECIFIED:	PRODUCT SPEC 108-2100	
		0 PLC ±0.25	APPLICATION SPEC	
		1 PLC ±0.25	SIZE A2	
		2 PLC ±0.25	CAGE CODE 00779	
		3 PLC ±0.25	DRAWING NO C=1840419	
		4 PLC ±	RESTRICTED TO	
MATERIAL		FINISH	WEIGHT	
			CUSTOMER DRAWING	
			SCALE 4.000 SHEET 2 OF 2 REV E	