

# MON





We fast forward  
the evolution of  
new products.

---

# Table of Contents

---

<b>1</b>	<b>Introduction</b>	<b>4</b>
1.1	Development Platform Contents	4
<b>2</b>	<b>Feature Diagrams</b>	<b>5</b>
<b>3</b>	<b>Setup</b>	<b>9</b>
3.1	Connecting the Debug Board	9
3.2	Getting to a U-Boot Prompt	9
3.3	Connecting the Battery	10
3.4	Charging the Battery	11
<b>4</b>	<b>Product Notices</b>	<b>12</b>
<b>5</b>	<b>Support Resources</b>	<b>13</b>
5.1	Register your Development Platform	13
5.2	Hardware Documentation	13
5.3	Software Resources	14
5.4	Warranty Statement	14
<b>6</b>	<b>Revision History</b>	<b>15</b>

# Table of Figures

---

Figure 2.1 –Handheld Features (Front)	5
Figure 2.2 –Handheld Features (Bottom)	6
Figure 2.3 –Handheld Features (Side)	6
Figure 2.4 –Handheld Features (Back / Covers Removed)	7
Figure 2.5 –Debug Board Features	8
Figure 3.1 –Connect Power Supply and Adapter	9
Figure 3.2 –Battery Connector Location	11

# 1 Introduction

---

Congratulations on your purchase of the Zoom™ OMAP36x Mobile Development Platform (MDP). The Zoom OMAP36x MDP addresses essential needs of the open-source community and high-level operating system (HLOS) developers to speed software development for smartphones and Mobile Internet Devices (MIDs).

## 1.1 Development Platform Contents

The Zoom OMAP36x MDP includes the following items:

- +Handheld
  - +Integrated SOM-LV featuring Texas Instruments' OMAP3630 processor
  - +4.1" WVGA LCD
  - +QWERTY keypad
- +Debug board
- +Power supply with US, UK, Japan, and Europe power adapters
- +USB A-to-Mini-B cable
- +QuickStart Guide

# 2 Feature Diagrams

Figure 2.1 – Handheld Features (Front)

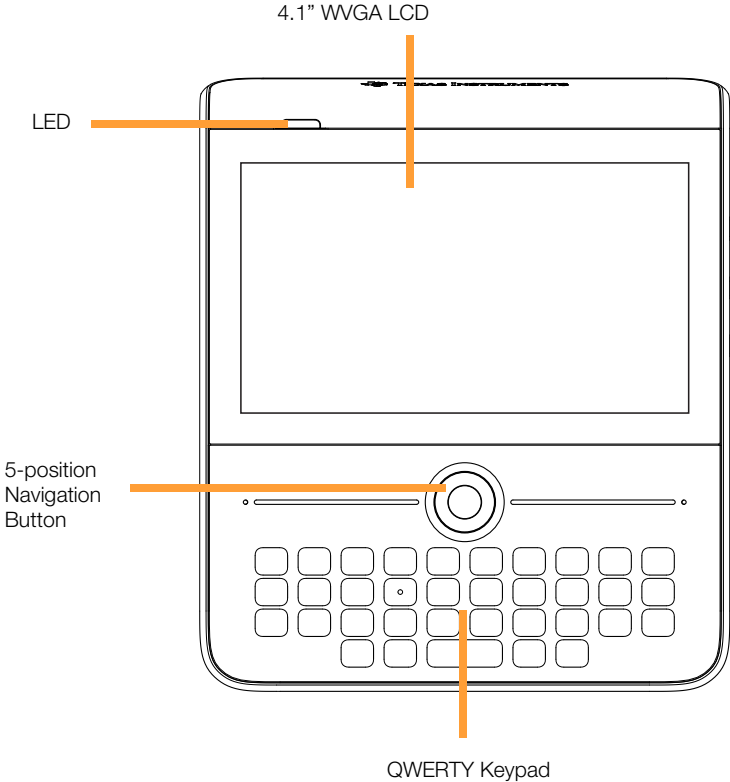

**Figure 2.2 – Handheld Features (Bottom)**

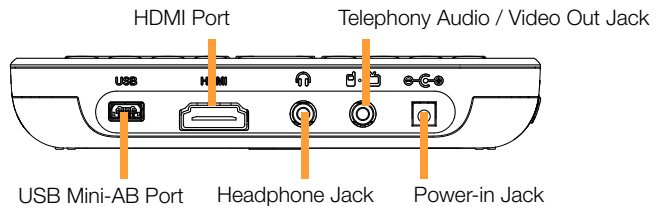

**Figure 2.3 – Handheld Features (Side)**

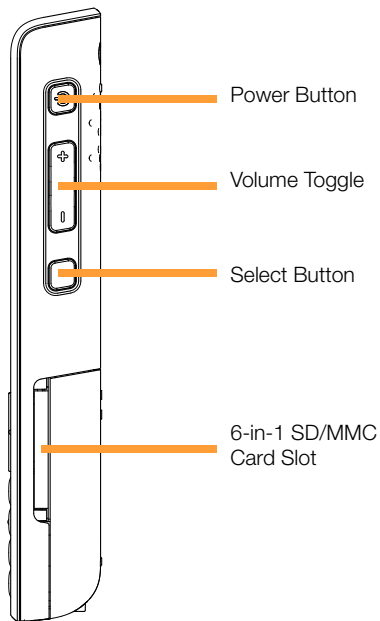



Figure 2.4 – Handheld Features (Back / Covers Removed)

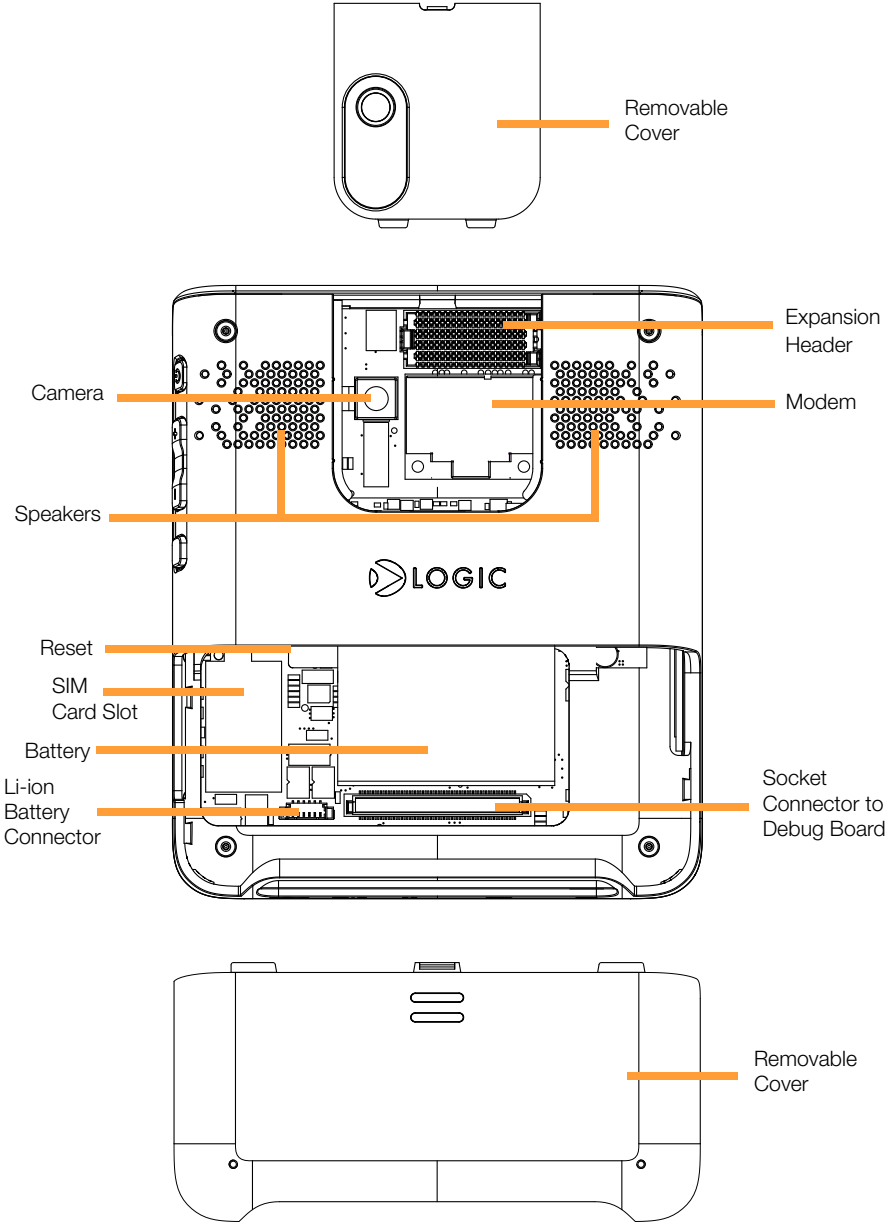
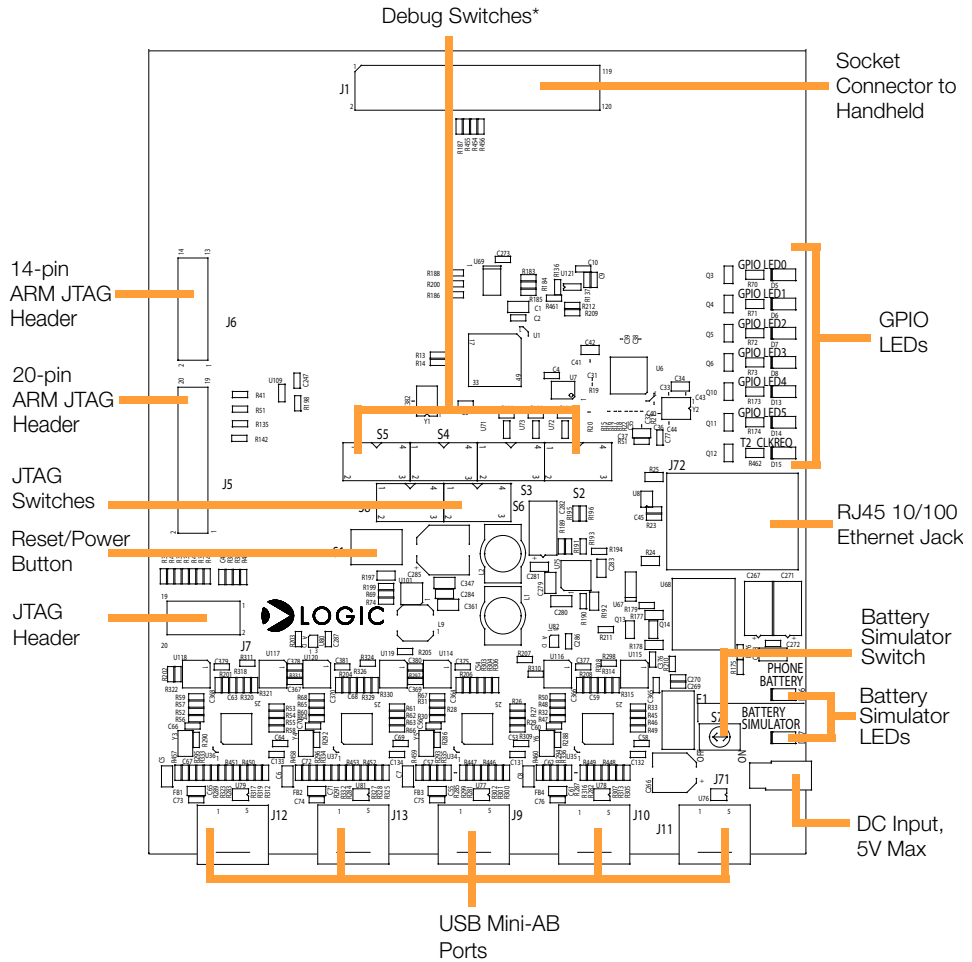

Figure 2.5 – Debug Board Features



\*NOTE: Information about debug switch settings is silkscreened on the bottom of the debug board and can also be found in the debug board schematics.

## 3 Setup

### 3.1 Connecting the Debug Board

To connect the debug board to the handheld:

1. Remove the bottom cover on the back of the handheld.
2. Align the keyed socket connector with the mating connector on the debug board (see Figure 2.4 and Figure 2.5 for connector locations).
3. Press down over the connectors.
4. Verify the connectors have mated properly.

**IMPORTANT NOTE:** The DC Input jack on the debug board can be used to power the handheld and the debug board for general use. However, using the DC Input jack on the debug board will not charge the handheld battery. Never have more than one power supply connected to the Zoom OMAP36x MDP at any given moment.

### 3.2 Getting to a U-Boot Prompt

1. Verify the debug board is connected to the handheld.
2. Make sure the power switch (S7) on the debug board is in the “OFF” position.
3. Connect the regulated 5V power supply to the appropriate power adapter for the region in which you are using the development platform.

**Figure 3.1 – Connect Power Supply and Adapter**



4. Plug the power adapter into an electrical outlet and the 5V line to the DC input connector on the debug board.

**NOTE:** Detailed instructions for Steps 5–10 can be found in a readme available on Logic’s website (<http://support.logicpd.com/downloads/1206/>). Please refer to the readme if you encounter any difficulty with the following steps.

5. Download the FT2232 VCP driver from the FTDI website [www.ftdichip.com/Drivers/VCP.htm](http://www.ftdichip.com/Drivers/VCP.htm)
6. Connect the included USB cable to the USB mini-AB connector labeled J12 on the debug board and to a USB port on your development PC.
7. Windows should recognize your new hardware.
8. Open the Device Manager on your computer to determine what COM port number was assigned to the USB-to-Serial connection.
9. Launch your terminal emulation program. (Although Logic does not support any particular terminal emulation program, we suggest using Tera Term Pro for Windows 2000 or XP, which can be downloaded from Logic’s website at: <http://support.logicpd.com/downloads/240/> ).
10. Open a new serial port connection in your terminal emulation program with the following settings:
  - +Port: COM port number found in Step 8 above
  - +Baud rate: 115200
  - +Data: 8-bit
  - +Parity: none
  - +Stop: 1-bit
  - +Flow control: none
11. Move the power switch (S7) on the debug board to the “ON” position. The handheld LED should display a blue light and then a red light. After the red light displays, a U-Boot prompt should appear in your terminal emulation program.
12. You are now able to communicate with your handheld.
13. Instructions for next steps or software updates and installs are available at <http://www.omapzoom.org>

### 3.3 Connecting the Battery

The handheld comes with an 1100 mAh Li-ion battery installed, but not connected. Follow the steps below to connect the battery.

1. With the back of the handheld facing you, remove the bottom cover and locate the Li-ion battery connector on the baseboard PCB (see Figure 3.2).

Figure 3.2 – Battery Connector Location

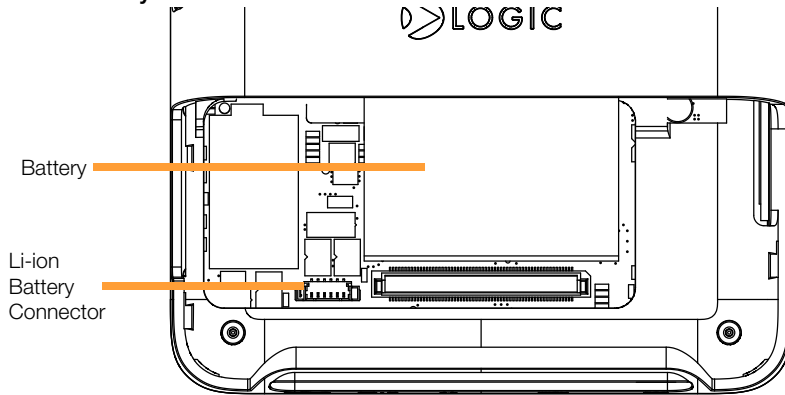

2. Align the end of the battery cable over the connector and make sure the side-tabs of the connectors align properly.
3. Fully insert the connector.

### 3.4 Charging the Battery

The power supply included with the Zoom OMAP36x MDP can be used to charge the battery.

1. Connect the regulated 5V power supply to the appropriate power adapter for the region in which you are using the development platform.
2. Plug the power adapter into an electrical outlet and the 5V line output connector into the power-in jack on the bottom of the handheld (see Figure 2.2 for power-in jack location).

**IMPORTANT NOTE:** To charge the battery, update the U-Boot or X-Loader software to the latest version available from <http://www.omapzoom.org>. Once the software has been updated, you must connect the power supply to the power-in jack on the bottom of the handheld to charge the battery; plugging the power supply into the debug board will not charge the battery.

## 4 Product Notices

---

This development kit is intended for use for **ENGINEERING DEVELOPMENT, DEMONSTRATION, OR EVALUATION PURPOSES ONLY** and is not considered by TI and Logic to be a finished end-product fit for general consumer use. Persons handling the product(s) must have electronics training and observe good engineering practice standards. As such, the goods being provided are not intended to be complete in terms of required design-, marketing-, and/or manufacturing-related protective considerations, including product safety and environmental measures typically found in end products that incorporate such semiconductor components or circuit boards. This development kit does not fall within the scope of the European Union directives regarding electromagnetic compatibility, recycling (WEEE), FCC, CE or UL, and therefore may not meet the technical requirements of these directives or other related directives.

### ESD

The user assumes all responsibility and liability for proper and safe handling of the goods. Further, the user indemnifies TI and Logic from all claims arising from the handling or use of the goods. Due to the open construction of the product, it is the user's responsibility to take any and all appropriate precautions with regard to electrostatic discharge.

### FCC Warning

This development kit is intended for use for **ENGINEERING DEVELOPMENT, DEMONSTRATION, OR EVALUATION PURPOSES ONLY** and is not considered by TI and Logic to be a finished end-product fit for general consumer use. It generates, uses, and can radiate radio frequency energy and has not been tested for compliance with the limits of computing devices pursuant to part 15 of FCC rules, which are designed to provide reasonable protection against radio frequency interference. Operation of this equipment in other environments may cause interference with radio communications, in which case the user at his own expense will be required to take whatever measures may be required to correct this interference.

## 5 Support Resources

### 5.1 Register your Development Platform

Registration provides you access to the latest revision of this manual, as well as other documentation. In addition to downloads access, registration provides future notifications when Logic releases documentation updates for your product.

1. To register, visit the Logic Support website at [www.logicpd.com/product-support](http://www.logicpd.com/product-support) and click on “Create Account”.
2. Fill in the on-screen form and click the “Submit” button.
3. You will receive an e-mail with a URL link to confirm account creation. Click on the link to finalize account creation.
4. You will be directed to a page on Logic’s website that states “Account Activated”. At this point you can register your product. Click on the link to “register your development kit and get access to downloads”.
5. Fill in the on-screen form (all fields are required) and click the “Submit” button.
6. Your product is now registered. Click on the “Return to your Account Overview” link and you will see the list of registered products for your account.

Under the heading for “OMAP36x Zoom Mobile Development Platform”, click the “All Downloads” link to access the downloads associated with your Zoom OMAP36x MDP.

### 5.2 Hardware Documentation

Logic provides additional documentation resources for the Zoom OMAP36x MDP. These additional resources are available as downloads from the “My Account” section of the Logic website. Click on the “Log In” link at the top of any [www.logicpd.com](http://www.logicpd.com) web page and enter your username and password to access the downloads available for your product.

Additional documentation includes:

- +Handheld Schematics, Layout Files, & BOM
- +Debug Board Schematics, Layout Files, & BOM
- +*Zoom OMAP36x MDP QuickStart Guide*
- +White Papers, Application Notes, and Product Change Notifications (PCNs) as they become available

## 5.3 Software Resources

For information on the Zoom OMAP36x MDP software community, please visit:  
<http://www.omapzoom.org>

## 5.4 Warranty Statement

Please refer to the “Important Notice” enclosed with the Zoom OMAP36x MDP for warranty statements, RMA information, and other important notifications.



## 6 Revision History

---

REV	EDITOR	REVISION DESCRIPTION	APPROVAL	DATE
A PN 1013915	JCA	Initial Release	RK	02/22/10

Please check [www.logicpd.com](http://www.logicpd.com) for the latest revision of this manual and other documentation.

OMAP is a registered trademark of Texas Instruments Incorporated.

This page intentionally left blank.





## embedded product solutions

411 N. Washington Ave. Suite 400 Minneapolis, MN 55401

T : 612.672.9495 F : 612.672.9489 I : [www.logicpd.com](http://www.logicpd.com)

Logic Product Development makes no warranty for the use of its products. The Company assumes no responsibility for any errors which may appear in this document, reserves the right to change devices or specifications detailed herein at any time without notice, and does not make any commitment to update the information contained herein. The names of the sample source code files and the platform dependent environment variables may be subject to change without notice. Some steps and figures may vary between different versions of tools. No licenses to patents or other intellectual property of Logic are granted by the company in connection with the sale of Logic products, expressly or by implication.

All rights reserved. Logic Product Development. Intel, Renesas, and Sharp are registered trademarks. Pentium is a registered trademark of Intel. Windows is a registered trademark of Microsoft Corporation. Zoom and LogicLoader are trademarks of Logic Product Development. Terms and product names in this document may be trademarks of others.