



The Future of Analog IC Technology®

EV3312-C-00A

Dual-Channel White LED Driver Evaluation Board

DESCRIPTION

The MP3312 is a dual-channel step-up WLED driver with integrated 40V MOSFET, and supports 2.7V to 5.5V power supply input. It uses peak current mode to regulate the LED current which is set by external resistor.

The MP3312 employs 1.2MHz fixed switching frequency. It features supporting both PWM input analog dimming and digital analog dimming to accurately regulate the dimming current.

The MP3312 integrates current source to balance LED current, which leads good ILED matching and accuracy performance.

In addition, the MP3312 has LED open and short protection, cycle by cycle current limit protection, and thermal shutdown protection. It is available in tiny WLCSP1.3X 1.3-9 package.

ELECTRICAL SPECIFICATIONS

Parameter	Symbol	Value	Units
Input Voltage	V_{IN}	2.7 – 5.5	V
Output Voltage	V_{LED}	<35	V
LED String		2	string
LED Current	I_{LED}	20/string	mA

FEATURES

- 2.7V~5.5V Input Voltage
- 1.2MHz Switching Frequency
- Dual Channels Support up to 30mA/String
- 1% Current Matching Between LED Channels
- +/-2% Current Accuracy
- 38V OVP Protection
- PWM Input Analog Dimming Mode
- 5kHz to 100kHz PWM Input Analog Dimming
- 100:1 Dimming Ratio
- 1-Wire Interface for Digital Dimming
- 9-bit Dimming Resolution
- Internal Soft Start to Reduce Inrush Current
- Available in WLCSP1.3X1.3-9 Package

APPLICATIONS

- Feature Phone and Smart Phones
- Tablets
- GPS Receivers
- <10 inch LCD video displays with one-cell Li-ion battery

All MPS parts are lead-free, halogen free, and adhere to the RoHS directive. For MPS green status, please visit MPS website under Quality Assurance. "MPS" and "The Future of Analog IC Technology" are Registered Trademarks of Monolithic Power Systems, Inc.

EV3312-C-00A EVALUATION BOARD

(L x W x H) 5cm x 4.6cm x 1.0cm

Board Number	MPS IC Number
EV3312-C-00A	MP3312

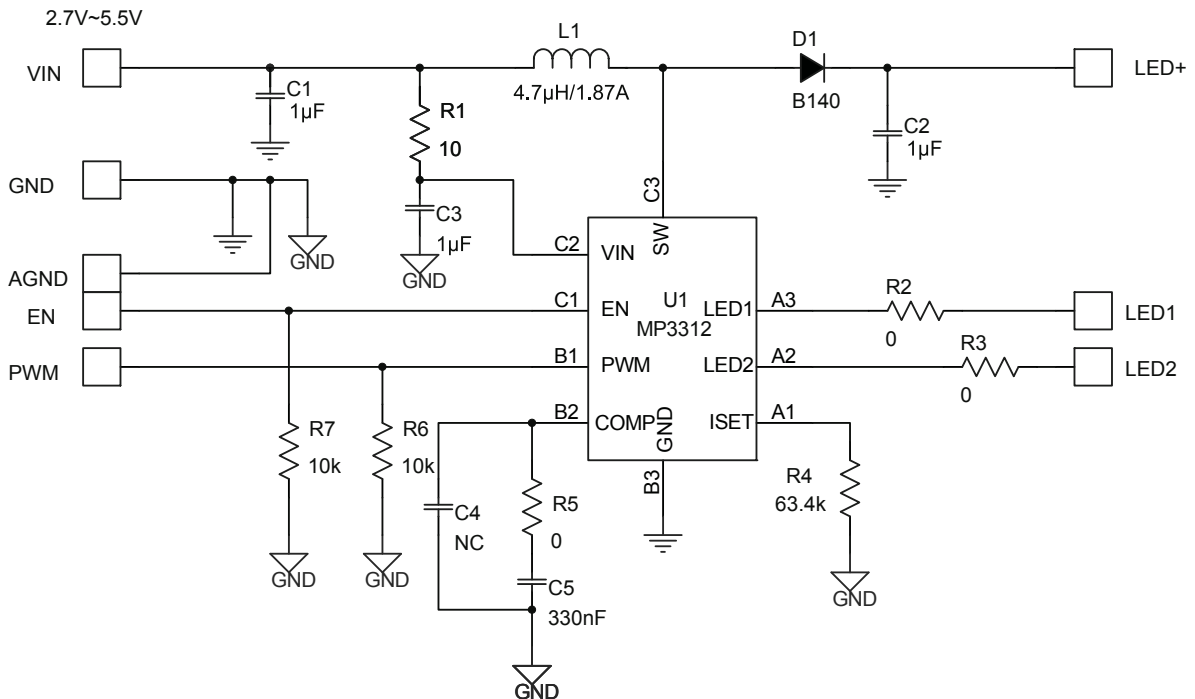
EVALUATION BOARD SCHEMATIC

EV3312-C-00A BILL OF MATERIALS

Qty	Ref	Value	Description	Package	Manufacturer	Manufacturer_P/N
1	C1	1 μ F	Ceramic Capacitor; 25V;X7R;0805	0805	Murata	GRM21BR71E105KA99L
1	C2	1 μ F	Ceramic Capacitor;50V;X7R	1206	Murata	GRM31MR71H105KA88L
1	C3	1 μ F	Ceramic Capacitor; 6.3V;X7R	0603	Murata	GRM188R70J105KA01D
1	C4	NC	CAP/0603			
1	C5	330nF	Ceramic Capacitor; 16V;X7R;0603	0603	TDK	C1608X7R1C334K
1	D1	B140	Schottky Diode;40V;1A;	SMA	Diodes	B140-13-F
1	L1	4.7 μ H/ 1.87A	Inductor;4.7 μ H; 45m;1.87A	SMD	TOKO	D53LC-#A915AY- 4R7M=P3
1	R1	10	Film Resistor;1%;	0603	Yageo	RC0603FR-0710RL
3	R2, R3, R5	0	Film Resistor;5%;	0603	Yageo	RC0603JR-070RL
1	R4	63.4k	Film Resistor;1%	0603	Yageo	RC0603FR-0763K4L
2	R6, R7	10k	Film Resistor;1%;	0603	Yageo	RC0603FR-0710KL
1	U1	MP3312		WLCSP 1.3*1.3	MPS	
8	TP1, TP2, TP3, TP4, TP5, TP6, TP7, TP8	VIN, EN, GND, AGND, PWM, LED+, LED1, LED2	Terminal			

EVB TEST RESULTS

Performance waveforms are tested on the evaluation board.

$V_{IN} = 3.7V$, 6 LEDs in series, 2 strings parallel, 20mA/string, $L = 4.7\mu H$, $T_A = 25^\circ C$, unless otherwise noted.

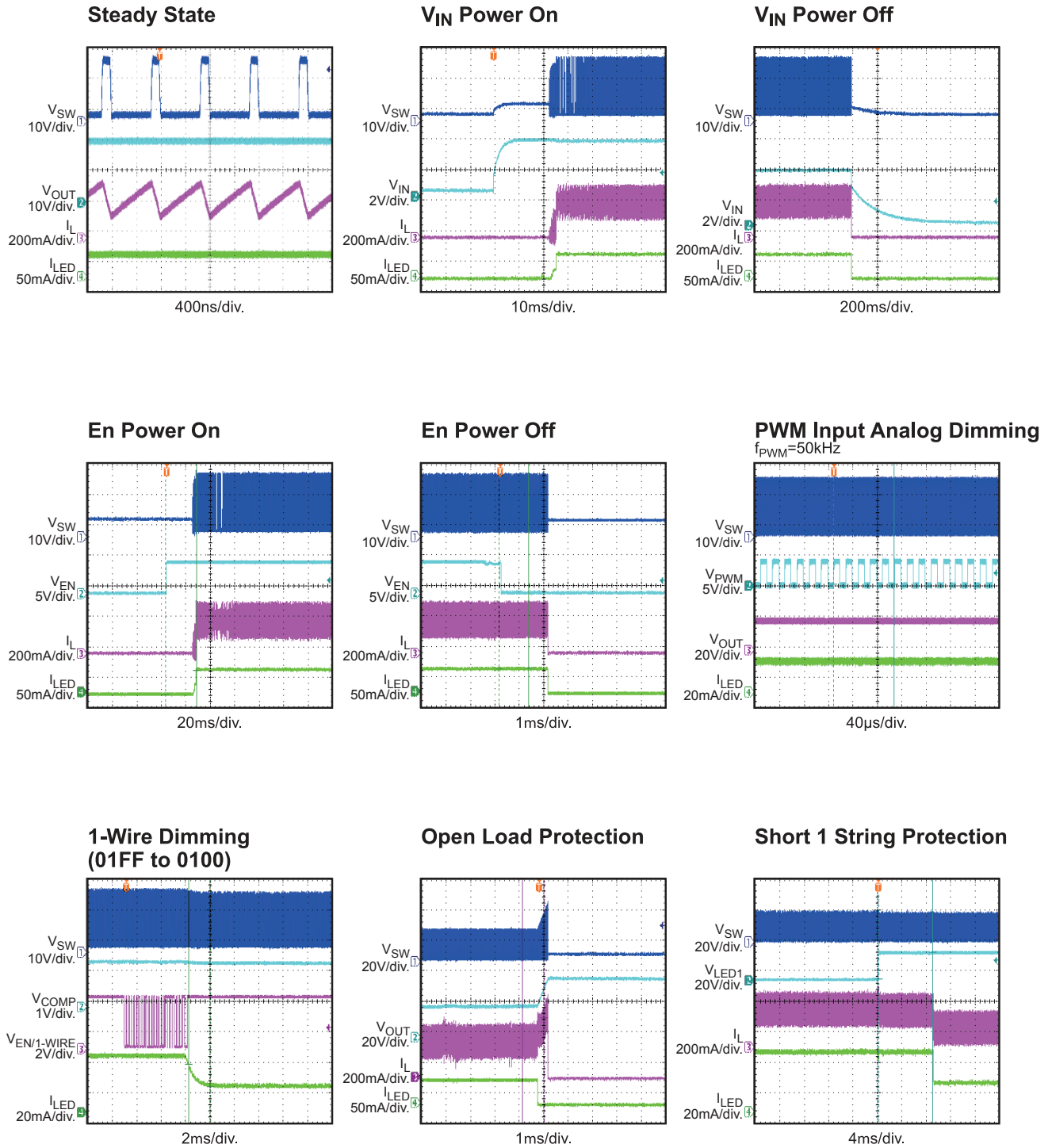

PRINTED CIRCUIT BOARD LAYOUT

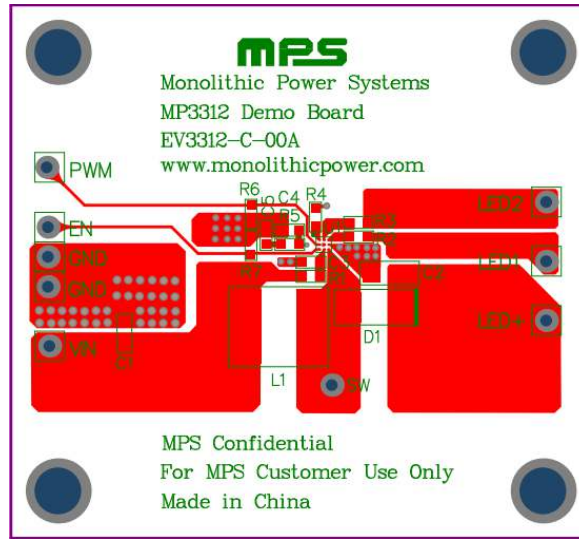

Figure 1: Top Layer

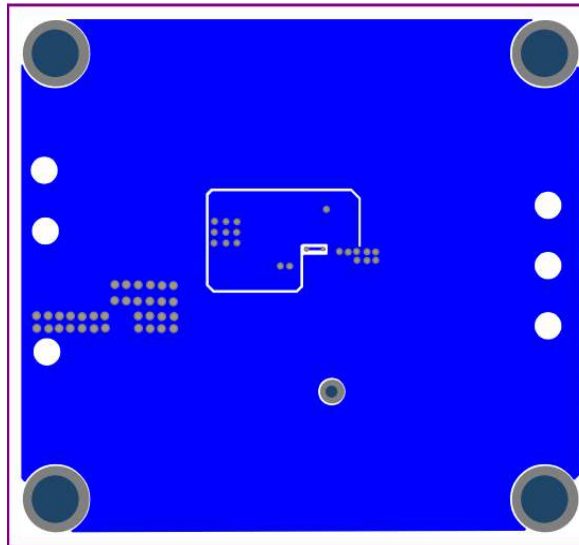

Figure 2: Bottom Layer

QUICK START GUIDE

1. Connect the positive and negative terminals of the load panel (2 strings) to the LED+ and LED1~2 pins on the EV board, respectively.
2. Connect the positive and negative terminals of the power supply (2.7V ~ 5.5V) to the VIN and GND pins on the EV board, respectively.
3. Drive EN pin high (5V) to enable the chip if 1-Wire interface is useless. Apply 1-Wire signal which comes from master to EN pin for digital dimming.
4. Drive PWM DIM pin with 5kHz~100kHz pulse signal for PWM input analog dimming. If PWM input analog dimming is reserved, apply PWM pin high (>1.2V) to set up Chip.
5. Set current of every string by R4.

NOTICE: The information in this document is subject to change without notice. Users should warrant and guarantee that third party Intellectual Property rights are not infringed upon when integrating MPS products into any application. MPS will not assume any legal responsibility for any said applications.