

Figure 1

CONNECTOR PART NUMBER	DESCRIPTION
2008149-1	3-Position Plug
2008150-1	3-Position Receptacle
2008150-1	Pre-Mated Plug and Receptacle
2008149-2	3-Position Plug (Orange)
2008150-2	3-Position Receptacle (Orange)
2008150-2	Pre-Mated Plug and Receptacle (Orange)



NOTE Dimensions in this instruction sheet are in millimeters [with inches in brackets]. Figures and illustrations are for reference only and are not drawn to scale.

Reason for revision are given in Section 7, REVISION SUMMARY.

2. DESCRIPTION

These connectors consist of a plug and a receptacle. Customers may order complete cable assemblies from TE. Refer to the table in Figure 1.

3. ASSEMBLY PROCEDURE



CAUTION In the field, these connectors must be assembled by a qualified electrician in accordance with national and local electrical codes and the following instructions.

Select the proper connector part number for your production requirements.

When selecting connectors 2008149-[], 2008150-[], or 2008152-[] refer to the following procedures:

- Strip wires with 18 AWG solid copper conductors having a maximum insulation diameter of 2.18 mm [.086 in.] to the dimensions provided in Figure 2.

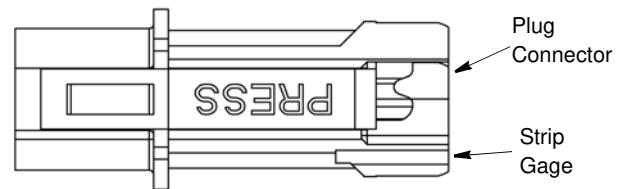

9.53±0.80 [.375±.031]
Recommended Strip Length

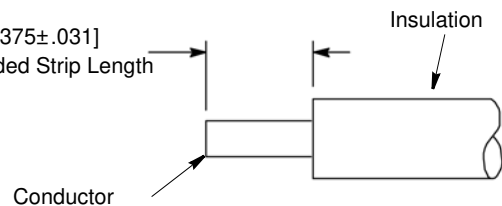

Figure 2

1. INTRODUCTION

This instruction sheet covers the assembly procedures of LIGHT-N-LOK Connectors 2008149-[], 2008150-[], and 2008152-[].



NOTE For detailed application requirements, refer to Application Specification 114-13207.

- Insert each stripped wire into an insertion hole in the back of the plug or receptacle until bottomed. For field wiring, black and white wires must be inserted into corresponding holes marked "B" or "W". This "Wire-Trap Termination" method removes the need for application termination tooling. See Figure 3.



Pull back gently on the wires to ensure they have latched fully into the connectors.

5. Dress the wire 180° to complete the process. See Figure 6.

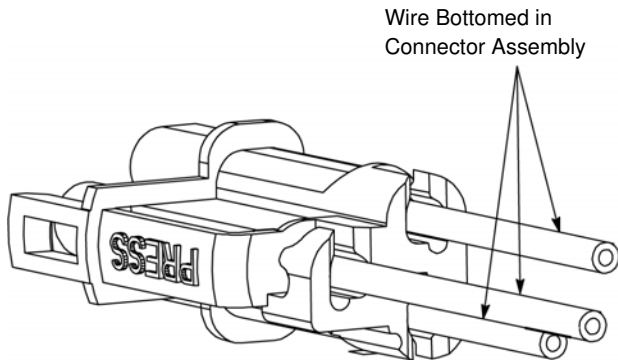

Figure 3

3. Pull the wire down through the slot in the strain-relief. See Figure 4.

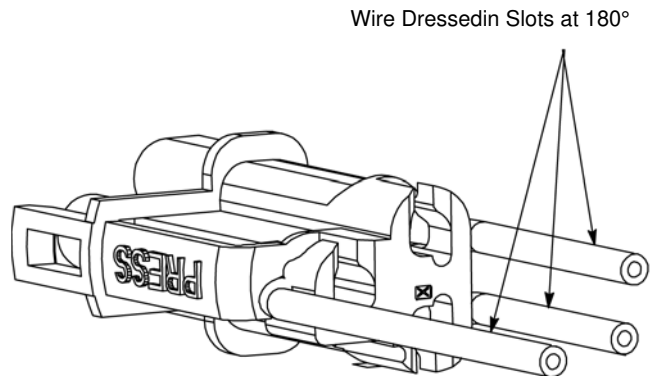

Figure 6

6. Apply optional approved flammability rated tape or clamp to organize the wires. See Figure 7.

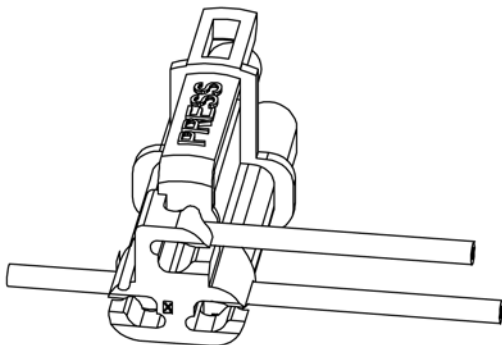

Figure 4

4. Rotate the wire 90°. See Figure 5.

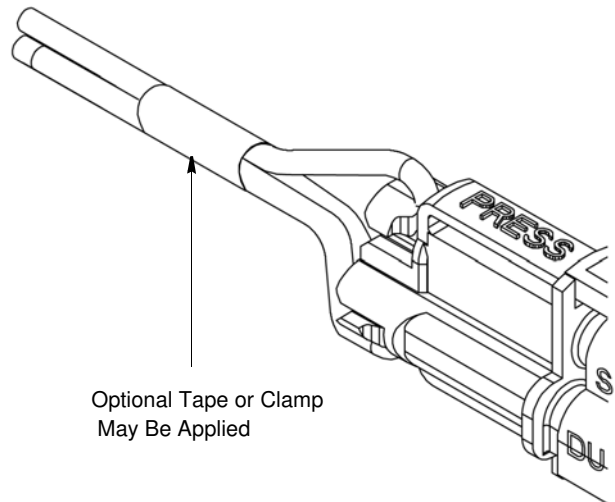

Figure 7



Figure 5

4. CONNECTOR MATING

Align the polarized mating faces of the connectors, and push the connectors together. DO NOT force the connectors to mate. When fully mated, the connectors must appear bottomed with each other and flush at the point of engagement. An audible and tactile "click" will be heard and felt. See Figure 8.

5. CONNECTOR UNMATING



To reduce risk of electric shock, DISCONNECT the electrical supply before unmating the connectors

To unmate the connectors, squeeze the release latches on either side of the plug and pull back until both connectors separate from each other.



Do NOT pull on wires when unmating the connectors.

6. REPLACEMENT AND REPAIR

The contacts and connectors, are not repairable. DO NOT use damaged or defective contacts or connectors. DO NOT remove the wire and re-terminate contacts.

7. REVISION SUMMARY

Since the previous release of these instructions, product has been added to Figure 1.

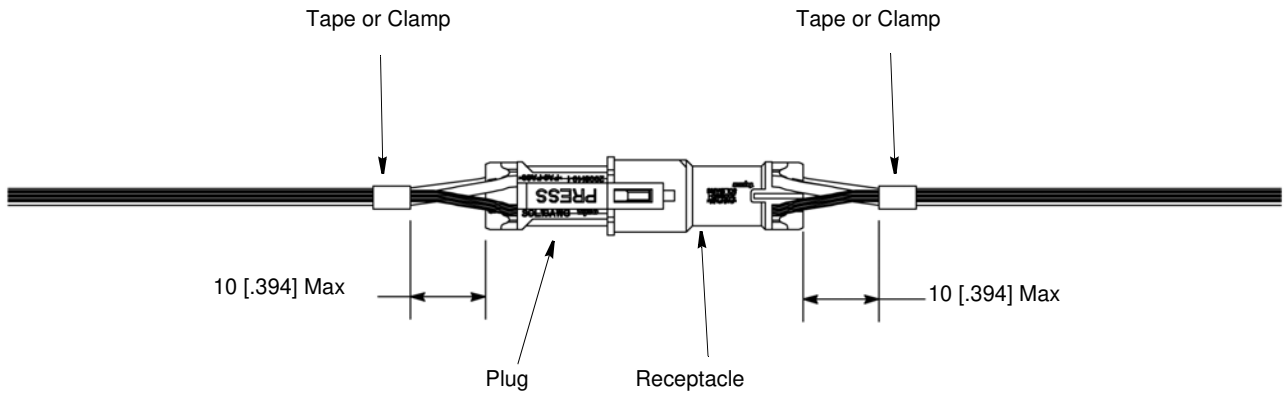

Figure 8