

FSA3031 — Dual High-Speed USB2.0 with Mobile High-Definition Link (MHL™)

Features

- Low On Capacitance: 4.6 pF/6.75 pF MHL/USB (Typical)
- Low Power Consumption: 30 μ A Maximum
- Supports MHL Rev. 2.0
- Passes 1080 p/60 fps (3 Gbps) MHL Data Eye Diagram Mask Compliance
- MHL Data Rate: \geq 4.7Gbps with Ideal Input Source
- Packaged in 12-Lead UMLP (1.8 x 1.8 mm)
- Over-Voltage Tolerance (OVT) on all USB Ports Up to 5.25 V without External Components

Applications

- Cell Phones and Digital Cameras

IMPORTANT NOTE:

For additional performance information, please contact interface@fairchildsemi.com.

Description

The FSA3031 is a bi-directional, low-power, high-speed, 3:1, dual USB2.0 and MHL switch. Configured as a double-pole, triple-throw (DP3T) switch; it is optimized for switching between dual high- or full-speed USB and Mobile High-Definition Link sources (MHL™ Rev. 2.0 specification).

The FSA3031 contains special circuitry on the switch I/O pins, for applications where the V_{CC} supply is powered off ($V_{CC}=0$), that allows the device to withstand an over-voltage condition. This switch is designed to minimize current consumption even when the control voltage applied to the control pins is lower than the supply voltage (V_{CC}). This feature is especially valuable to mobile applications, such as cell phones; allowing direct interface with the general-purpose I/Os of the baseband processor. Other applications include switching and connector sharing in portable cell phones, digital cameras, and notebook computers.

Ordering Information

Part Number	Top Mark	Operating Temperature Range	Package
FSA3031UMX	LX	-40 to +85°C	12-Lead, Ultrathin Molded Leadless Package (UMLP), 1.8 mm x 1.8 mm

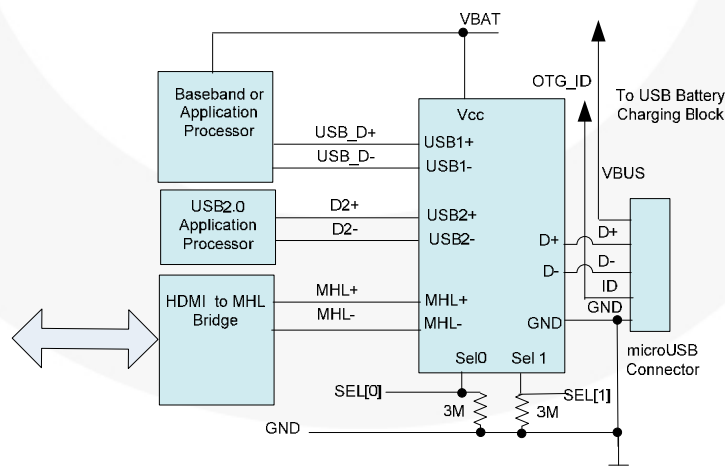

Figure 1. Typical Application

All trademarks are the property of their respective owners.

Analog Symbol

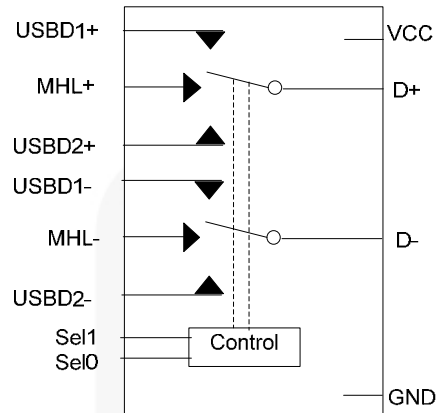

Figure 2. Analog Symbol

Table 1. Data Switch Select Truth Table

SEL1 ⁽¹⁾	SEL0 ⁽¹⁾	Function
0	0	D+/D- connected to USB1+/USB1-
0	1	D+/D- connected to USB2+/USB2-
1	0	D+/D- connected to MHL+/MHL
1	1	D+/D- high impedance

Note:

- Control inputs should never be left floating or unconnected. To guarantee default switch closure to the USB position, the SEL[0:1] pins should be tied to GND with a weak pull-down resistor (3 MΩ) to minimize static current draw.

Pin Configuration

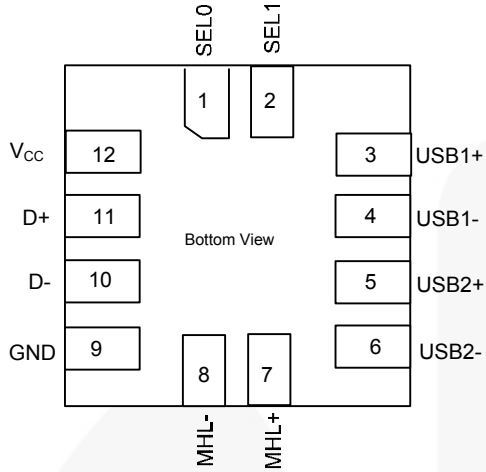

Figure 3. Pin Assignments

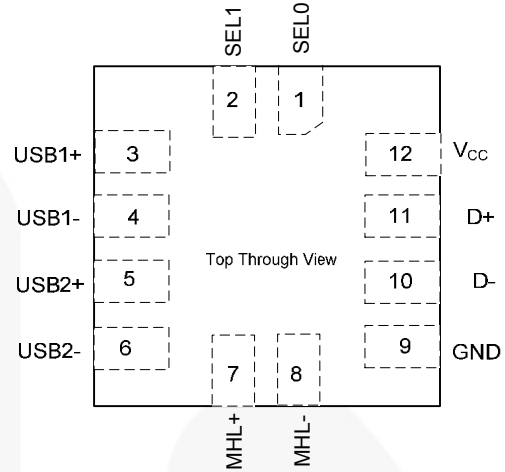

Figure 4. Top Through View

Pin Definitions

Pin#	Name	Description
1	SEL0	Data Switch Select
2	SEL1	Data Switch Select
3	USB1+	USB Differential Data (Positive) – Source 1
4	USB1-	USB Differential Data (Negative) – Source 1
5	USB2+	USB Differential Data (Positive) – Source 2
6	USB2-	USB Differential Data (Negative) – Source 2
7	MHL+	MHL Differential Data (Positive)
8	MHL-	MHL Differential Data (Negative)
9	GND	Ground
10	D-	Data Switch Output (Positive)
11	D+	Data Switch Output (Negative)
12	V _{CC}	Device Power from System

Absolute Maximum Ratings

Stresses exceeding the absolute maximum ratings may damage the device. The device may not function or be operable above the recommended operating conditions and stressing the parts to these levels is not recommended. In addition, extended exposure to stresses above the recommended operating conditions may affect device reliability. The absolute maximum ratings are stress ratings only.

Symbol	Parameter		Min.	Max.	Unit
V _{CC}	Supply Voltage		-0.5	6.0	V
V _{CNTRL}	DC Input Voltage (SEL[1:0]) ⁽²⁾		-0.5	V _{CC}	V
V _{SW} ⁽³⁾	DC Switch I/O Voltage ⁽²⁾	USB	-0.50	V _{CC}	V
		MHL	-0.50	V _{CC}	
I _{IK}	DC Input Diode Current		-50		mA
I _{OUT}	Switch DC Output Current (Continuous)	USB		60	mA
		MHL		60	mA
I _{OUTPEAK}	Switch DC Output Peak Current (Pulsed at 1m Duration, <10% Duty Cycle)	USB		150	mA
		MHL		150	mA
T _{STG}	Storage Temperature		-65	+150	°C
MSL	Moisture Sensitivity Level (JEDEC J-STD-020A)			1	
ESD	Human Body Model, JEDEC: JESD22-A114	All Pins		4	kV
	IEC 61000-4-2, Level 4, for D+/D- and V _{CC} Pins ⁽⁴⁾	Contact		8	
	IEC 61000-4-2, Level 4, for D+/D- and V _{CC} Pins ⁽⁴⁾	Air		15	
	Charged Device Model, JESD22-C101			2	

Notes:

- The input and output negative ratings may be exceeded if the input and output diode current ratings are observed.
- V_{SW} refers to analog data switch paths (USB1, MHL, and USB2).
- Testing performed in a system environment using TVS diodes.

Recommended Operating Conditions

The Recommended Operating Conditions table defines the conditions for actual device operation. Recommended operating conditions are specified to ensure optimal performance to the datasheet specifications. Fairchild does not recommend exceeding them or designing to Absolute Maximum Ratings.

Symbol	Parameter	Min.	Max.	Unit
V _{CC}	Supply Voltage	2.5	4.5	V
t _{RAMP(VCC)}	Power Supply Slew Rate	100	1000	µs/V
θ _{JA}	Thermal Resistance		230	C°/W
V _{CNTRL}	Control Input Voltage (SEL[1:0]) ⁽⁵⁾	0	4.5	V
V _{SW(USB)}	Switch I/O Voltage (USB1/USB2 Switch Paths)	-0.5	3.6	V
V _{SW(MHL)}	Switch I/O Voltage (MHL Switch Path)	1.65	3.45	V
T _A	Operating Temperature	-40	+85	°C

Note:

- The control inputs must be held HIGH or LOW; they must not float.

DC Electrical Characteristics

All typical values are at $T_A=25^\circ\text{C}$ unless otherwise specified.

Symbol	Parameter	Condition	V_{CC} (V)	$T_A=-40^\circ\text{C}$ to $+85^\circ\text{C}$			Unit
				Min.	Typ.	Max.	
V_{IK}	Clamp Diode Voltage	$I_{IN}=-18\text{ mA}$	2.5			-1.2	V
V_{IH}	Control Input Voltage, High SEL[1:0]		2.5 to 4.5	1.0			V
V_{IL}	Control Input Voltage, Low SEL[1:0]		2.5 to 4.5			0.5	V
I_{IN}	Control Input Leakage, SEL[1:0]	$V_{SW}=0$ to 3.6 V, $V_{CNTRL}=0$ to V_{CC}	4.5	-0.5		0.5	μA
$I_{OZ(MHL)}$	Off-State Leakage for Open MHL Data Paths	$V_{SW}=1.65 \leq \text{MHL} \leq 3.45\text{ V}$, SEL[1:0]= V_{CC}	4.5	-0.5		0.5	μA
$I_{OZ(USB)}$	Off-State Leakage for Open USB Data Paths	$V_{SW}=0 \leq \text{USB} \leq 3.6\text{ V}$, SEL[1:0]= V_{CC}	4.5	-0.5		0.5	μA
$I_{CL(MHL)}$	On-State Leakage for Closed MHL Data Paths ⁽⁶⁾	$V_{SW}=1.65 \leq \text{MHL} \leq 3.45\text{ V}$, SEL0=GND, SEL1= V_{CC} , Other Side of Switch Float	4.5	-0.5		0.5	μA
$I_{CL(USB)}$	On-State Leakage for Closed USB Data Paths ⁽⁶⁾	$V_{SW}=0 \leq \text{USB} \leq 3.6\text{ V}$, SEL[1:0]=GND or SEL1=GND, SEL0= V_{CC} , Other Side of Switch Float	4.5	-0.5		0.5	μA
I_{OFF}	Power-Off Leakage Current (All I/O Ports)	$V_{SW}=0\text{ V}$ or 3.6 V, Figure 5	0	-0.5		0.5	μA
$R_{ON(USB)}$	HS Switch On Resistance (USB to D Path)	$V_{SW}=0.4\text{ V}$, $I_{ON}=-8\text{ mA}$, SEL[1:0]=GND or SEL1=GND, SEL0= V_{CC} , Figure 6	2.5		3.9	6.5	Ω
$R_{ON(MHL)}$	HS Switch On Resistance (MHL to D Path)	$V_{SW}=V_{CC}-1050\text{ mV}$, SEL0=GND, SEL1= V_{CC} , $I_{ON}=-8\text{ mA}$, Figure 6	2.5		5		Ω
$\Delta R_{ON(MHL)}$	Difference in R_{ON} Between MHL Positive-Negative	$V_{SW}=V_{CC}-1050\text{ mV}$, SEL0=GND, SEL1= V_{CC} , $I_{ON}=-8\text{ mA}$, Figure 6,	2.5		0.03		Ω
$\Delta R_{ON(USB)}$	Difference in R_{ON} Between USB Positive-Negative	$V_{SW}=0.4\text{ V}$, $I_{ON}=-8\text{ mA}$, SEL[1:0]=GND or SEL1=GND, SEL0= V_{CC} Figure 6	2.5		0.22		Ω
$R_{ONF(MHL)}$	Flatness for R_{ON} MHL Path	$V_{SW}=1.65$ to 3.45 V, SEL0=GND, SEL1= V_{CC} , $I_{ON}=-8\text{ mA}$, Figure 6	2.5		1		Ω
I_{CC}	Quiescent Current	$V_{CNTRL}=0$ or 4.5 V, $I_{OUT}=0$	4.5			30	μA
I_{CCT}	Delta Increase in Quiescent Current per Control Pin	$V_{CNTRL}=1.65\text{ V}$, $I_{OUT}=0$	4.5			18	μA
		$V_{CNTRL}=2.5\text{ V}$, $I_{OUT}=0$	4.5			10	

Note:

6. For this test, the data switch is closed with the respective switch pin floating.

AC Electrical Characteristics

All typical values are for $V_{CC}=3.3\text{ V}$ and $T_A=25^\circ\text{C}$ unless otherwise specified.

Symbol	Parameter	Condition	V_{CC} (V)	$T_A=-40^\circ\text{C to }+85^\circ\text{C}$			Unit
				Min.	Typ.	Max.	
t_{ONUSB}	USB Turn-On Time, SEL[1:0] to Output	$R_L=50\ \Omega$, $C_L=5\ \text{pF}$, $V_{SW(USB)}=0.8\ \text{V}$, $V_{SW(MHL)}=3.3\ \text{V}$, Figure 7, Figure 8	2.5 to 3.6		445	600	ns
t_{OFFUSB}	USB Turn-Off Time, SEL[1:0] to Output	$R_L=50\ \Omega$, $C_L=5\ \text{pF}$, $V_{SW(USB)}=0.8\ \text{V}$, $V_{SW(MHL)}=3.3\ \text{V}$, Figure 7, Figure 8	2.5 to 3.6		445	600	ns
t_{ONMHL}	MHL Turn-On Time, SEL[1:0] to Output	$R_L=50\ \Omega$, $C_L=5\ \text{pF}$, $V_{SW(USB)}=0.8\ \text{V}$, $V_{SW(MHL)}=3.3\ \text{V}$, Figure 7, Figure 8	2.5 to 3.6		445	600	ns
t_{OFFMHL}	MHL Turn-Off Time, SEL[1:0] to Output	$R_L=50\ \Omega$, $C_L=5\ \text{pF}$, $V_{SW(USB)}=0.8\ \text{V}$, $V_{SW(MHL)}=3.3\ \text{V}$, Figure 7, Figure 8	2.5 to 3.6		445	600	ns
t_{PD}	Propagation Delay ⁽⁷⁾	$C_L=5\ \text{pF}$, $R_L=50\ \Omega$, Figure 7, Figure 9	2.5 to 3.6		0.25		ns
t_{BBM}	Break-Before-Make Time ⁽⁷⁾	$R_L=50\ \Omega$, $C_L=5\ \text{pF}$, $V_{ID}=V_{MHL}=3.3\ \text{V}$, $V_{USB}=0.8\ \text{V}$, Figure 11	2.5 to 3.6		85		ns
$O_{IRR(MHL)}$	Off Isolation ⁽⁷⁾	$V_S=1\ \text{V}_{pk-pk}$, $R_L=50\ \Omega$, $f=240\ \text{MHz}$, Figure 12	2.5 to 3.6		-41		dB
$O_{IRR(USB)}$		$V_S=400\ \text{mV}_{pk-pk}$, $R_L=50\ \Omega$, $f=240\ \text{MHz}$, Figure 12	2.5 to 3.6		-36		dB
$Xtalk_{MHL}$	Non-Adjacent Channel ⁽⁷⁾ Crosstalk	$V_S=1\ \text{V}_{pk-pk}$, $R_L=50\ \Omega$, $f=240\ \text{MHz}$, Figure 13	2.5 to 3.6		-41		dB
$Xtalk_{USB}$		$V_S=400\ \text{mV}_{pk-pk}$, $R_L=50\ \Omega$, $f=240\ \text{MHz}$, Figure 13	2.5 to 3.6		-37		dB
BW	Differential -3db Bandwidth ⁽⁷⁾	$V_{IN}=1\ \text{V}_{pk-pk}$, MHL Path, Common Mode Voltage = $V_{CC} - 1.1\ \text{V}$, $R_L=50\ \Omega$, $C_L=0\ \text{pF}$, Figure 14	2.5 to 3.6		1.87		GHz
		$V_{IN}=400\ \text{mV}_{pk-pk}$, USB Path, Common Mode Voltage = $0.2\ \text{V}$, $R_L=50\ \Omega$, $C_L=0\ \text{pF}$, Figure 14			1.47		

Note:

7. Guaranteed by characterization.

USB High-Speed AC Electrical Characteristics

Typical values are at $T_A = -40^\circ\text{C}$ to $+85^\circ\text{C}$.

Symbol	Parameter	Condition	$V_{CC}(V)$	Typ.	Unit
$t_{SK(P)}$	Skew of Opposite Transitions of the Same Output ⁽⁸⁾	$C_L=5\text{ pF}$, $R_L=50\ \Omega$, Figure 9	3.0 to 3.6	7	ps
t_J	Total Jitter ⁽⁸⁾	$R_L=50\ \Omega$, $C_L=5\text{ pF}$, $t_R=t_F=500\text{ ps}$ (10-90%) at 480 Mbps, PN7	3.0 to 3.6	18	ps

Note:

8. Guaranteed by characterization.

MHL AC Electrical Characteristics

Typical values are at $T_A = -40^\circ\text{C}$ to $+85^\circ\text{C}$.

Symbol	Parameter	Condition	$V_{CC}(V)$	Typ.	Unit
$t_{SK(P)}$	Skew of Opposite Transitions of the Same Output ⁽⁹⁾	$R_{PU}=50\ \Omega$ to V_{CC} , $C_L=0\text{ pF}$	3.0 to 3.6	3	ps
t_J	Total Jitter ⁽⁹⁾	$f=2.25\text{ Gbps}$, PN7, $R_{PU}=50\ \Omega$ to V_{CC} , $C_L=0\text{ pF}$	3.0 to 3.6	23	ps

Note:

9. Guaranteed by characterization.

Capacitance

Typical values are at $T_A = -40^\circ\text{C}$ to $+85^\circ\text{C}$.

Symbol	Parameter	Condition	Typ.	Max.	Unit
C_{IN}	Control Pin Input Capacitance ⁽¹⁰⁾	$V_{CC}=0\text{ V}$, $f=1\text{ MHz}$	2.5		pF
$C_{ON(USB)}$	USB Path On Capacitance ⁽¹⁰⁾	$V_{CC}=3.3\text{ V}$, $f=240\text{ MHz}$, Figure 15	6.75		pF
$C_{OFF(USB)}$	USB Path Off Capacitance ⁽¹⁰⁾	$V_{CC}=3.3\text{ V}$, $f=240\text{ MHz}$, Figure 13	2.5		pF
$C_{ON(MHL)}$	MHL Path On Capacitance ⁽¹⁰⁾	$V_{CC}=3.3\text{ V}$, $f=240\text{ MHz}$, Figure 15	4.6		pF
$C_{OFF(MHL)}$	MHL Path Off Capacitance ⁽¹⁰⁾	$V_{CC}=3.3\text{ V}$, $f=240\text{ MHz}$, Figure 13	2.5		pF

Note:

10. Guaranteed by characterization.

Test Diagrams

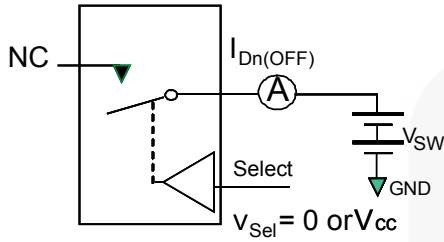

**Each switch port is tested separately

Figure 5. Off Leakage

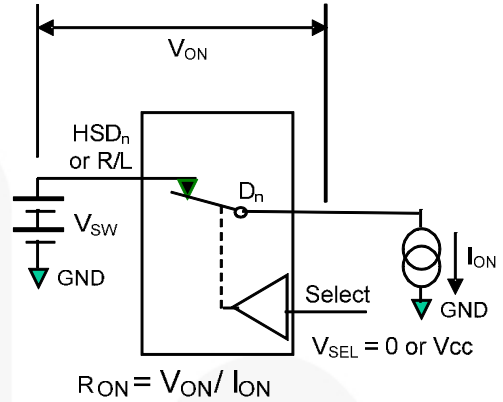
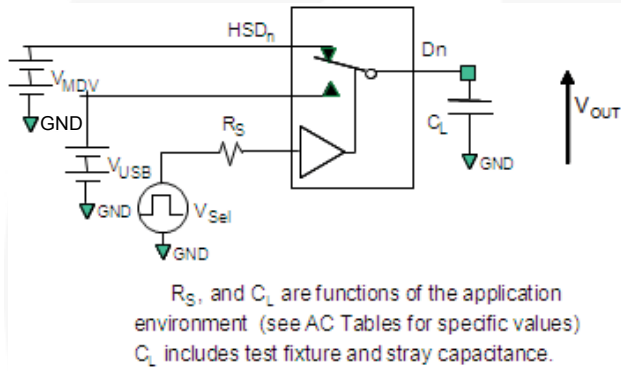

Figure 6. On Resistance



R_S and C_L are functions of the application environment (see AC Tables for specific values)
 C_L includes test fixture and stray capacitance.

Figure 7. AC Test Circuit Load

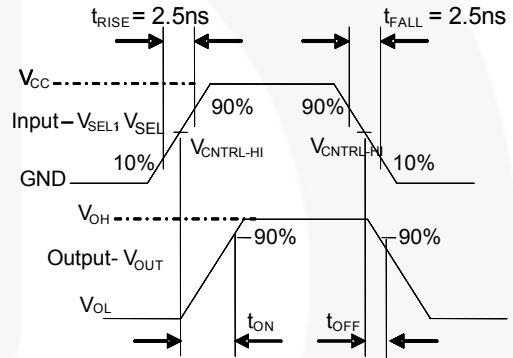

Figure 8. Turn-On / Turn-Off Waveforms

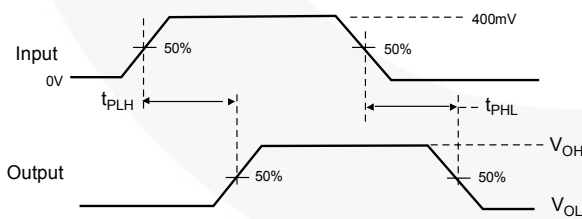

Figure 9. Propagation Delay ($t_{RT} = 500ps$)

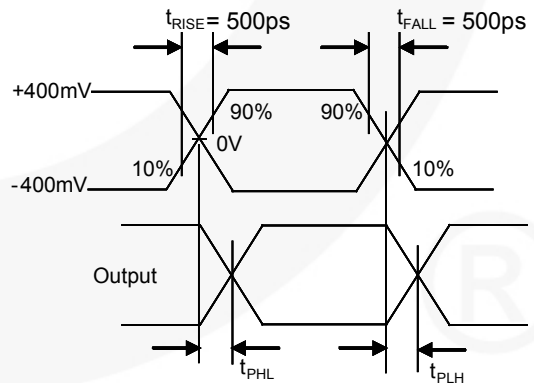
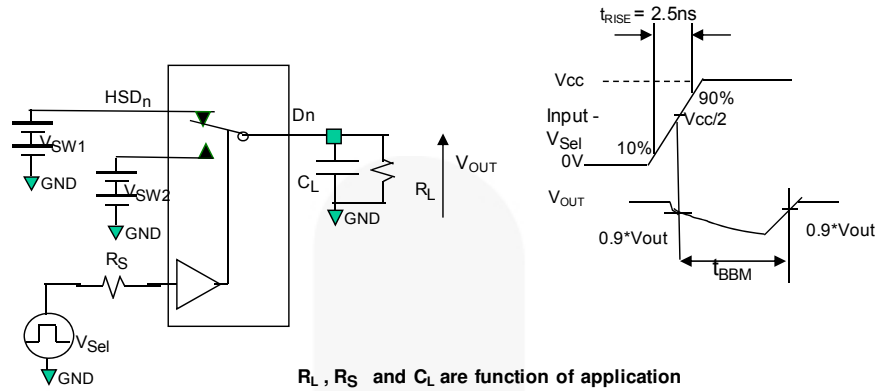

Figure 10. Intra-Pair Skew Test $t_{SK(P)}$

Test Diagrams



R_L , R_S and C_L are function of application environment (see AC Tables for specific values)
 C_L includes test fixture and stray capacitance

Figure 11. Break-Before-Make Interval Timing

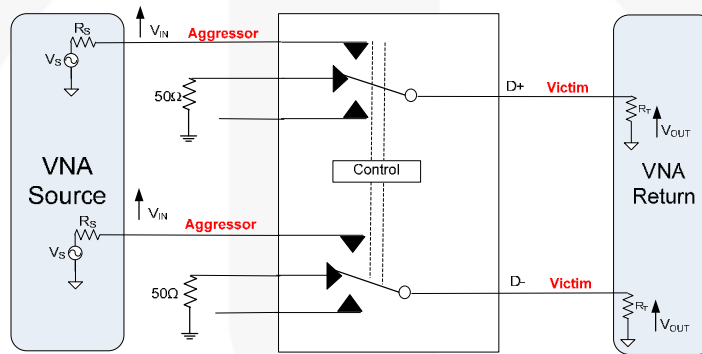

V_S , R_S and R_T are functions of the application environment (see AC/DC Tables for values).
 Off Isolation = $20 \text{ Log } (V_{OUT} - V_{IN})$

Figure 12. Channel Off Isolation (SDD21)

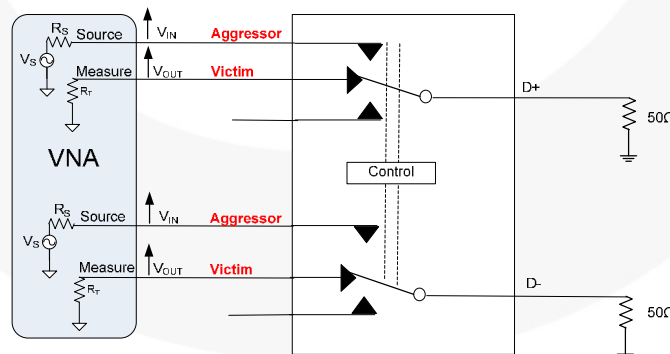

V_S , R_S and R_T are functions of the application environment (see AC/DC Tables for values).
 Off Isolation = $20 \text{ Log } (V_{OUT} - V_{IN})$

Figure 13. Non-Adjacent Channel-to-Channel Crosstalk (SDD21)

Test Diagrams

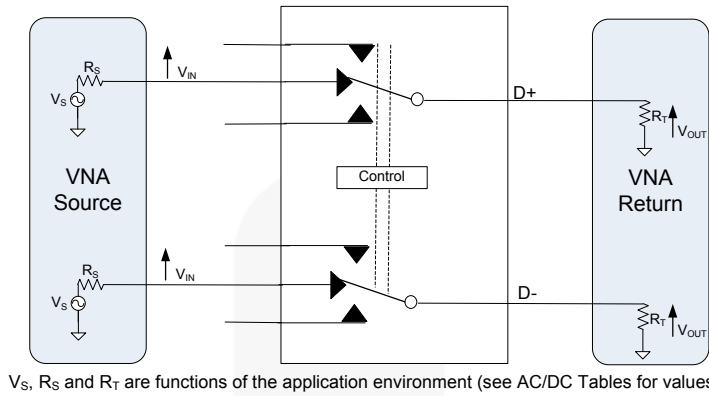

Figure 14. Insertion Loss (SDD21)

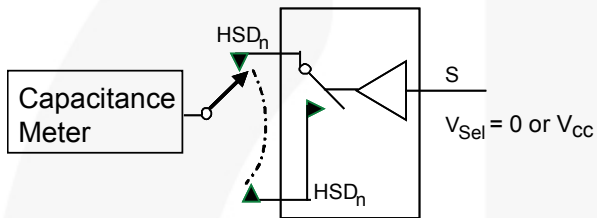

Figure 15. Channel Off Capacitance

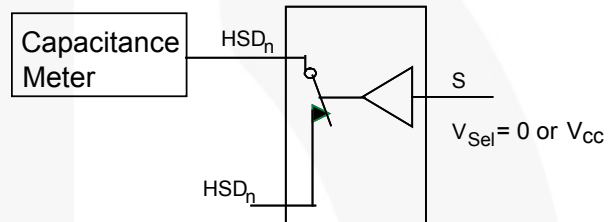

Figure 16. Channel On Capacitance

Note:

11. HSD_n refers to the high-speed data USB or MHL paths.

Functional Description

Insertion Loss

One of the key advantages of using the FSA3031 in mobile digital video applications is the small amount of insertion loss experienced by the received signal as it passes through the switch.

This results in minimal degradation of the received eye. One of the ways to measure the quality of the high data rate channels is using balanced ports and four-port differential S-parameter analysis, particularly SDD21.

Bandwidth is measured using the S-parameter SDD21 methodology. Figure 17 exhibits the 1.87 GHz (-3 db) BW of the MHL path, while Figure 18 exhibits the 1.47 GHz (-3 db) BW of the USB paths.



Figure 17. MHL Path SDD21 Insertion Loss Curve



Figure 18. USB Path SDD21 Insertion Loss Curve

Typical Application

Figure 19 shows utilizing the VBAT connection from the micro-USB connector. The 3M resistors are used to ensure, for manufacturing test via the micro-USB connector, that the FSA3031 configures for connectivity to the baseband or application processor.

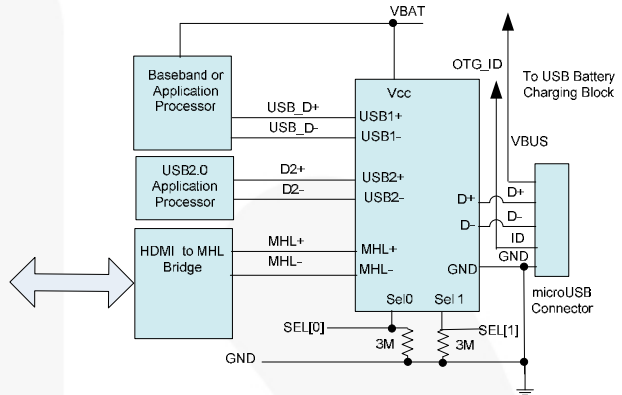

Figure 19. Typical Application

Physical Dimensions

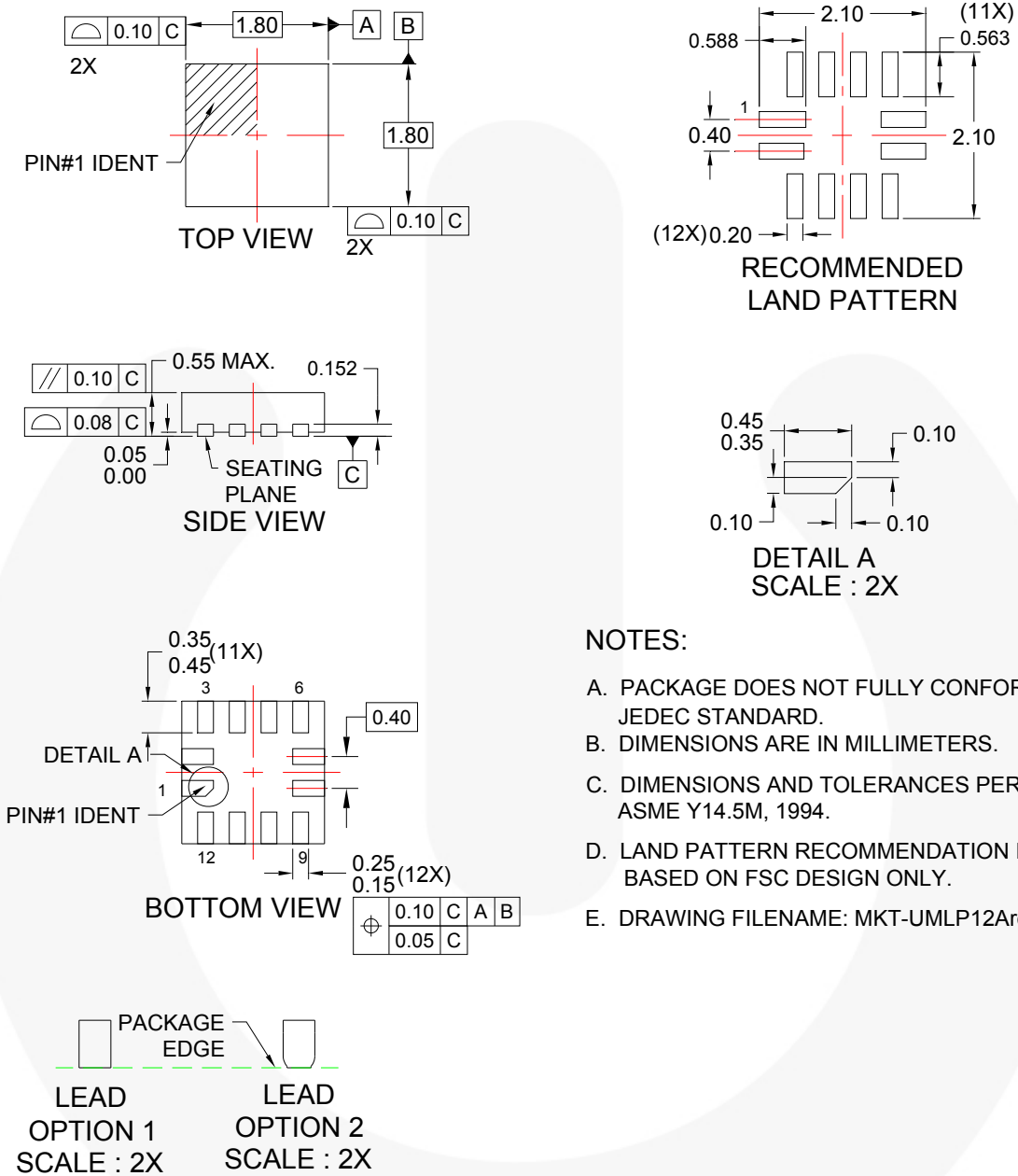

Figure 20. 12-Lead, Ultrathin Molded Leadless Package (UMLP)

Package drawings are provided as a service to customers considering Fairchild components. Drawings may change in any manner without notice. Please note the revision and/or date on the drawing and contact a Fairchild Semiconductor representative to verify or obtain the most recent revision. Package specifications do not expand the terms of Fairchild's worldwide terms and conditions, specifically the warranty therein, which covers Fairchild products.

Always visit Fairchild Semiconductor's online packaging area for the most recent package drawings:
<http://www.fairchildsemi.com/packaging/>.



TRADEMARKS

The following includes registered and unregistered trademarks and service marks, owned by Fairchild Semiconductor and/or its global subsidiaries, and is not intended to be an exhaustive list of all such trademarks.

2Cool™
 AccuPower™
 AX-CAP™*
 BitSiC™
 Build it Now™
 CorePLUS™
 CorePOWER™
 CROSSVOLT™
 CTL™
 Current Transfer Logic™
 DEUXPEED®
 Dual Cool™
 EcoSPARK®
 EfficientMax™
 ESBC™

 Fairchild®
 Fairchild Semiconductor®
 FACT Quiet Series™
 FACT®
 FAST®
 FastvCore™
 FETBench™
 FlashWriter®*
 FPS™

F-PFS™
 FRFET®
 Global Power Resource™
 GreenBridge™
 Green FPS™
 Green FPS™ e-Series™
 Gmax™
 GTO™
 IntelliMAX™
 ISOPLANAR™
 Making Small Speakers Sound Louder and Better™
 MegaBuck™
 MICROCOUPLER™
 MicroFET™
 MicroPak™
 MicroPak2™
 MillerDrive™
 MotionMax™
 mWSaver™
 OptoHit™
 OPTOLOGIC®
 OPTOPLANAR®

PowerTrench®
 PowerXS™
 Programmable Active Droop™
 QFET®
 QS™
 Quiet Series™
 RapidConfigure™

 Saving our world, 1mW/W/kW at a time™
 SignalWise™
 SmartMax™
 SMART START™
 Solutions for Your Success™
 SPM®
 STEALTH™
 SuperFET®
 SuperSOT™-3
 SuperSOT™-6
 SuperSOT™-8
 SupreMOS®
 SyncFET™
 Sync-Lock™

The Power Franchise®

 TinyBoost™
 TinyBuck™
 TinyCalc™
 TinyLogic®
 TINYOPTO™
 TinyPower™
 TinyPWM™
 TinyWire™
 TranSiC™
 TriFault Detect™
 TRUECURRENT®*
 µSerDes™

 UHC®
 Ultra FRFET™
 UniFET™
 VCX™
 VisualMax™
 VoltagePlus™
 XS™

* Trademarks of System General Corporation, used under license by Fairchild Semiconductor.

DISCLAIMER

FAIRCHILD SEMICONDUCTOR RESERVES THE RIGHT TO MAKE CHANGES WITHOUT FURTHER NOTICE TO ANY PRODUCTS HEREIN TO IMPROVE RELIABILITY, FUNCTION, OR DESIGN. FAIRCHILD DOES NOT ASSUME ANY LIABILITY ARISING OUT OF THE APPLICATION OR USE OF ANY PRODUCT OR CIRCUIT DESCRIBED HEREIN; NEITHER DOES IT CONVEY ANY LICENSE UNDER ITS PATENT RIGHTS, NOR THE RIGHTS OF OTHERS. THESE SPECIFICATIONS DO NOT EXPAND THE TERMS OF FAIRCHILD'S WORLDWIDE TERMS AND CONDITIONS, SPECIFICALLY THE WARRANTY THEREIN, WHICH COVERS THESE PRODUCTS.

LIFE SUPPORT POLICY

FAIRCHILD'S PRODUCTS ARE NOT AUTHORIZED FOR USE AS CRITICAL COMPONENTS IN LIFE SUPPORT DEVICES OR SYSTEMS WITHOUT THE EXPRESS WRITTEN APPROVAL OF FAIRCHILD SEMICONDUCTOR CORPORATION.

As used herein:

1. Life support devices or systems are devices or systems which, (a) are intended for surgical implant into the body or (b) support or sustain life, and (c) whose failure to perform when properly used in accordance with instructions for use provided in the labeling, can be reasonably expected to result in a significant injury of the user.
2. A critical component in any component of a life support, device, or system whose failure to perform can be reasonably expected to cause the failure of the life support device or system, or to affect its safety or effectiveness.

ANTI-COUNTERFEITING POLICY

Fairchild Semiconductor Corporation's Anti-Counterfeiting Policy. Fairchild's Anti-Counterfeiting Policy is also stated on our external website, www.fairchildsemi.com, under Sales Support.

Counterfeiting of semiconductor parts is a growing problem in the industry. All manufacturers of semiconductor products are experiencing counterfeiting of their parts. Customers who inadvertently purchase counterfeit parts experience many problems such as loss of brand reputation, substandard performance, failed applications, and increased cost of production and manufacturing delays. Fairchild is taking strong measures to protect ourselves and our customers from the proliferation of counterfeit parts. Fairchild strongly encourages customers to purchase Fairchild parts either directly from Fairchild or from Authorized Fairchild Distributors who are listed by country on our web page cited above. Products customers buy either from Fairchild directly or from Authorized Fairchild Distributors are genuine parts, have full traceability, meet Fairchild's quality standards for handling and storage and provide access to Fairchild's full range of up-to-date technical and product information. Fairchild and our Authorized Distributors will stand behind all warranties and will appropriately address any warranty issues that may arise. Fairchild will not provide any warranty coverage or other assistance for parts bought from Unauthorized Sources. Fairchild is committed to combat this global problem and encourage our customers to do their part in stopping this practice by buying direct or from authorized distributors.

PRODUCT STATUS DEFINITIONS

Definition of Terms

Datasheet Identification	Product Status	Definition
Advance Information	Formative / In Design	Datasheet contains the design specifications for product development. Specifications may change in any manner without notice.
Preliminary	First Production	Datasheet contains preliminary data; supplementary data will be published at a later date. Fairchild Semiconductor reserves the right to make changes at any time without notice to improve design.
No Identification Needed	Full Production	Datasheet contains final specifications. Fairchild Semiconductor reserves the right to make changes at any time without notice to improve the design.
Obsolete	Not In Production	Datasheet contains specifications on a product that is discontinued by Fairchild Semiconductor. The datasheet is for reference information only.

Rev. I62