

NOTES:

1.0 MATERIALS:

- 1.1 HOUSING & COUPLING NUT:
STAINLESS STEEL PER ASTM-A582, TYPE 303.
- 1.2 CENTER CONTACT: BERYLLIUM COPPER ROD
ALLOY C172, ASTM-B194.
- 1.3 DIELECTRIC: PTFE FLUOROCARBON PER ASTM-D1457.

2.0 PLATING:

- 2.1 HOUSING: PASSIVATED PER
QQ-P-35 AND MIL-F-14072.
- 2.2 CENTER CONTACT: GOLD PER MIL-G-45204
TYPE II, CLASS 2
- 2.3 COUPLING NUT: ELECTROPOLISH (BRIGHT FINISH)

3.0 MECHANICAL:

- 3.1 SMA INTERFACE PER MIL-STD-348, FIG 310-2.
- 3.2 CAPTURED CENTER CONTACT

4.0 ELECTRICAL SPECIFICATION FOR VSWR:

DC - 18.0 GHz
MAX VSWR: 1.08

5.0 DIMENSIONS IN PARENTHESIS ARE MILLIMETERS.

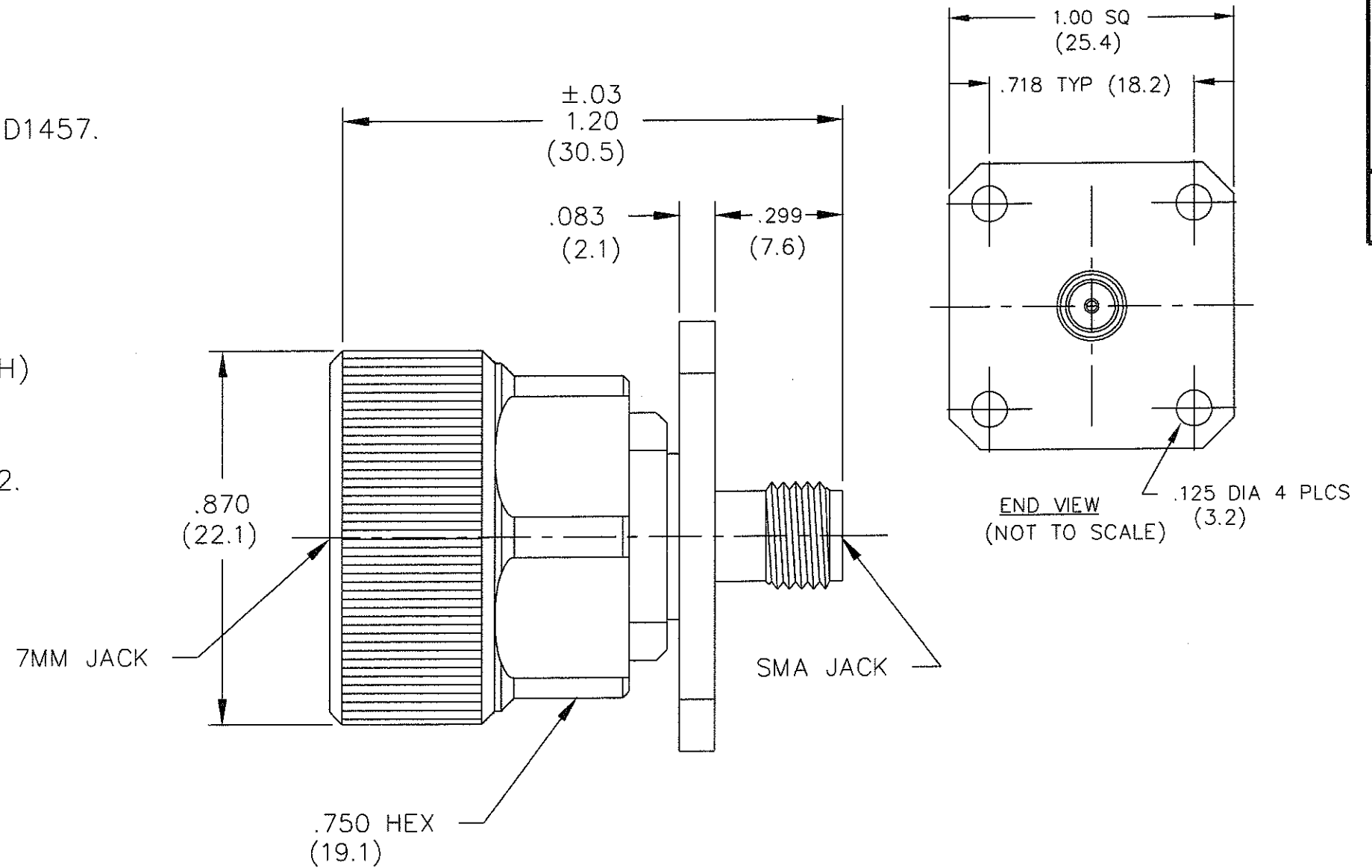

MODEL NUMBER
ADT-2653-7M-SMF-02
REV.
-1

DATE	12/13/91	3/11/05
DESCRIPTION	RELEASED	ADDED TITLEBLOCK
REV.	-	-1

UNLESS OTHERWISE NOTED DIMENSIONS ARE IN INCHES AND TOLERANCES ARE: 3 PLACE DECIMALS ±.005 2 PLACE DECIMALS ±.02 FRACTIONS ±1/64 PARALLELITY: T.I.R. _____ FLATNESS: T.I.R. _____ CONCENTRICITY: T.I.R. _____ ANGLES AND PERPENDICULARITY: ±1'	FSCM NO. 34078	MIDWEST MICROWAVE	
	NOTICE: The information contained in this drawing is proprietary and must not be used without the permission of Midwest Microwave	TITLE ADAPTER 7MM JACK to SMA JACK	
DRAWN/DATE D.SIEWERT 11/19/91	ENG./DATE H.JACQUES 12/12/91	DRAWING NUMBER ADT-2653-7M-SMF-02	
CHECKED/DATE A.OSGA 12/12/01	APPROVED/DATE T.GORDON 12/12/91	SCALE: 3=1	SHEET 1 of 1