

REVISIONS					
P	LTR	DESCRIPTION	DATE	DWN	APVD
H2		REVISED PER ECR-22-160893	15DEC2022	DB	BW

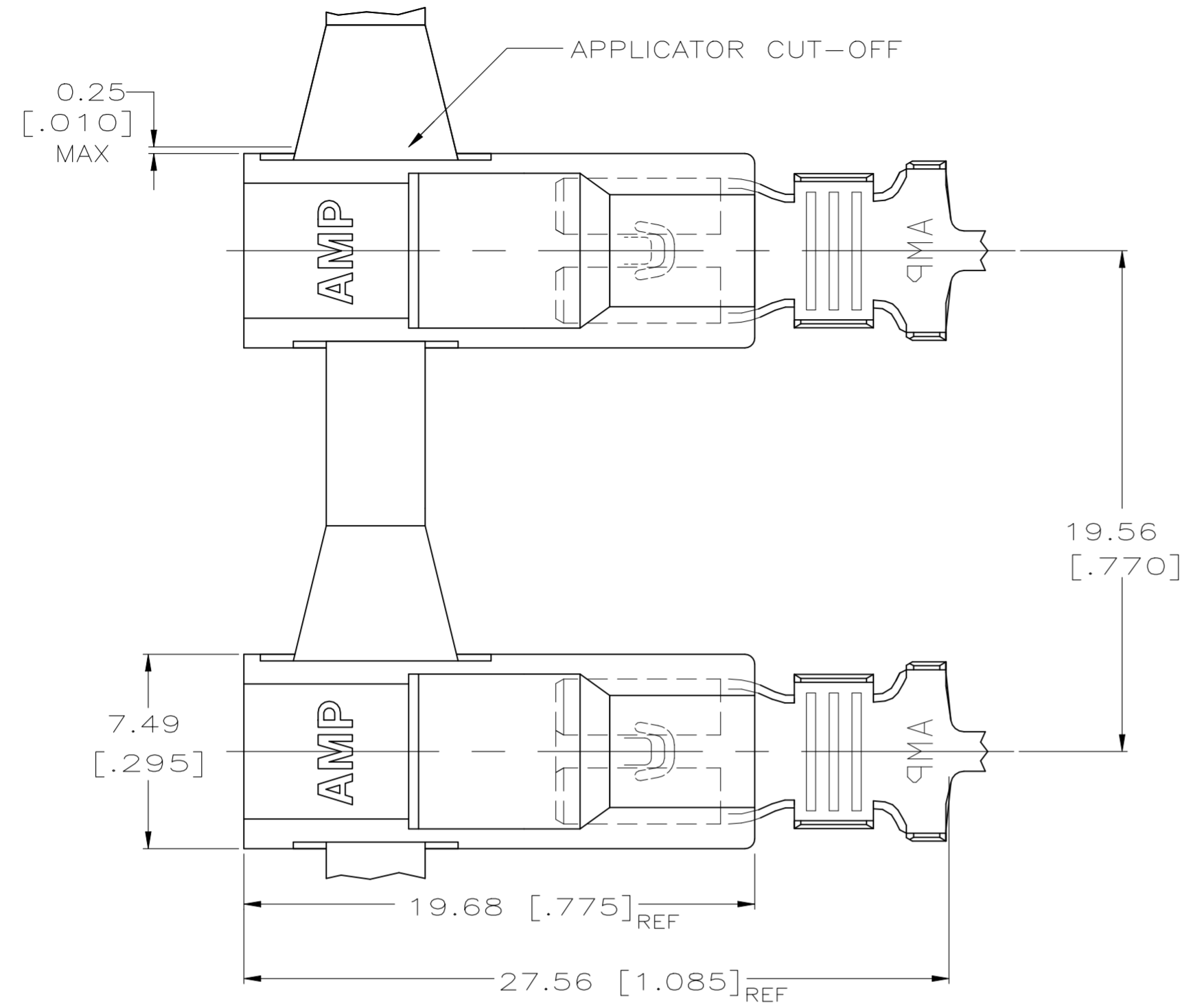

- 1 FASTON TERMINALS, BASE P/N 1742110, ARE USED IN THIS PRODUCT.
- △ 2 TIN PLATE PER MIL-T-10727.
- 3 MATING TAB THK TO BE 0.51±0.025 [.020±.001]
- 4 WIRE SIZE IS [#18-#16 OR TWO #18'S] AWG.
- 5 INSULATION RANGE IS 2.67-5.33 OR TWO AT 2.67 MAX, [.105-.210 OR TWO AT .105 MAX].
- △ 6 OBSOLETE PART

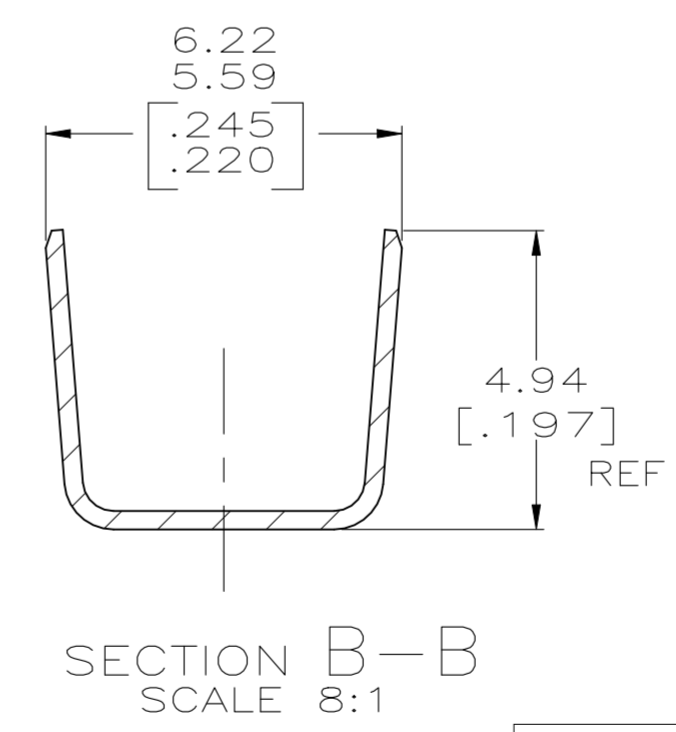
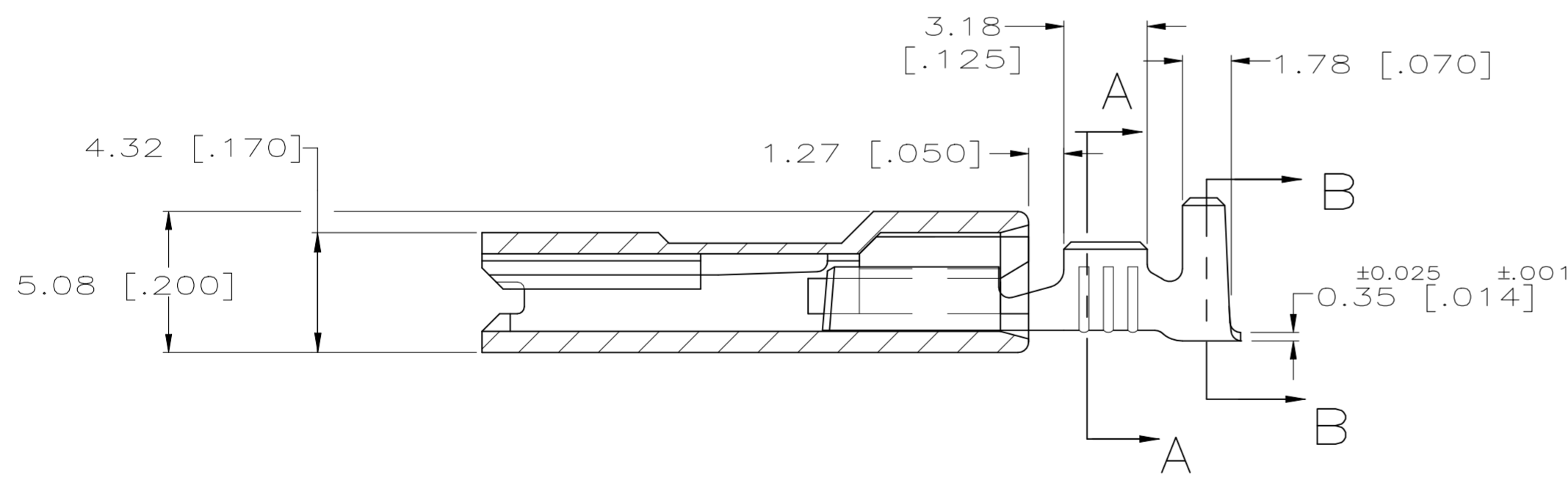
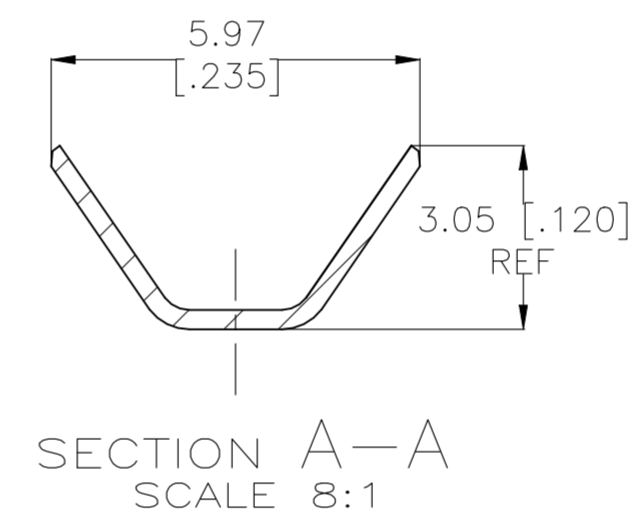

△ 6/6 NYLON, VO - NAT(WHITE)	BRASS - TIN PL △ 2	521586-2
6/6 NYLON, VO - NAT(WHITE)	BRASS - PLAIN	521586-1
HOUSING MATERIAL & COLOR	TERMINAL MATERIAL & FINISH	PART NO

THIS DRAWING IS A CONTROLLED DOCUMENT.		DWN	JR RUTH	17DEC02		ASSEMBLY, RECEPTACLE, ULTRA-POD, 4.8 [.187] SERIES			
DIMENSIONS: mm [INCHES]		CHK	N DEIBERT	17DEC02		NAME			
TOLERANCES UNLESS OTHERWISE SPECIFIED:		APVD	N DEIBERT	17DEC02		PRODUCT SPEC	108-1285		
0 PLC ± -		APPLICATION SPEC		114-2124		SIZE	CAGE CODE	DRAWING NO	RESTRICTED TO
1 PLC ± -		MATERIAL		WEIGHT		A2	00779	C=521586	-
2 PLC ± -		FINISH		CUSTOMER DRAWING		SCALE		SHEET	REV
3 PLC ± 0.25 [.010]		SEE TABLE		SEE TABLE		5:1		1 of 1	H2
4 PLC ± -									
ANGLES ± -									