

THIS DRAWING IS UNPUBLISHED. RELEASED FOR PUBLICATION 20
 © COPYRIGHT 20 BY - ALL RIGHTS RESERVED.

REVISIONS				
P	LTR	DESCRIPTION	DATE	APVD
	C2	REVISED PER ECO-14-009692	7JAN2015	CW SH

HEAT SINK CLIP
 REFERENCE PART NUMBER
 1367646-1

HEAT SINK

CAGE ASSEMBLY
 REFERENCE PART NUMBER
 1367643-1 FOR 1367645-1/2/3
 2227316-1 FOR 1367645-4/5/6

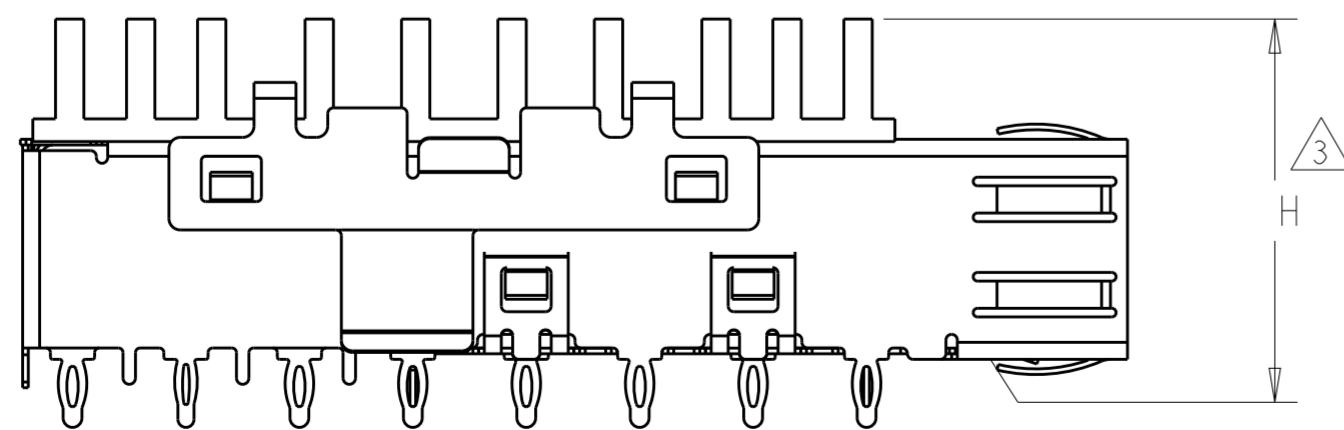
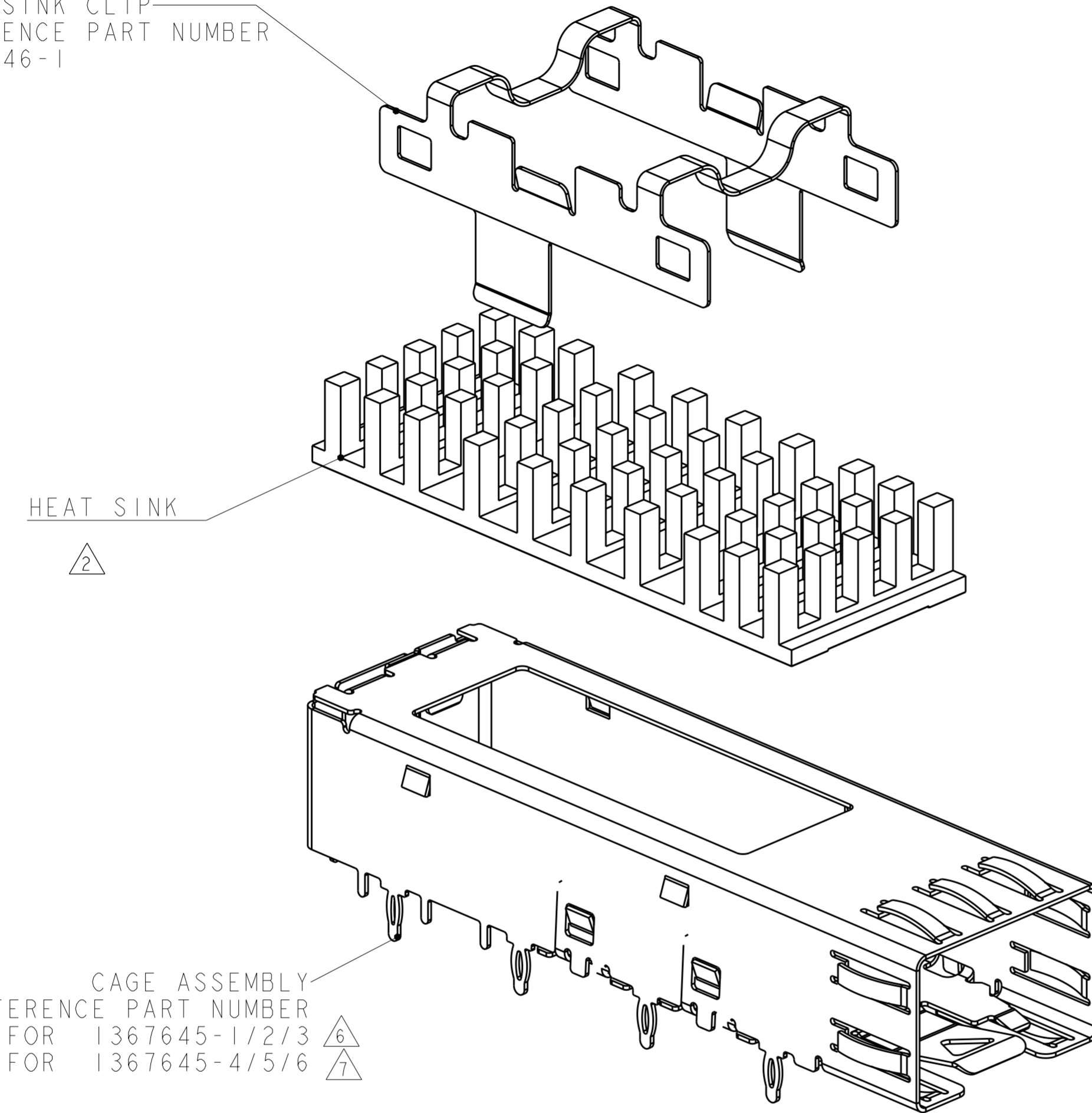

VIEW SHOWN ASSEMBLED
 SCALE 3:1

1. CAGE ASSEMBLY, HEAT SINK CLIP AND HEAT SINK SHIPPED ASSEMBLED.
2. HEAT SINK REFERENCE PART NUMBERS:
 1829903-2 = 4.2 HIGH - PCI
 1829904-2 = 6.5 HIGH - SAN
 1829905-2 = 13.5 HIGH - NETWORKING
3. DIMENSION APPLIES PRIOR TO INSERTION OF SFP MODULE.
4. MATES WITH SFP MSA COMPLIANT TRANSCEIVERS.
5. SEE COMPONENT DRAWINGS FOR COMPONENT DIMENSIONS AND INFORMATION.
6. MATERIAL AND STRUCTURE FOR CAGE ASSEMBLY COPPER ALLOY(TOP CAGE&BOTTOM CAGE 2 PIEPCE STRUCTURE)
7. MATERIAL AND STRUCTURE FOR CAGE ASSEMBLY STAINLESS STEEL(ONE PIECE DESIGN),NICKLE OVER ALL, NON-PLATED EDGES PERMISSIBLE.
8. OBSOLETE

7	22.7 MAX	NETWORKING	1367645-6
7	15.7 MAX	SAN	1367645-5
7	13.4 MAX	PCI	1367645-4
8 6	22.7 MAX	NETWORKING	1367645-3
8 6	15.7 MAX	SAN	1367645-2
8 6	13.4 MAX	PCI	1367645-1
	H	APPLICATION	PART NUMBER

THIS DRAWING IS A CONTROLLED DOCUMENT.		DWN D.E.STAHL 06FEB06	TE Connectivity	
		CHK E.J.BRIGHT 06FEB06		
		APVD E.J.BRIGHT 06FEB06		
DIMENSIONS:	TOLERANCES UNLESS OTHERWISE SPECIFIED:	PRODUCT SPEC	NAME KIT ASSEMBLY, PRESS FIT, DWDM SFP	
mm	0 PLC ± 1 PLC ± 2 PLC ± 3 PLC ± 4 PLC ± ANGLES ± FINISH	108-1950	SIZE A200779	
MATERIAL	-	APPLICATION SPEC 114-13178	DRAWING NO C-1367645	
		WEIGHT -	RESTRICTED TO -	
		Customer Drawing	SCALE 4:1 SHEET 1 OF 1 REV C2	