

17-Bit to 34-Bit, DeMux PCI Hot-Plug Bus Switch with -2V Undershoot Protection

Features

- R_{ON} is 5-ohm typical
- Undershoot protection on A port only: -2V
- Industrial Operation Temperature: -40°C to +85°C
- Near-Zero propagation delay
- Channel On-Capacitance: 15pF max.
- V_{CC} Operating Range: +5V ±10%
- >2kV ESD Protection (human body model)
- >100 MHz switching (enable clock rate) at 20pF load capacitance
- Packaging (Pb-free & Green available):
 - 56-pin plastic TSSOP (A)

Description

The PI5C34171C is a 17 to 34-bit demultiplexer bus switch. It is intended for PCI Hot-Plug applications. Industry leading advantages include a propagation delay of 250ps, resulting from 5-ohm channel resistance, and low I/O Capacitance. A port demultiplexes to either 1B and 2B or to both. The switch is bidirectional. The A port can handle up to -2V undershoot during switch disable.

Application

- Provides PCI Hot Plugging

Block Diagram

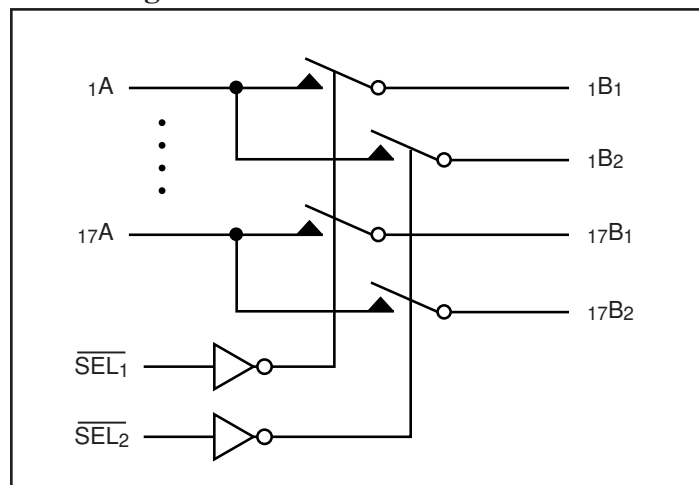

Pin Description

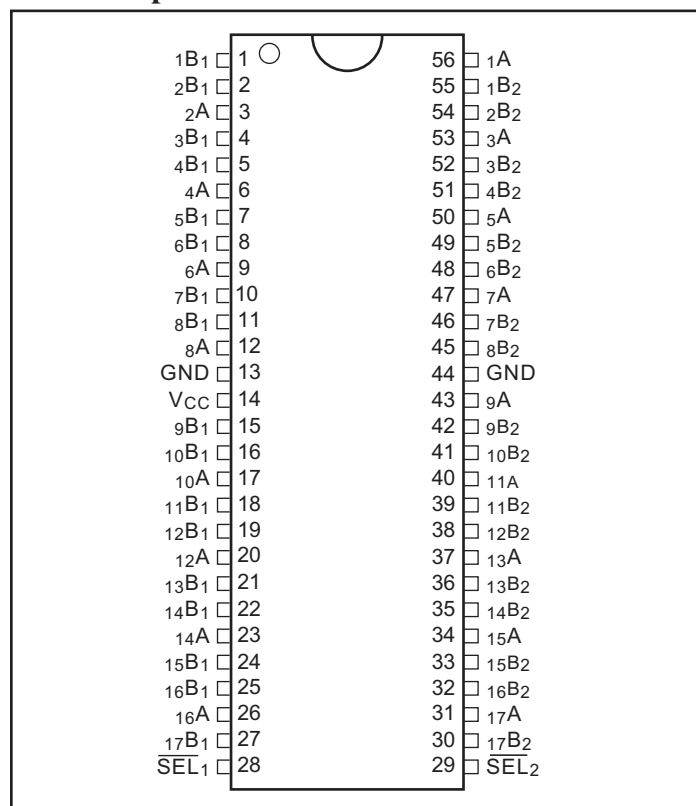

Truth Table

Function	SEL1	SEL2
nA to nB_1	L	H
nA to nB_2	H	L
nA to nB_1 and nB_2	L	L
$nB_1, nB_2 = \text{Hi-Z}$	H	H

Maximum Ratings

(Above which the useful life may be impaired. For user guidelines, not tested.)

Storage Temperature	-65°C to +150°C
Ambient Temperature with Power Applied	-40°C to +85°C
Supply Voltage to Ground Potential (Inputs & V _{CC} Only).....	-0.5V to +7.0V
Supply Voltage to Ground Potential (Outputs & D/O Only) ..	-0.5V to +7.0V
DC Input Voltage	-0.5V to +7.0V
DC Output Current.....	120mA
Power Dissipation	0.5W

Note:

Stresses greater than those listed under MAXIMUM RATINGS may cause permanent damage to the device. This is a stress rating only and functional operation of the device at these or any other conditions above those indicated in the operational sections of this specification is not implied. Exposure to absolute maximum rating conditions for extended periods may affect reliability.

DC Electrical Characteristics (Over the Operating Range, T_A = -40°C to +85°C, V_{CC} = 5V ±10%)

Parameters	Description	Test Conditions ⁽¹⁾	Min.	Typ ⁽²⁾	Max.	Units
V _{IH}	Input HIGH Voltage	Guaranteed Logic HIGH Level	2			V
V _{IL}	Input LOW Voltage	Guaranteed Logic LOW Level	-0.5		0.8	
I _{IH}	Input HIGH Current	V _{CC} = Max., V _{IN} = V _{CC}			±1	μA
I _{IL}	Input LOW Current	V _{CC} = Max., V _{IN} = GND				
I _{OZ}	High Impedance Output Current	0 ≤ A, B ≤ V _{CC}				
V _{IK}	Clamp Diode Voltage	V _{CC} = Min., I _{IN} = -18mA		-0.7	-1.8	V
R _{ON}	Switch On-Resistance ⁽⁴⁾	V _{CC} = Min., V _{IN} = 0.0V, I _{ON} = 48mA		5	8	Ω
		V _{CC} = Min., V _{IN} = 2.4V, I _{ON} = 15mA		10	18	
V _{UP}	Undershoot Protection Voltage ⁽³⁾	Max. Inputs, Undershoot Pulse Duration < 25ns			-2.0	

Notes:

- For Min. or max. conditions, use appropriate value specified under Electrical Characteristics for the applicable device type.
- Typical values are at V_{CC} = 5.0V, T_A = 25°C ambient and maximum loading.
- On A_N (Data Input) pins only.
- Measured by the voltage drop between A and B pins at indicated current through the switch. On-Resistance is determined by the lower of the voltages on the two (A & B) pins.

Capacitance (T_A = 25°C, f = 1 MHz)

Parameters ⁽¹⁾	Description	Test Conditions	Typ.	Max.	Units
C _{IN}	Input Capacitance	V _{IN} = 0V	3.5		pF
C _{OFF(B)}	B Capacitance, Switch Off		4.5		
C _{ON}	A/B Capacitance, Switch On		13.5		

Notes:

- This parameter is determined by device characterization but is not production tested.

Power Supply Characteristics

Parameters	Description	Test Conditions ⁽¹⁾		Min.	Typ. ⁽²⁾	Max.	Units
I _{CC}	Quiescent Power Supply Current	V _{CC} = Max.	V _{IN} = GND or V _{CC}			200	μA
ΔI _{CC}	Supply Current per Input @ TTL HIGH	V _{CC} = Max.	V _{IN} = 3.4V ⁽³⁾ other pin = V _{CC} or GND			2.5	mA
I _{CCD}	Supply Current per Input per MHz ⁽⁴⁾	V _{CC} = Max., A & B Pins Open Control Input Toggling 50% Duty Cycle				0.60	mA/MHz

Notes:

- For Max. or Min. conditions, use appropriate value specified under Electrical Characteristics for the applicable device.
- Typical values are at V_{CC} = 5.0V, +25°C ambient.
- Per TTL driven input (V_{IN} = 3.4V, control inputs only); A and B pins do not contribute to I_{CC}.
- This current applies to the control inputs only and represent the current required to switch internal capacitance at the specified frequency. The A and B inputs generate no significant AC or DC currents as they transition. This parameter is not tested, but is guaranteed by design.

Switching Characteristics over Operating Range

Parameters	Description	Conditions	Com			Units
			Min.	Typ.	Max.	
t _{PLH} t _{PHL}	Propagation Delay ^(1,2) A to B	C _L = 50pF R _L = 500-ohm		0.25		ns
t _{PZH} t _{PZL}	Bus Enable Time SEL to A,B		10		40	
t _{PHZ} t _{PLZ}	Bus Disable Time SEL to A,B		1		6	

Notes:

- This parameter is guaranteed but not tested on Propagation Delays.
- The bus switch contributes no propagational delay other than the RC delay of the On-Resistance of the switch and the load capacitance. The time constant for the switch alone is of the order of 0.25ns for 50pF load. Since this time constant is much smaller than the rise/fall times of typical driving signals, it adds very little propagational delay to the system. Propagational delay of the bus switch when used in a system is determined by the driving circuit on the driving side of the switch and its interaction with the load on the driven side.

Applications Information

Logic Inputs

The logic control inputs can be driven up to +5.5V regardless of the supply voltage. For example, given a +5.0V supply, control inputs may be driven low to 0V and high to 5.5V. Driving control inputs Rail-to-Rail[®] minimizes power consumption.

Power-Supply Sequencing

Proper power-supply sequencing is recommended for all CMOS devices. Always apply V_{CC} before applying signals to the input/output or control pins.

Rail-to-Rail is a registered trademark of Nippon Motorola, Ltd.

Packaging Mechanical: 56-pin TSSOP (A)

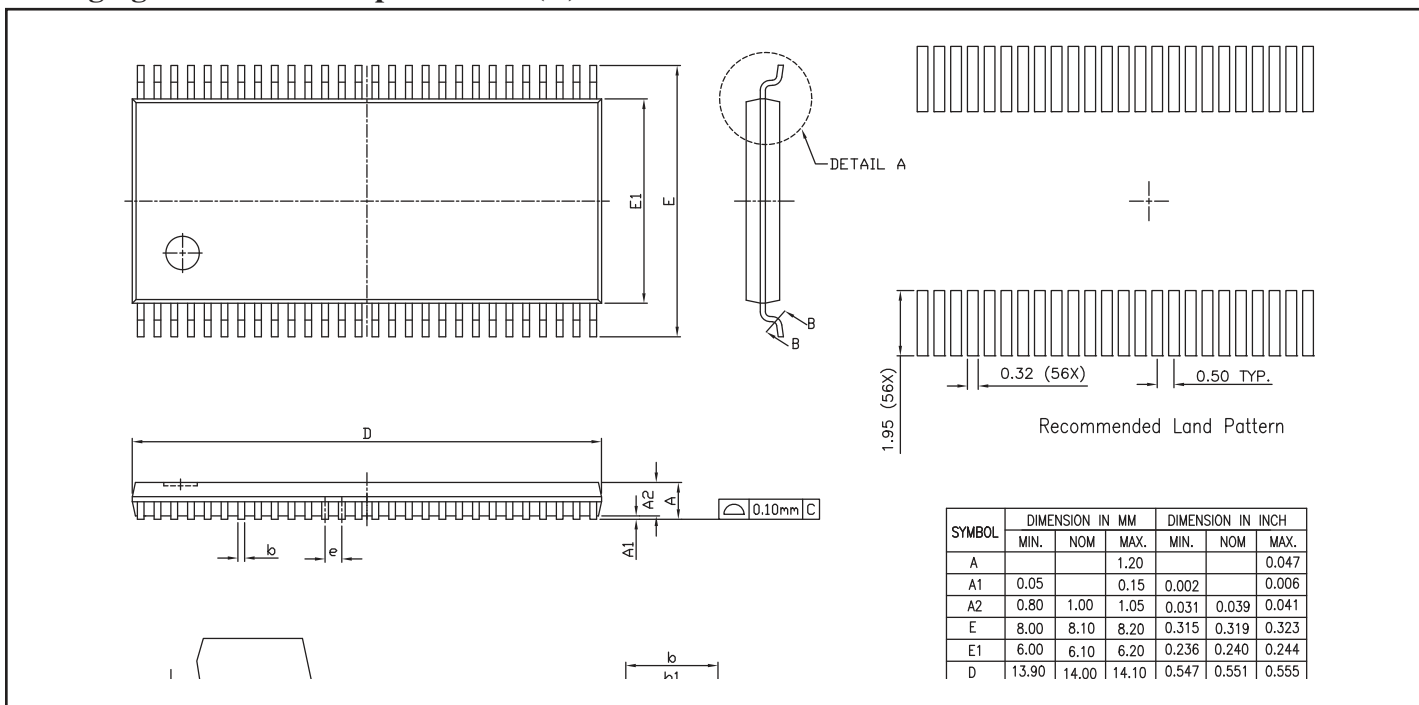

Ordering Information

Ordering Code	Package Code	Package Description
PI5C34171CA	A	56-pin 240-mil plastic TSSOP
PI5C34171CAE	A	Pb-free & Green, 56-pin 240-mil plastic TSSOP

Notes:

- Thermal characteristics can be found on the company web site at www.pericom.com/packaging/
- E = Pb-free & Green
- Adding an X suffix = Tape/Reel