

## High Voltage Single SPDT Analog Switch in SOT23-8

### DESCRIPTION

The DG449 is a dual supply single-pole/double-throw (SPDT) switches. On resistance is  $38\ \Omega$  and flatness is  $2.6\ \Omega$  max over the specified analog signal range. These analog switches were designed to provide high speed, low error switching of precision analog signals. The primary application areas are in the routing and switching in telecommunications and test equipment. Combining low power, low leakages, low on-resistance and small physical size, the DG449 is also ideally suited for portable and battery powered industrial and military equipment.

The DG449 operates either from a single  $+7\ \text{V}$  to  $36\ \text{V}$  supply or from dual  $\pm 4.5\ \text{V}$  to  $\pm 20\ \text{V}$  supplies. It is offered in the very popular, small SOT23-8 package.

### FEATURES

- $\pm 15\ \text{V}$  analog signal range
- On-resistance -  $R_{DS(on)}$ :  $38\ \Omega$  max.
- $V_L$  logic supply not required
- TTL CMOS input compatible
- Rail to rail signal handling
- Dual or single supply operation

**RoHS**  
COMPLIANT

### BENEFITS

- Wide dynamic range
- Low signal errors and distortion
- Break-before-make switching action
- Simple interfacing
- Small SOT23-8 package; reduced board space
- Improved reliability

### APPLICATIONS

- Precision test equipment
- Precision instrumentation
- Communications systems
- PBX, PABX systems
- Audio equipment
- Redundant systems
- PC multimedia boards
- Hard disc drives

### FUNCTIONAL BLOCK DIAGRAM AND PIN CONFIGURATION

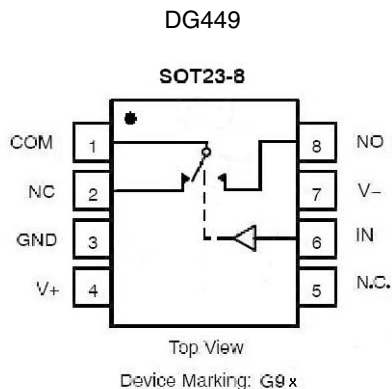

### TRUTH TABLE

Logic	NC	NO
0	ON	OFF
1	OFF	ON

Logic "0"  $\leq 0.8\ \text{V}$   
Logic "1"  $\geq 2.4\ \text{V}$



ORDERING INFORMATION		
Temp. Range	Package	Part Number
- 40 to 85 °C	8-Pin SOT23	DG449DS-T1-E3

ABSOLUTE MAXIMUM RATINGS (T <sub>A</sub> = 25 °C, unless otherwise noted)			
Parameter (Voltages Referenced to V-)	Symbol	Limit	Unit
V+		44	V
GND		25	
Digital Inputs <sup>a</sup> , V <sub>no/nc</sub> , V <sub>COM</sub>		(V-) - 2 V to (V+) + 2 V or 30 mA, whichever occurs first	
Current, (Any Terminal) Continuous		30	mA
Current (NO, NC or COM) Pulsed at 1 ms, 10 % duty cycle		100	
Storage Temperature		- 65 to 150	°C
Power Dissipation (Package) <sup>b</sup>	8-Pin SOT-23 <sup>c</sup>	675	mW

Notes:

- a. Signals on NO, NC, COM, or IN exceeding V+ or V- will be clamped by internal diodes. Limit forward diode current to maximum current ratings.
- b. All leads welded or soldered to PC board.
- c. Derate 8.4 mW/°C above 70 °C.



SPECIFICATIONS <sup>a</sup>							
Parameter	Symbol	Test Conditions Unless Otherwise Specified V <sub>+</sub> = 15 V, V <sub>-</sub> = - 15 V V <sub>IN</sub> = 2.4 V, 0.8 V <sup>f</sup>	Temp. <sup>b</sup>	D Suffix - 40 °C to 85 °C			Unit
				Min. <sup>d</sup>	Typ. <sup>c</sup>	Max. <sup>d</sup>	
<b>Analog Switch</b>							
Analog Signal Range <sup>e</sup>	V <sub>ANALOG</sub>		Full	- 15		15	V
On-Resistance	R <sub>ON</sub>	I <sub>no/nc</sub> = 1 mA, V <sub>COM</sub> = ± 8.5 V V <sub>+</sub> = 13.5 V, V <sub>-</sub> = - 13.5 V	Room		38	45	Ω
On Resistance MATCH	ΔR <sub>ON</sub>		Full			5	
On-Resistance Flatness	R <sub>ON</sub> Flatness	I <sub>no/nc</sub> = 1 mA, V <sub>COM</sub> = ± 5 V, 0 V V <sub>+</sub> = 13.5 V, V <sub>-</sub> = - 13.5 V	Room		2.6	7	Ω
			Full			8	
Switch Off Leakage Current	I <sub>no/nc(off)</sub>	V <sub>+</sub> = 16.5 V, V <sub>-</sub> = - 16.5 V V <sub>COM</sub> = ± 15.5 V V <sub>no/nc</sub> = -/+ 15.5 V	Room	- 1	- 0.1	1	nA
	I <sub>COM(off)</sub>		Full	- 10	- 0.1	10	
Channel On Leakage Current	I <sub>COM(on)</sub>	V <sub>+</sub> = 16.5 V, V <sub>-</sub> = - 16.5 V V <sub>COM</sub> = V <sub>no/nc</sub> = ± 15.5 V	Room	- 2	- 0.1	2	nA
			Full	- 20	- 0.1	20	
<b>Digital Control</b>							
Input, High Voltage	I <sub>INH</sub>		Full	2.4			V
Input, Low Voltage	I <sub>INL</sub>		Full			0.8	
Input Capacitance <sup>e</sup>	C <sub>IN</sub>		Room		4		pF
Input Current V <sub>IN</sub> High or Low	I <sub>IN</sub>	V <sub>IN</sub> = 0 or 5 V		- 1		1	μA
<b>Dynamic Characteristics</b>							
Turn-On Time	t <sub>ON</sub>	R <sub>L</sub> = 300 Ω, C <sub>L</sub> = 35 pF V <sub>no/nc</sub> = ± 10 V	Room		107	146	ns
			Full			155	
Turn-Off Time	t <sub>OFF</sub>		Room		69	104	ns
			Full			116	
Charge Injection <sup>e</sup>	Q	C <sub>L</sub> = 1 nF, V <sub>gen</sub> = 0 V, R <sub>gen</sub> = 0 Ω	Room		5		pC
Off-Isolation <sup>e</sup>	OIRR	R <sub>L</sub> = 50 Ω, C <sub>L</sub> = 5 pF, f = 1 MHz	Room		- 69		dB
Crosstalk <sup>e</sup>	X <sub>TALK</sub>	R <sub>L</sub> = 50 Ω, C <sub>L</sub> = 5 pF, f = 1 MHz			- 80		
Source NO, NC Off Capacitance <sup>e</sup>	C <sub>no/nc(off)</sub>	f = 1 MHz	Room		8		pF
Channel On Capacitance <sup>e</sup>	C <sub>COM(on)</sub>	f = 1 MHz	Room		18		
<b>Power Supplies</b>							
Positive Supply Current	I <sub>+</sub>	V <sub>+</sub> = 16.5 V, V <sub>-</sub> = - 16.5 V V <sub>IN</sub> = 0, 5 V or, V <sub>+</sub>	Room		4	20	μA
			Full			30	
Negative Supply Current	I <sub>-</sub>		Room	- 1			μA
			Full	- 3			



SPECIFICATIONS <sup>a</sup>							
Parameter	Symbol	Test Conditions Unless Otherwise Specified V <sub>+</sub> = 12 V, V <sub>-</sub> = 0 V V <sub>IN</sub> = 2.4 V, 0.8 V <sup>f</sup>	Temp. <sup>b</sup>	D Suffix - 40 °C to 85 °C			Unit
				Min. <sup>d</sup>	Typ. <sup>c</sup>	Max. <sup>d</sup>	
<b>Analog Switch</b>							
Analog Signal Range <sup>e</sup>	V <sub>ANALOG</sub>		Full	0		12	V
On-Resistance	R <sub>ON</sub>	I <sub>no/nc</sub> = 1 mA, V <sub>COM</sub> = 3, 8 V V <sub>+</sub> = 10.8 V	Room		67	85	Ω
On-Resistance MATCH	ΔR <sub>ON</sub>		Full			4	
On-Resistance Flatness	R <sub>ON</sub> Flatness	I <sub>no/nc</sub> = 1 mA, V <sub>COM</sub> = 2, 6, 10 V V <sub>+</sub> = 10.8 V	Room		17	25	
			Full			31	
<b>Dynamic Characteristics</b>							
Turn-On Time	t <sub>ON</sub>	V <sub>NO, NC</sub> = 10 V, R <sub>L</sub> = 300 Ω, C <sub>L</sub> = 35 pF	Room		133	168	nS
Turn-Off Time	t <sub>OFF</sub>		Full		58	92	
Charge Injection <sup>e</sup>	Q	C <sub>L</sub> = 1 nF, V <sub>gen</sub> = 0 V, R <sub>gen</sub> = 0 Ω	Room		6		pC
<b>Power Supplies</b>							
Positive Supply Current	I <sub>+</sub>	V <sub>+</sub> = 13.2 V, V <sub>IN</sub> = 0 V, 5 V or V <sub>+</sub>	Room		3	20	μA
			Full			30	

Notes:

- a. Refer to PROCESS OPTION FLOWCHART .
- b. Room = 25 °C, Full = as determined by the operating temperature suffix.
- c. Typical values are for DESIGN AID ONLY, not guaranteed nor subject to production testing.
- d. The algebraic convention whereby the most negative value is a minimum and the most positive a maximum, is used in this data sheet.
- e. Guaranteed by design, not subject to production test.
- f. V<sub>IN</sub> = input voltage to perform proper function.

Stresses beyond those listed under "Absolute Maximum Ratings" may cause permanent damage to the device. These are stress ratings only, and functional operation of the device at these or any other conditions beyond those indicated in the operational sections of the specifications is not implied. Exposure to absolute maximum rating conditions for extended periods may affect device reliability.

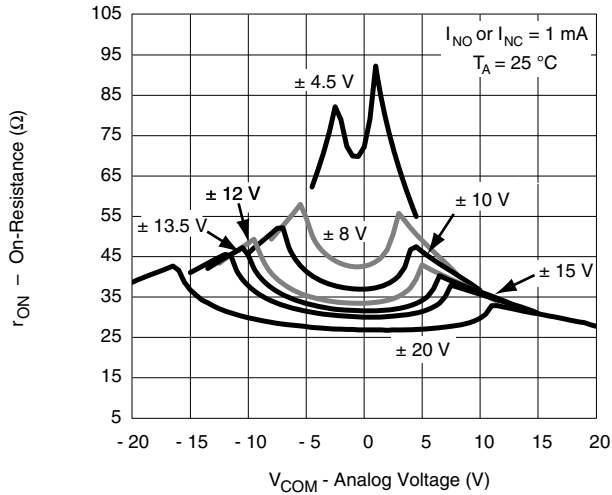
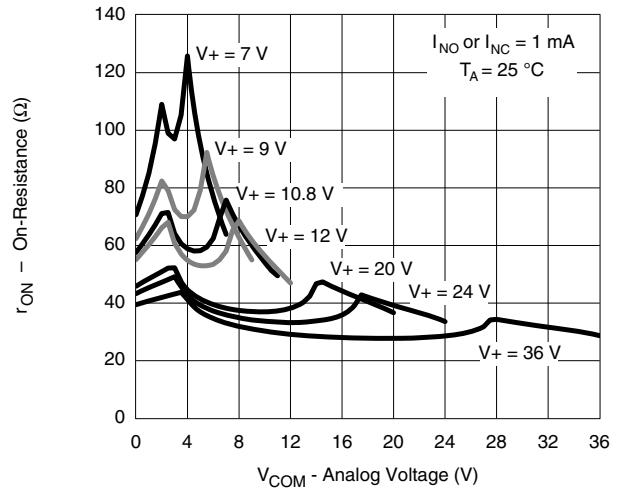
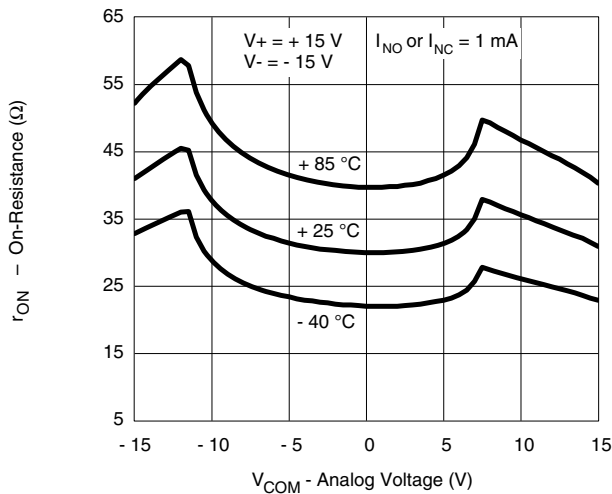
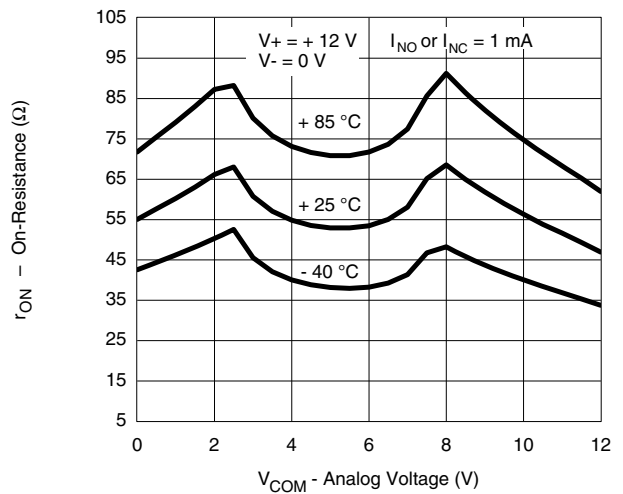
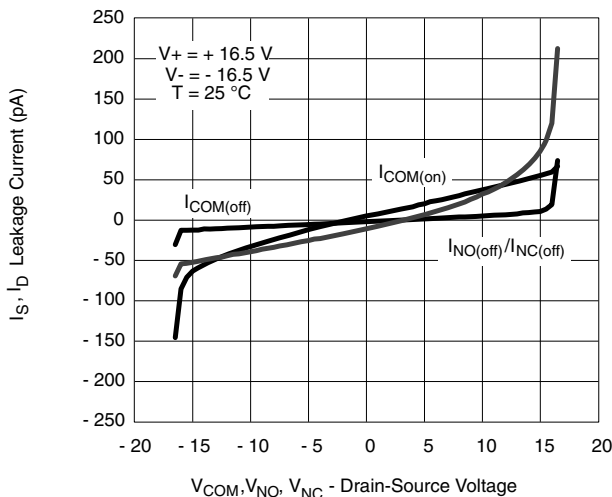
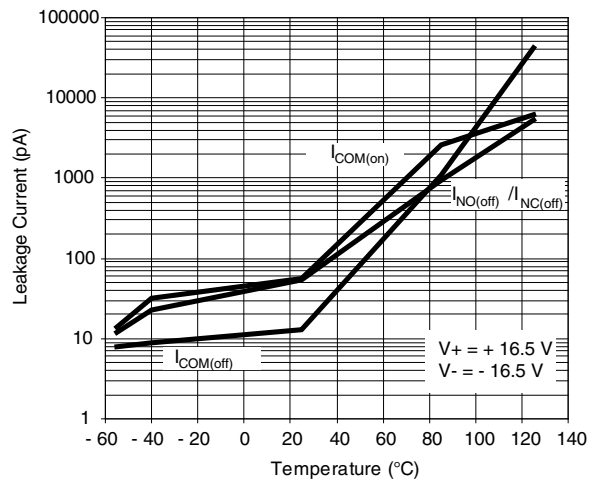
**TYPICAL CHARACTERISTICS** ( $T_A = 25^\circ\text{C}$ , unless otherwise noted)

 **$r_{ON}$  vs.  $V_{COM}$  and Dual Supply Voltage**

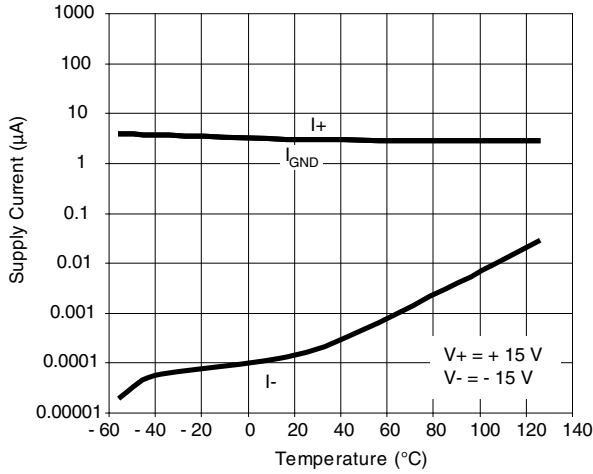
**On Resistance vs.  $V_{COM}$  and Single Supply Voltage**

**On Resistance vs.  $V_{COM}$  and Temperature**

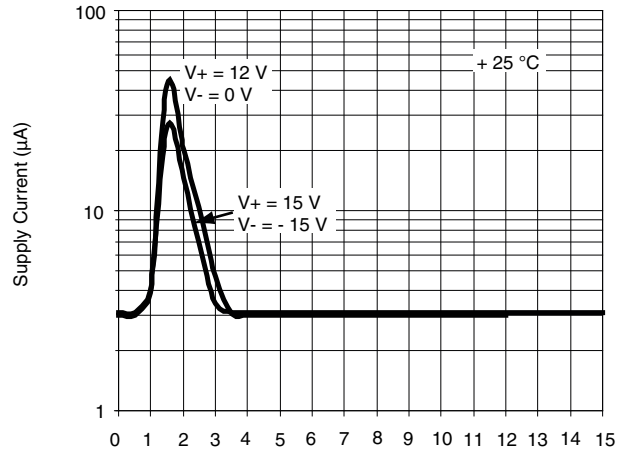
**On Resistance vs.  $V_{COM}$  and Temperature**

**Leakage Current vs. Analog Voltage**

**Leakage Current vs. Temperature**

**TYPICAL CHARACTERISTICS** ( $T_A = 25\text{ }^\circ\text{C}$ , unless otherwise noted)



**Supply Current vs. Temperature**



**Supply Current vs. Input Voltage**

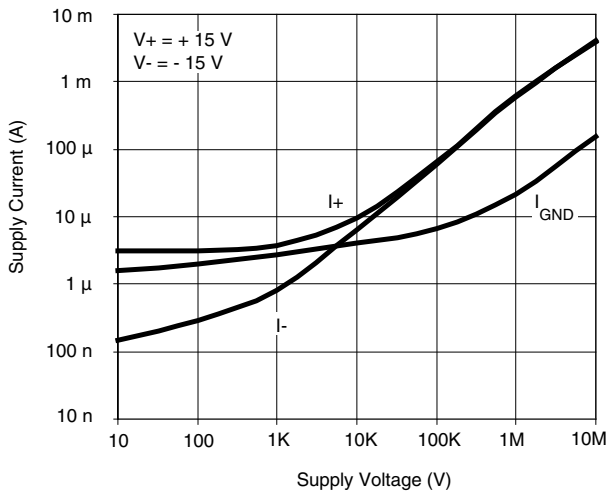

**Supply Current vs. Input Switching Frequency**

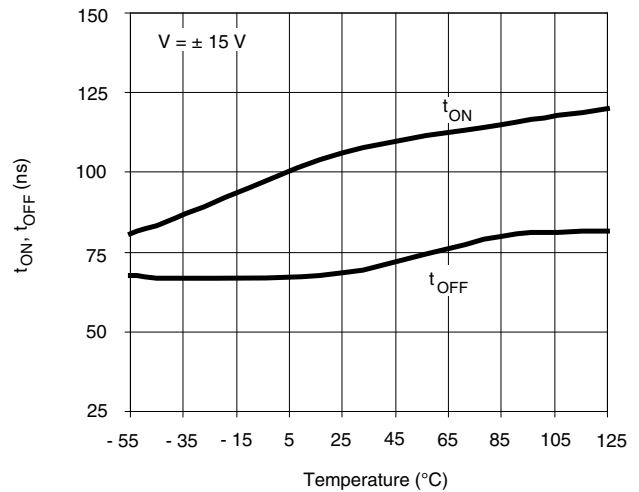

**Switching Time vs. Temperature and Single Supply Voltage**

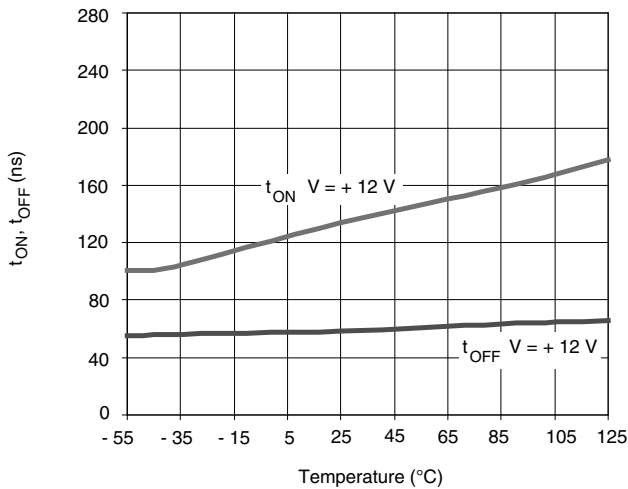

**Switching Time vs. Temperature and Single Supply Voltage**

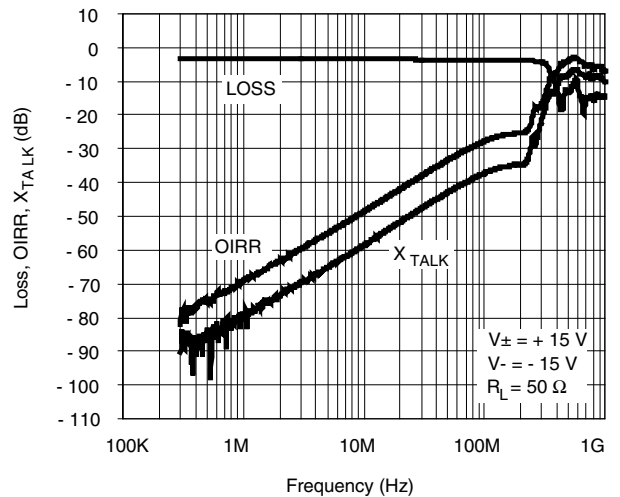

**Insertion Loss, Off-Isolation, Crosstalk vs. Frequency**

**TYPICAL CHARACTERISTICS** ( $T_A = 25\text{ }^\circ\text{C}$ , unless otherwise noted)

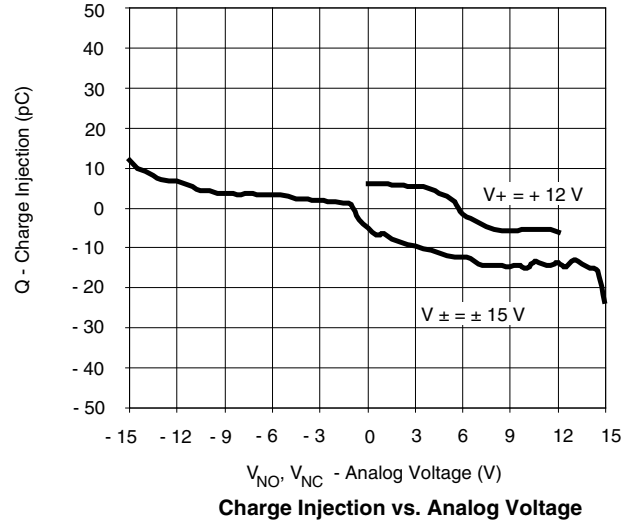
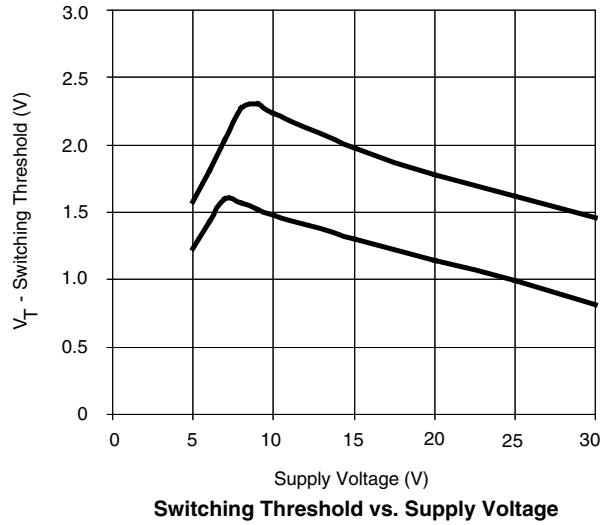

**TEST CIRCUITS**

$V_O$  is the steady state output with the switch on.

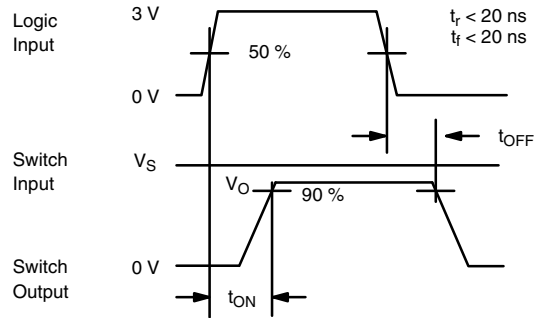
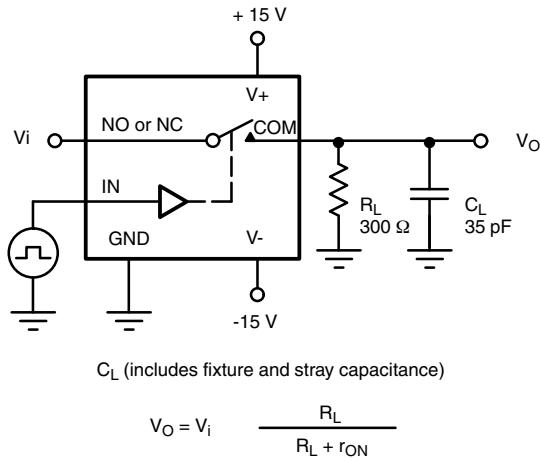

Note: Logic input waveform is inverted for switches that have the opposite logic sense.

**Figure 1. Switching Time**

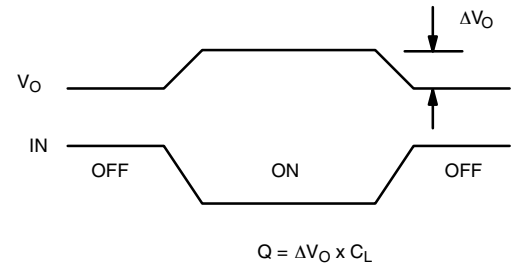
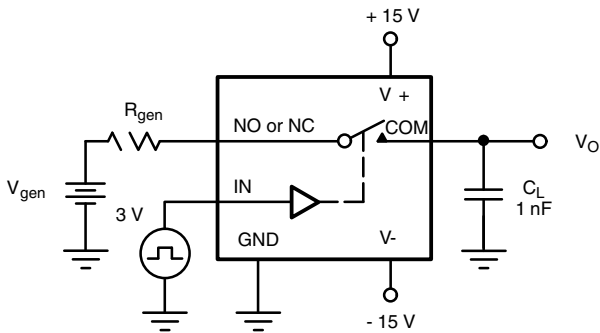

**Figure 2. Charge Injection**

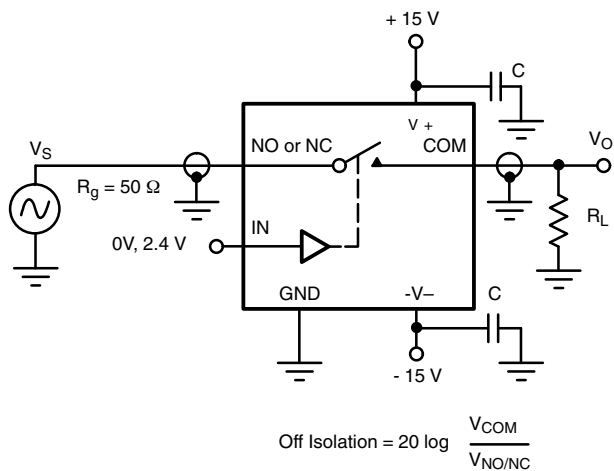

Figure 3. Off Isolation

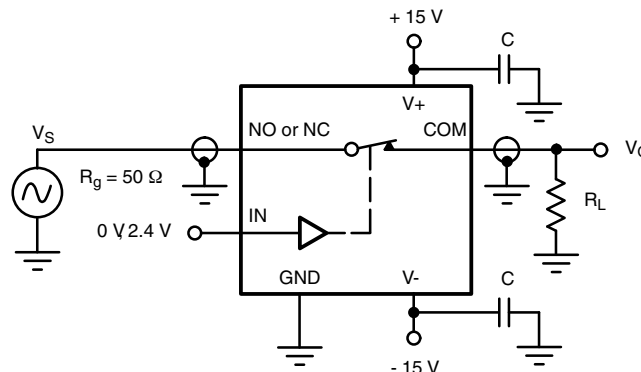

Figure 4. Insertion Loss

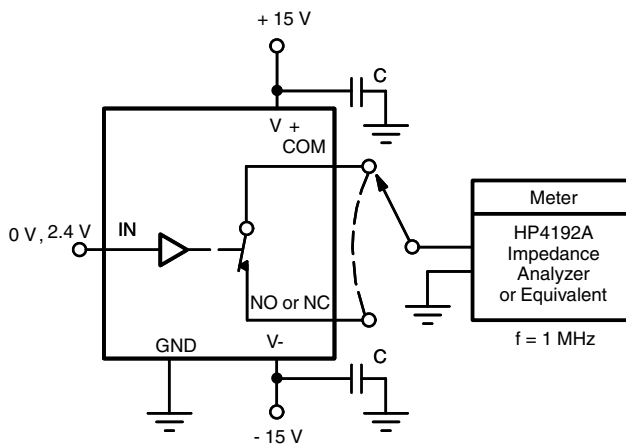
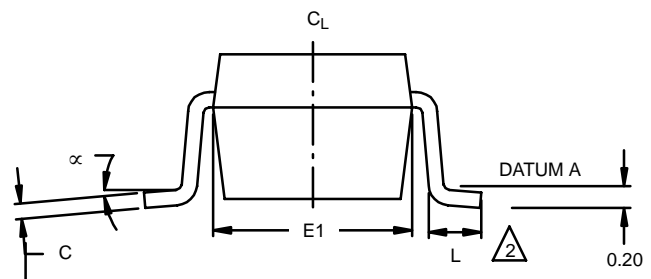
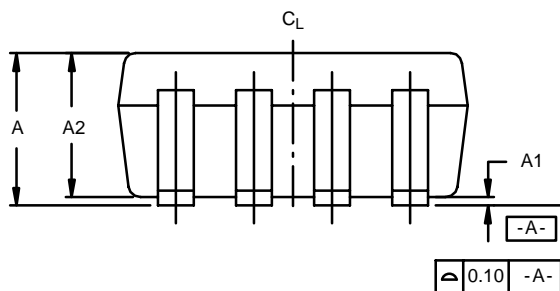
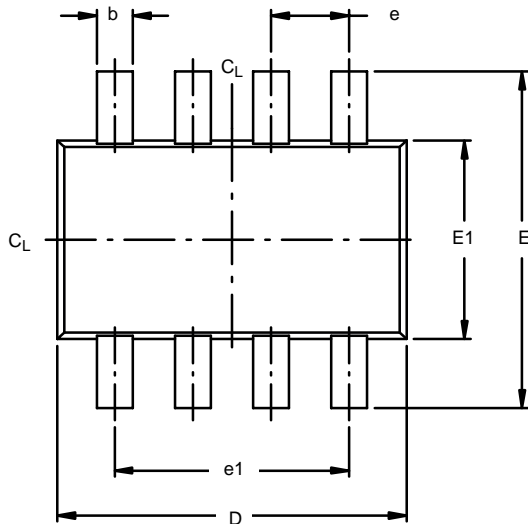

Figure 5. Channel ON/OFF Capacitances

Vishay Siliconix maintains worldwide manufacturing capability. Products may be manufactured at one of several qualified locations. Reliability data for Silicon Technology and Package Reliability represent a composite of all qualified locations. For related documents such as package/tape drawings, part marking, and reliability data, see [www.vishay.com/ppg?73897](http://www.vishay.com/ppg?73897).



### SOT-23 : 8-LEAD



**NOTES:**

1. All dimensions are in millimeters.
2. Foot length measured at intercept point between Datum A and lead surface.
3. Package outline exclusive of mold flash and metal burr.
4. Package outline inclusive of solder plating.
5. No molding flash allowed on the top and bottom lead surface.

Dim	MILLIMETERS			INCHES		
	Min	Nom	Max	Min	Nom	Max
<b>A</b>	0.90	1.27	1.45	0.035	0.05	0.057
<b>A1</b>	0.00	0.0762	0.15	0.000	0.003	0.006
<b>A2</b>	0.90	1.20	1.30	0.035	0.047	0.051
<b>b</b>	0.22	0.30	0.38	0.009	0.012	0.015
<b>C</b>	0.09	0.152	0.20	0.004	0.006	0.008
<b>D</b>	2.80	2.9	3.00	0.11	0.114	0.118
<b>E</b>	2.60	2.8	23.00	0.102	0.11	0.118
<b>E1</b>	1.50	1.65	1.75	0.059	0.065	0.069
<b>e</b>	0.65 REF			0.026 REF		
<b>e1</b>	1.95 REF			0.077 REF		
<b>L</b>	0.35	0.45	0.55	0.014	0.018	0.022
$\alpha$	0°	4°	8°	0°	4°	8°

ECN: C-03085—Rev. A, 07-Apr-03  
DWG: 5895



## **Disclaimer**

ALL PRODUCT, PRODUCT SPECIFICATIONS AND DATA ARE SUBJECT TO CHANGE WITHOUT NOTICE TO IMPROVE RELIABILITY, FUNCTION OR DESIGN OR OTHERWISE.

Vishay Intertechnology, Inc., its affiliates, agents, and employees, and all persons acting on its or their behalf (collectively, "Vishay"), disclaim any and all liability for any errors, inaccuracies or incompleteness contained in any datasheet or in any other disclosure relating to any product.

Vishay makes no warranty, representation or guarantee regarding the suitability of the products for any particular purpose or the continuing production of any product. To the maximum extent permitted by applicable law, Vishay disclaims (i) any and all liability arising out of the application or use of any product, (ii) any and all liability, including without limitation special, consequential or incidental damages, and (iii) any and all implied warranties, including warranties of fitness for particular purpose, non-infringement and merchantability.

Statements regarding the suitability of products for certain types of applications are based on Vishay's knowledge of typical requirements that are often placed on Vishay products in generic applications. Such statements are not binding statements about the suitability of products for a particular application. It is the customer's responsibility to validate that a particular product with the properties described in the product specification is suitable for use in a particular application. Parameters provided in datasheets and / or specifications may vary in different applications and performance may vary over time. All operating parameters, including typical parameters, must be validated for each customer application by the customer's technical experts. Product specifications do not expand or otherwise modify Vishay's terms and conditions of purchase, including but not limited to the warranty expressed therein.

Except as expressly indicated in writing, Vishay products are not designed for use in medical, life-saving, or life-sustaining applications or for any other application in which the failure of the Vishay product could result in personal injury or death. Customers using or selling Vishay products not expressly indicated for use in such applications do so at their own risk. Please contact authorized Vishay personnel to obtain written terms and conditions regarding products designed for such applications.

No license, express or implied, by estoppel or otherwise, to any intellectual property rights is granted by this document or by any conduct of Vishay. Product names and markings noted herein may be trademarks of their respective owners.