

General

Ver 1.2

T-200 series is the world's smallest CO₂ sensor module. Its Persistent Stability and Temperature Effect Resistance besides easy management are much favored by customers in stocks raising, greenhouse, scientific projects, etc.

ELT Sensor Data Sheet for T-200

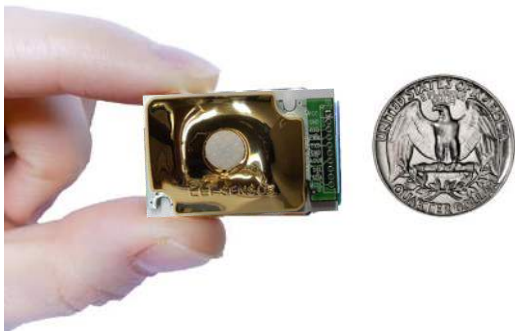

Features

- Non-Dispersive Infrared (NDIR) technology used to measure CO₂ levels.
- The world's smallest size
- Pre-calibrated
- Available output : TTL-UART, I2C
(PWM/Analog Voltage option)
- Gold-plated sensor provides long-term calibration stability.
- Installed Calibration function
- ACDL (Periodical Automatic Calibration) and MCDL (Non-Periodical Manual Calibration) are available..
- Size : 19.4mmx30mmx10.3mm
- Weight : 5 grams

T-200 Specifications

General Performance

Operating Temperature : -20 °C ~ 60 °C

Operating Humidity : 0 ~ 95% RH (Non-condensing)

Operating Environment : Residential, Commercial spaces

Storage Temperature : -30 °C ~ 70 °C

CO₂ Measurement

Sensing Method : NDIR (Non-dispersive Infrared)

Measurement Range : 400 ~ 2,000 (3,000/5,000/10,000ppm, 2%/3%/5%/10% models are available)

Accuracy : ± 50ppm ± 3% of reading ⁽¹⁾ (±300ppm ±3% of reading - 2%/3%/5%/10% models)

Response Time(1/e) : 40 seconds (c.f. T₉₀ : 65 seconds)

Signal Update : 3 seconds

Warming-up Time : < 6 seconds (for Operation), 5 minutes (for Accuracy)

Electrical Data

Power Input : 5.0VDC ± 5%⁽²⁾

Current Consumption: Normal mode : 22mA, Peak : 250 mA

Product Derivatives with Functions

Products	Option List
T-200	UART, I2C, AVO/PWM option, 10'MCDL, ACDL
T-200L	Sleep mode is added which consume < 0.5mA
T-200G (99% Humidity)	Resistance up to 99% Humidity is added for Application of bathroom
T-200A	Operate as ACDL always as software unless 10' MCDL is on,

Pin Map of J1 Side hole.

Pin No.	T-200	T-200 (AVO or PWM Option)
---------	-------	---------------------------

⁽¹⁾ IAQ application, accuracy is defined after minimum 3 times calibration for 3 weeks.

⁽²⁾ DC Supply should be regulated, low noise power source for best accuracy.,

1	VDD (+5V VCC)	
2	GND	
3	TTL-RXD(← CPU of Master Board)	
4	Reserved	PWM (Pulse Width Modulation) (Option)
5	TTL-TXD(→ CPU of Master Board)	
6	ACDL(Automatic Calibration)	
7	Reserved	Analog Voltage Output (Option)
8	I2C SCL	
9	I2C SDA	
10	MCDL(10 min. Manual Calibration)	

※ J1 Side Hole : 1.27mm pitch

UART

38,400BPS, 8bit, No parity, 1 stop bit, TTL Level Voltage

I2C

Slave mode only, 10kΩ pull up resister

TTL Level Voltage : $0 \leq V_{IL} \leq 0.8$, $2 \leq V_{IH} \leq V_{DD}$, $0 \leq V_{OL} \leq 0.4$, $2.4 \leq V_{OH} \leq V_{DD}$ (Volt)

Analog Voltage (0.5~4.5V) : Option

$CO_2 \text{ Measurement}_{(ppm)} = \text{Output Voltage} - 0.5 / (3.0 - 0.5)_{\text{Voltage}} \times \text{F.S.}_{ppm}$,

Digital to Analog Conversion Error : < 0.5%

PWM Output : Option.

$t_H = 2 \text{ msec}(\text{Start}) + 1,000 \text{ msec} \times (\text{Measurement}_{(ppm)} / \text{Range}_{(ppm)})$,

$t_L = 2,000 \text{ ppm} - t_H$, (Period : 2,000 ppm)

Pin Map of J2 Board to Board Connector.

Pin No.	T-200
1/16	VDD (+5V VCC)
2/8/9/12	GND
3	Reset (Active High)
4	Reserved
5	I2C SCL
6	ACDL
7	PWM : Option
10	A-OUT : Option
11	MCDL(10 min. Manual Calibration)
13	TTL-RXD(← CPU of Master Board)
14	TTL-TXD(→ CPU of Master Board)
15	I2C SDA

※ B-to-B Connector mating should be enhanced with additional Locking method.
(T-200 has two of screw type-locking hole - 2Ø U-type hole)

※ T-200 has B-TO-B connecting PLUG (Molex: 55560-0168) on PCB. And mating B-TO-B Receptacle (**Molex: 54722-0164**) should be on Main PCB. Mating Receptacle with PLUG should be done very carefully. Only the gripping of side plane of T-200 is allowed while as pressing on Top plane or Bottom of T-200 is strictly restricted.

Cavity Dimensions (unit : mm)

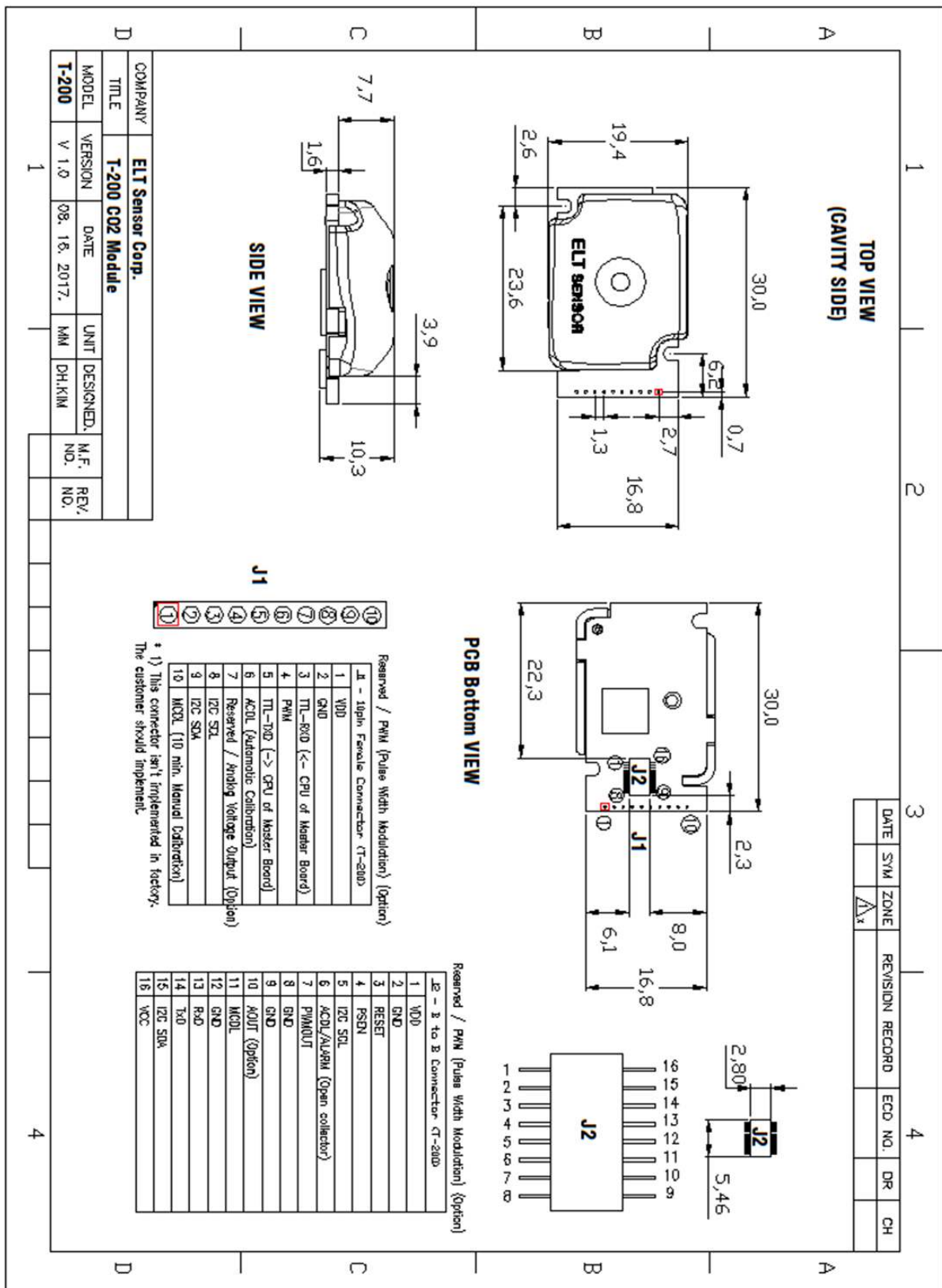

1.27mm pitch socket is recommended for T-200 for convenience of connection.

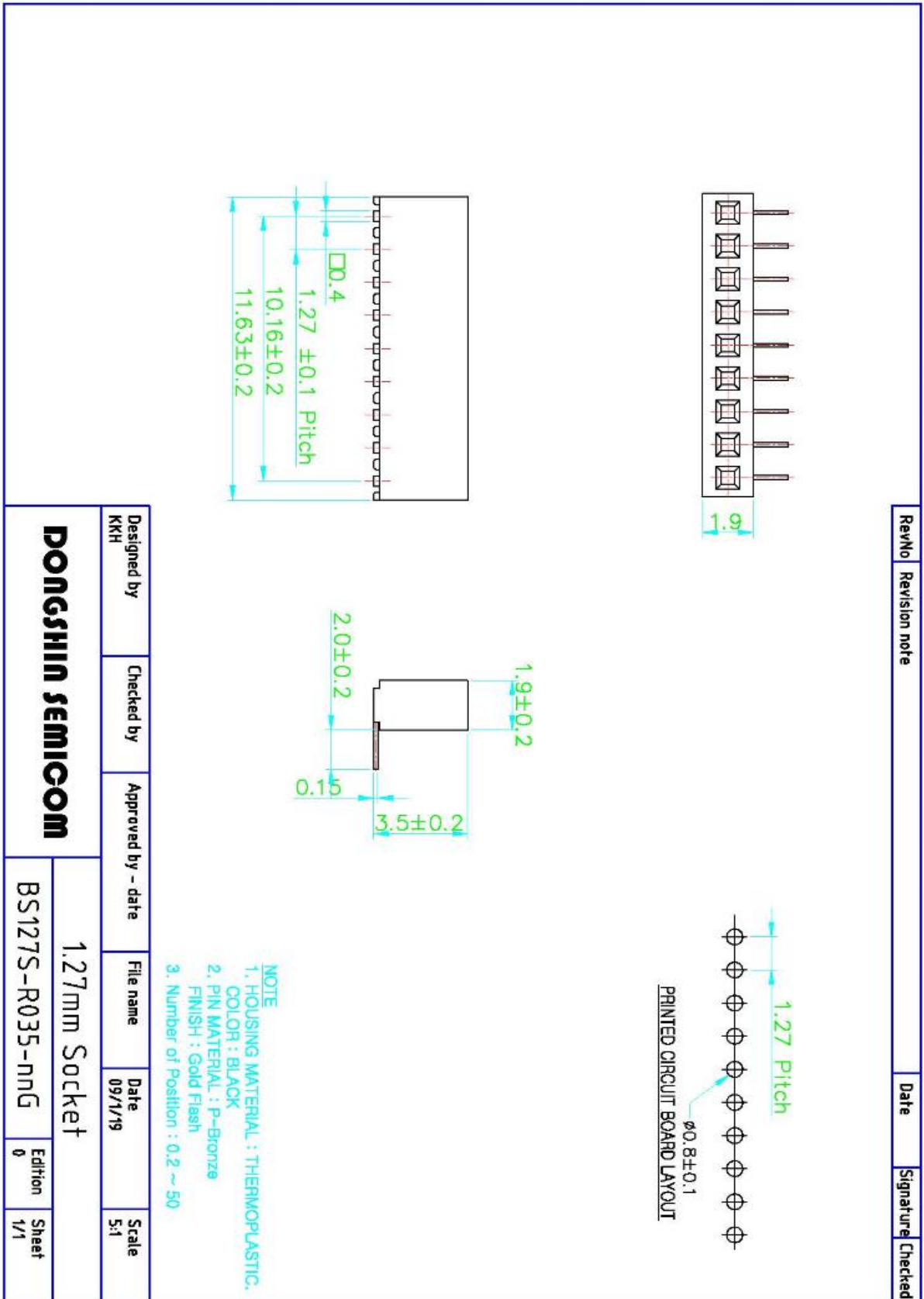

And 1.27mm center pin header recommended for mating with Socket of T-200.

1.27mm Pitch Pin Header(PH15 Series)

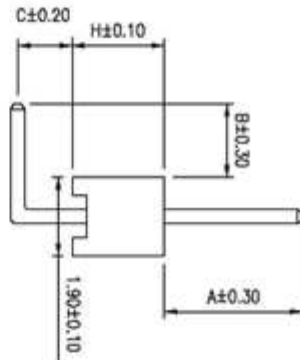
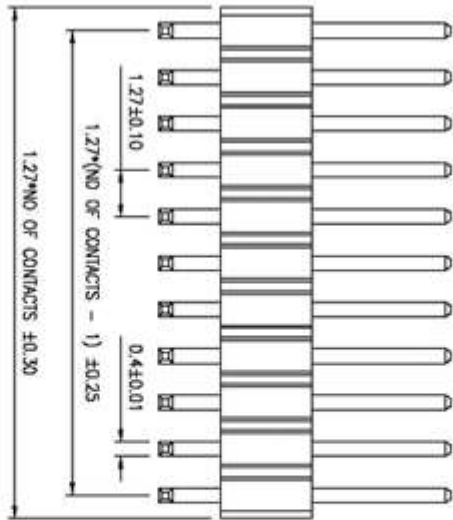

SPECIFICATION

- Current Rating:
1 A
- Withstanding Voltage:
600 VAC (1 min.)
- Insulation Resistance:
1000 Megohms MIN.
- Contact Resistance:
30 Milliohms MAX.
- Operating Temperature:
-40°C to +85°C
- Retention Force:
450g MIN.

MATERIAL

- Contact: Phosphor Bronze ,
0.40mm square post
- Insulator: NYLON 66 & 30% G.F.
- Plating: Selective Gold or Au
Gold

Base Height

Base	H
1	1.00
2	1.50
3	2.00
4	2.40
5	3.00

Pin Chart

Pin	A	B	C
1	2.50	1.50	1.00
2			
3			
4			
5			

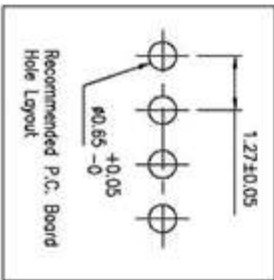

REV	ECN NO.	APP.	DATE
A	NEW DESIGN		

ELEPARTS Co.,Ltd

0.0±	SCALE:	TITLE:	PART NO.:
0.00±	UNIT: MM	1.27MM CENTER PIN HEADER	APP BY:
0.000±		0.40mm/m R/A single Row	CHK BY:
		MATL: NYLON 66 + 30% GF	DR BY:
		DWG. NO. HW02	

T-200 has B-TO-B connecting PLUG (Molex: 55560-0168) on PCB.

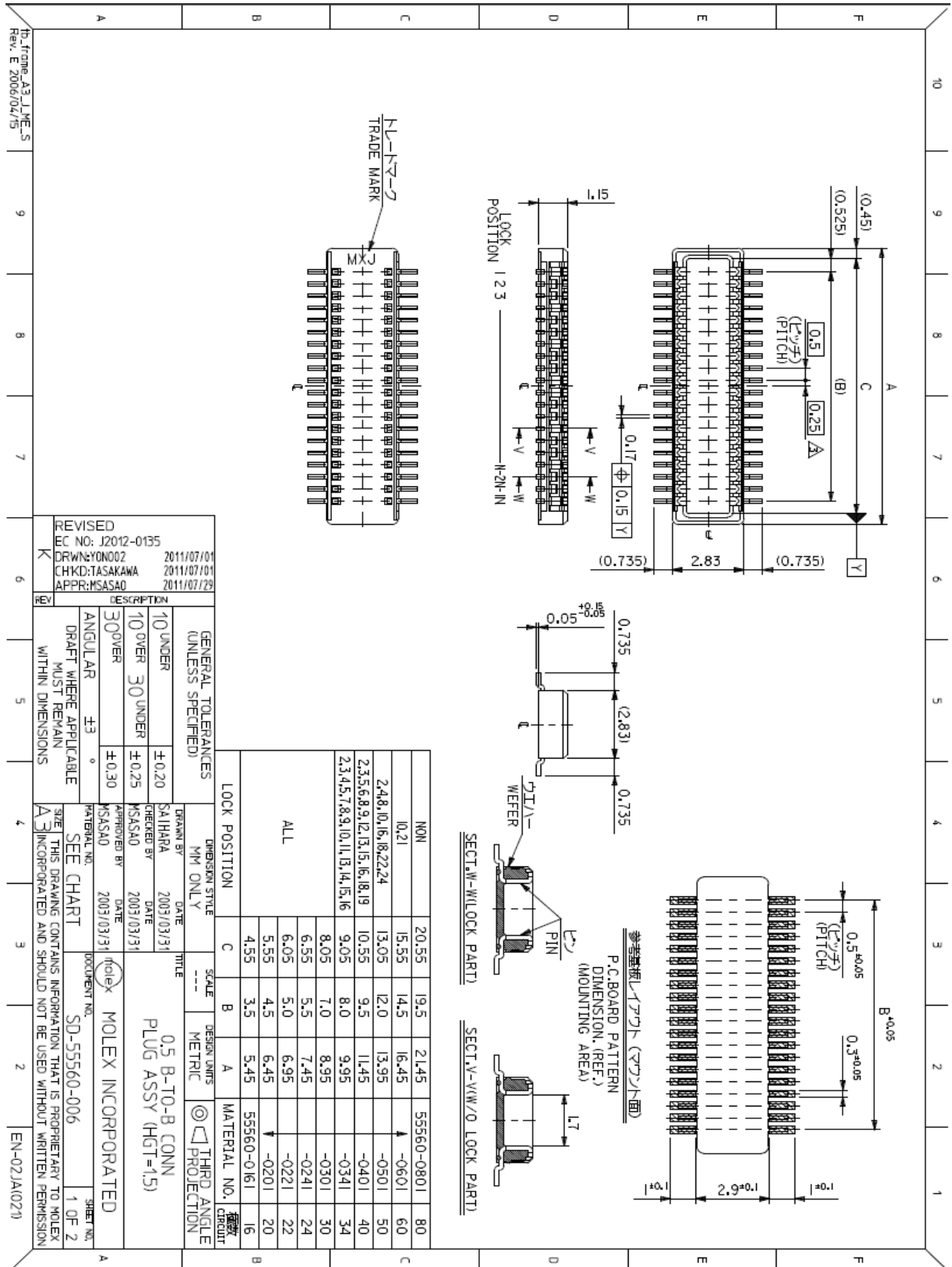

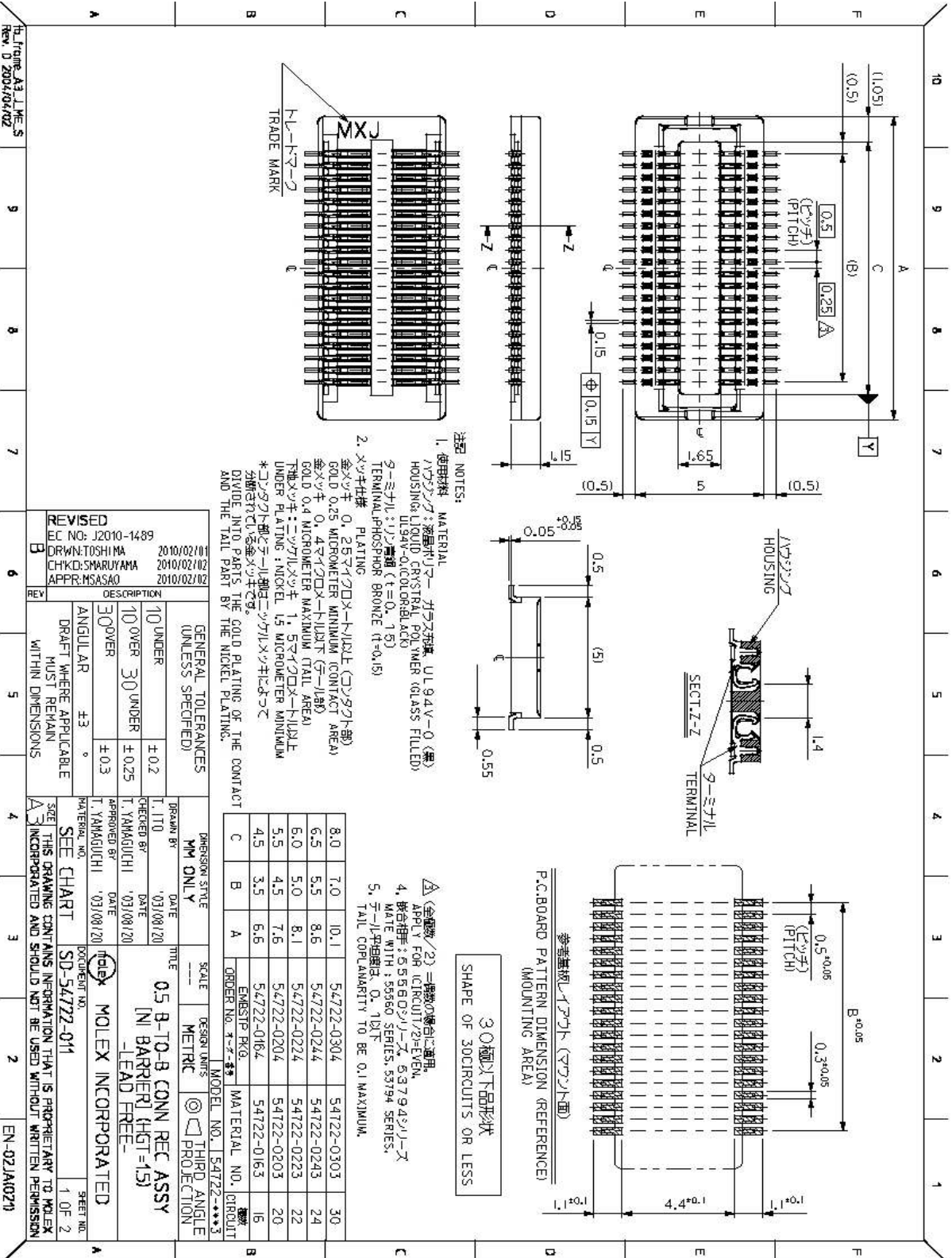

注記 NOTES:

1. 使用材料 MATERIAL
 ケラス基板 UL 94V-0 (黒)
 ハウジング LIQUID CRYSTAL POLYMER (GLASS FILLED)
 UL94V-0(COLOR:BLACK)
 ターミナル: ニッケル (t=0.1μm)
 TERMINAL: NICKEL (t=0.1μm)
 ターミナル: リン青銅 (t=0.15μm)
 TERMINAL: PHOSPHOR BRONZE (t=0.15μm)
2. スリット付 2.5μm以上 (コネクタ部)
 GOLD 0.25 MICROMETER MINIMUM (CONTACT AREA)
 ゴールド 0.25μm以上 (コネクタ部)
 ゴールド 0.4μm以上 (残部)
 残部: ニッケル
 UNDER PLATING: NICKEL 1.5 MICROMETER MINIMUM
 *コネクタ部とターミナル間はニッケルメッキにて
 接続されている場合があります。
 *コネクタ部とターミナル間はニッケルメッキにて
 接続されている場合があります。

SIZE	MODEL NO.	ORDER NO.	TERMINAL PITCH	TERMINAL WIDTH	TERMINAL LENGTH	TERMINAL SPACING	TERMINAL HEIGHT	TERMINAL DIAMETER	TERMINAL RADIUS	TERMINAL ANGLE
8.0	T.0	54722-0304	54722-0303	30	3.0	1.0	0.5	0.15	0.05	0.5
6.5	5.5	54722-0244	54722-0243	24	2.4	0.8	0.5	0.15	0.05	0.5
6.0	5.0	54722-0224	54722-0223	22	2.2	0.7	0.5	0.15	0.05	0.5
5.5	4.5	54722-0204	54722-0203	20	2.0	0.6	0.5	0.15	0.05	0.5
4.5	3.5	54722-0164	54722-0163	16	1.6	0.5	0.5	0.15	0.05	0.5

REVISED
 EC NO: J2010-1489
 DRWN: TOSHIMA
 CHKD: SMARUYAMA
 APPR: MSASAO

DESCRIPTION	DATE
10 UNDER	2010/02/01
10 OVER 30 UNDER	2010/02/02
30 OVER	2010/02/02

GENERAL TOLERANCES (UNLESS SPECIFIED)	ANGLE	PLATING
±0.2	±3°	±0.3
±0.25		
±0.3		

DATE	SCALE	DESIGN UNITS	MODEL NO.	THIRD ANGLE PROJECTION
03/08/20	1:1	MM ONLY	05 B-TO-B CONN REC ASSY	
03/08/20			[N BARRIER] (HGT=15)	
03/08/20			LEAD FREE	

Fig. Drawing A3 L.M.E.S
 Rev. D 2009/04/02

Calibration Mode (ACDL/MCDL)

ACDL function(Automatic Calibration Function in Dimming light with period)

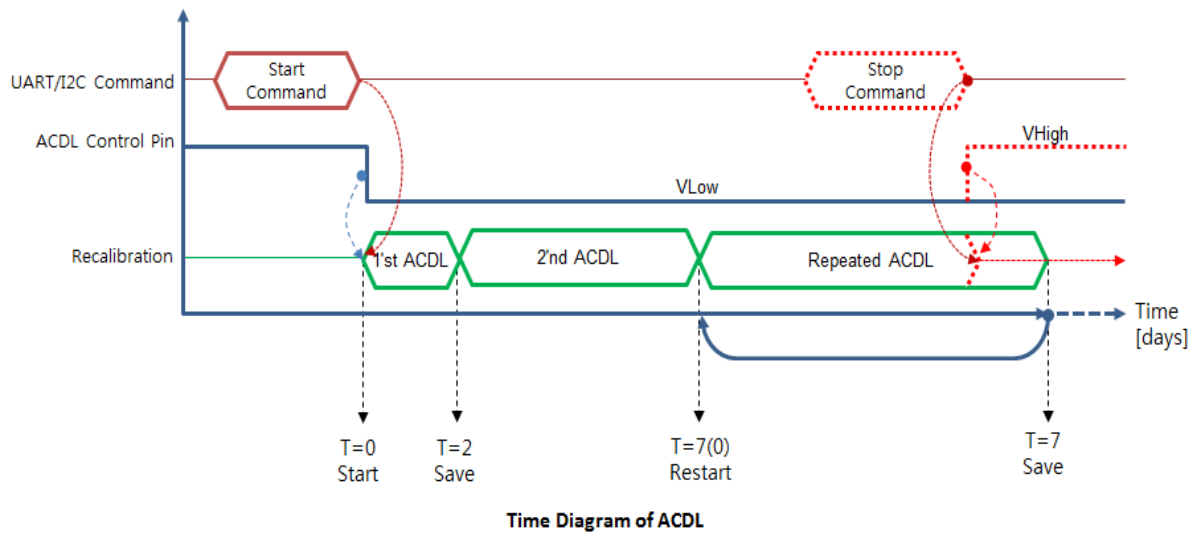

Method 1. UART Command Set; J1-3pin (UART-RX) and J1-5pin (UART-TX) to Main-Board.
(J2-13pin and J2-14pin are available for B to B connector User as well)

Method 2. I2C Command Set; J1-8pin (SCL) and J1-9pin (SDA) to Main-Board.

Method 3. Execute Hardware based ACDL.

- ※ 1. To activate ACDL function, the user's application must be designed to give Low-Active Signal to J1-6pin with High De-Active Signal to J1-10pin continuously.
(J2-6pin and J2-11pin are available for BtoB connector User as well)

- 2. T-200A has ACDL software in sensor, which make sensor always operate as ACDL unless MCDL is activated.

Method 4. Let Sensor install on Jig Board TRB-100ST (Test and Recalibration Board) with ambient air-flow condition and execute by moving jumper with Manual on the website.

Method 5. EK-100TL (Emulation kit, with Emulation program 'ELTWSO') is available, which display and save data on PC through USB connection.

10' MCDL function(10 minute Manual Calibration Function in Dimming light)

MCDL enable customer to calibrate as needed, MCDL keep at least 10 minute once it start and should be stopped before 18minute to avoid MCDL fetch repetition.

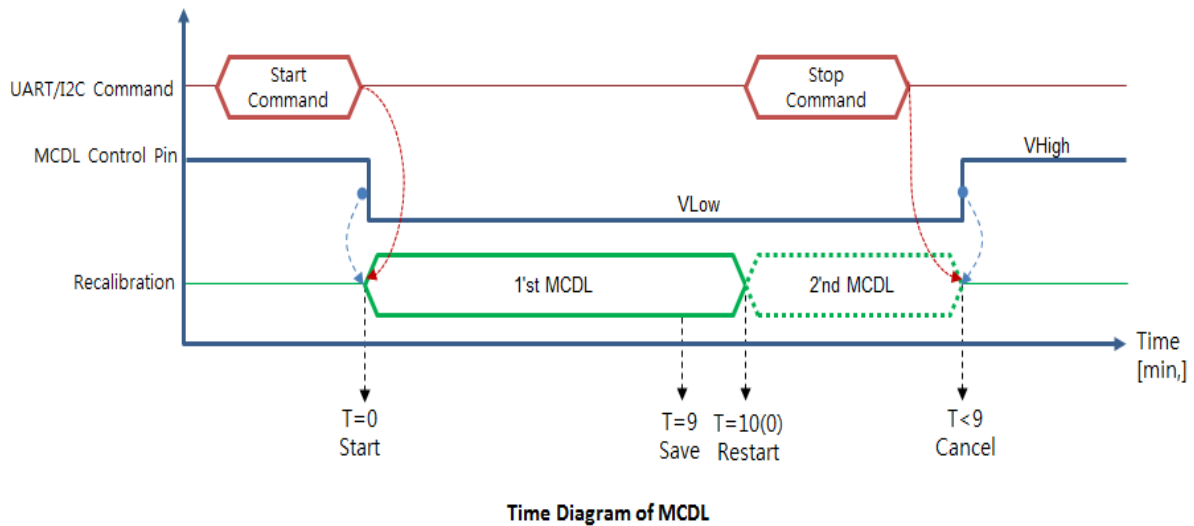

Method 1. UART Command Set; pin-3 (UART-RX) and pin-5 (UART-TX) to Main-Board.
(J2-13pin and J2-14pin are available for BtoB connector User as well)

Method 2. I2C Command Set; pin-8 (SCL) and pin-9 (SDA) to Main-Board.

Method 3. Execute Hardware based MCDL.

1. To activate ACDL function, the user's application must be designed to give Low-Active Signal to pin-10 with High De-Active Signal to pin-6 for 10 minutes. Be careful to make it sure to quit MCDL fetch loop before 18minute.
(J2-6pin and J2-11pin are available for BtoB connector User as well)
2. T-200A has ACDL software in sensor, which make sensor always operate as ACDL unless MCDL is activated.
3. Be careful to make it sure to quit MCDL fetch loop before 18minute.

Method 4. Let Sensor install on Jig Board TRB-100ST (Test and Recalibration Board) with ambient air-flow condition and execute by moving jumper with Manual on the website.

Method 5. EK-100TL (Emulation kit, with Emulation program 'ELTWSD') is available, which display and save data on PC through USB connection.

Set present CO2 value with Target PPM function

1. Deviated CO2 sensors can be adjusted with target PPM function via I2C or UART interface.
(Refer to 'I2C Programming guide' or 'UART Command guide')
2. EK-100SL (Evaluation kit, with Emulation program 'ELTWSL') is available for Target PPM function.
(Refer to 'EK-100TL manual')

Output Descriptions

UART Descriptions

Data Format

D6	D5	D4	D3	D2	D1	SP	'p'	'p'	'm'	CR	LF
----	----	----	----	----	----	----	-----	-----	-----	----	----

D6 ~ D1	6 byte CO2 density string
SP	Space: 0x20
'ppm'	'ppm' string
CR	Carriage return : 0x0D
LF	Line feed : 0x0A

Above 12byte consist by 6 byte hexadecimal digits, <SP>, 0x70 0x70 0x6D, <CR> <LF> , where decimal '0' (corresponds to hexadecimal digit '0x30') is replaced by space (corresponds to hexadecimal digit '0x20'),

EX) 1,255 ppm, results '0x20 0x20 0x31 0x32 0x35 0x35 0x20 0x70 0x70 0x6D 0x0D 0x0A', which displays '_1255_ppm<CR><LF>' on screen.

In need of detail command set, 'U-ART String Command Guide ' could be provided by contacting Sales Rep.

I2C Communication (Only Slave Mode Operation)

Internal pull up resistor

Slave Address: 0x31, Slave Address Byte: Slave Address(0x31) 7 Bit + R/W 1 Bit

Bit7	Bit6	Bit5	Bit4	Bit3	Bit2	Bit1	Bit0
0	1	1	0	0	0	1	R/W Bit

R/W Bit : Read = 1/Write = 0

When reading the data, Slave Address Byte is 0x63, When writing the data, Slave Address Byte is 0x62.

Block Diagram

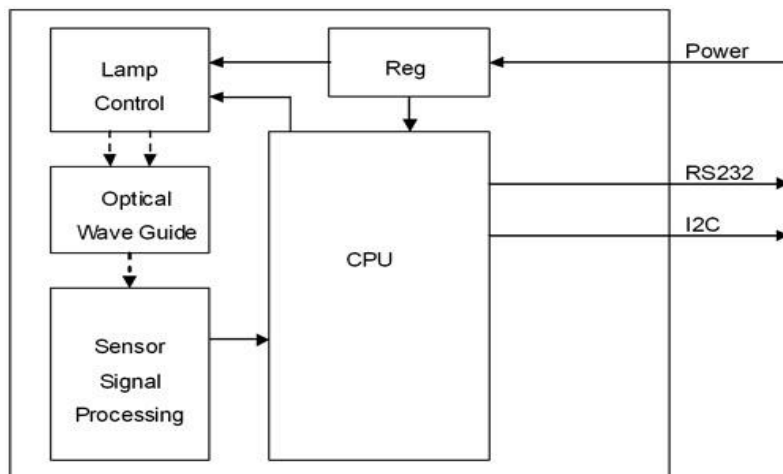

Transmission Sequence in Master

- 1) I2C Start Condition
- 2) Write Command(Slave Address + R/W Bit(0) = 0x62) Transmission and Check Acknowledge
- 3) Write Command(ASCII 'R' : 0x52) Transmission and Check Acknowledge
- 4) I2C Stop Command
- 5) I2C Start Command
- 6) Read Command(Slave Address + R/W Bit(1) = 0x63) Transmission and Check Acknowledge
- 7) Read 7 Byte Receiving Data from Module and Send Acknowledge
(Delay at least 1ms for reading each byte)

Configuration	CO ₂	reserved	reserved	reserved	reserved
1 Byte	2 Byte	0x00	0x00	0x00	0x00

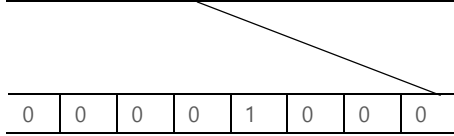

In need of detail protocol specification and time sequence, 'I2C programming guide' could be provided by contacting Sales Rep.

Analog Voltage Output Descriptions (Option)

Measured Voltage 0.5V~4.5V match proportionally to 0~ 2,000 each for 2,000 ppm scale sensor and any of 0~3,000 or 5,000 or 10,000 ppm scale sensor could be set by designating on sale. There-fore 3.0V will match 2,000 or 3,000 or 4,000 or 10,000 ppm or 2% or 3% or 5% or 10% each.

* CO₂ Measurement_(ppm) = ((Output Voltage - 0.5) / (4.5 - 0.5)Voltage) x F.S. ppm ,
 cf.F.S. (ppm) : 2,000/3,000/5,000/10,000 ppm (20,000/30,000/50,000/100,000 is optional.)

EX) if the Output Voltage is 2.5V in 2,000 ppm (F.S. of Reading range)

$$\begin{aligned} \text{CO}_2 \text{ Measurement}_{\text{ppm}} &= (2.5 - 0.5) \text{ V} \div (4.5 - 0.5) \text{ V} \times 2,000. \text{ ppm} \\ &= 2 \div 4 \times 2,000 \text{ ppm} = 1,000 \text{ ppm} \end{aligned}$$

PWM Descriptions (Option)

* $Measurement_{(ppm)} = (t_H - 2msec) / 1000msec \times Range_{(ppm)}$ (t_H : High Pulse Width)

* $Range_{(ppm)}$: 2,000/3,000/5,000/10,000 ppm (20,000/30,000/50,000/100,000 is optional.)

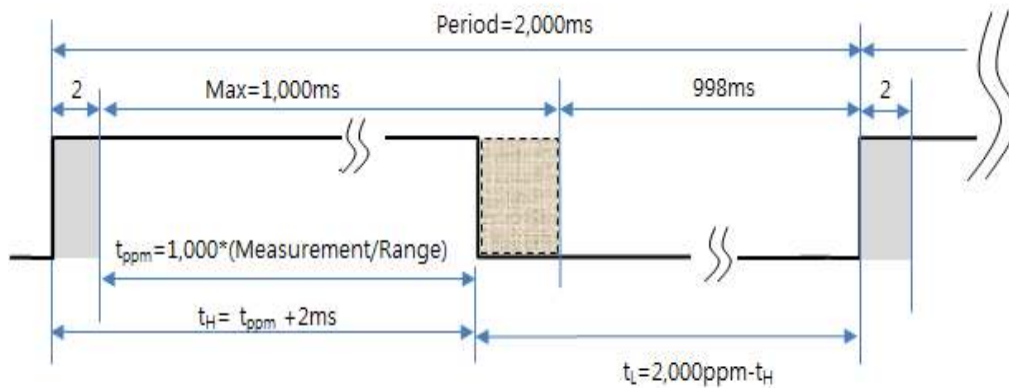

EX) t_H (High Pulse Width) calculation for 400ppm in 2,000 ppm Range.

* $Measurement_{(ppm)} = 400 \text{ ppm} = (t_H - 2ms) / 2,000msec \times Range_{(ppm)}$,

* $t_H = 1,000 \text{ msec} * (400 \text{ ppm} / 2,000ppm) + 2msec = 202msec$

(cf: $T_L = \text{Period} - t_H = 2,000ppm - 202 \text{ msec} = 1,798 \text{ msec.}$)

※ Caution

1. Please hold only 'PCB' of sensor without holding Cavity directly to avoid the physical shock on sensor. Rough handling or Transportation could result in inaccurate reading.
2. Proper ESD protection during handling is important to avoid electrostatic defect occurrence.
The storage of sensor should be insulated as well



ChunuiTechnopark 101-909)36,
Bucheon-ro 198beon-gil, 2015
Wonmi-gu, Bucheon-si, Gyeonggi-do, 420-857, Korea
Phone. +82-32-719-8055, <http://www.eltensor.co.kr>

Subject to change without notice. Printed in KOREA
ELT Sensor All rights reserved.
2017. Feb