

7361Z0001SxxLF

Lead Free Version (Optional)
Customer Specificity

GENERAL

This Smart Card Reader uses a sliding contact technology. It has been designed for easy mounting on metal panel.

ELECTRICAL PROPERTIES

Insulation resistance : 5000 M
Dielectric withstanding : 750 VAC
Current carrying capacity : 10 μ A min. 1A max.
Contact resistance : 100 m
Card sensor type : Blade switch normally closed

MECHANICAL PROPERTIES

EMV compatible and according to ISO 7816-2
Contact normal force : between 0.2 N to 0.6 N per contact
Insertion force : 10 N max.
Withdrawal force : 1 N min.
Max. number of mating operations : 10000 card insertions.

CAPACITOR :

100nF, chip size 0805 in (2012 mm), Y5V, 25V or 50V

READER MATERIAL

Housing : Thermoplastique, 30% GF, Colour black, Rated UL94V0
Contacts and switch : Phosphor bronze
Plating : precoat Nickel 2.5 μ m min. all over
Gold 0.2 μ m min. on contacts areas
SnPB 3 μ m min. on termination contacts for Leaded version
Matte Sn 3 μ on termination end for Leadfree version

ENVIRONMENT

Operating temperature : -20 °C / +70 °C
Storage temperature : -40 °C / +85 °C
Panel thickness : 0.8+-0.1 mm

PACKAGING

Trays
Packaging specification : VGN11646

LEAD FREE VERSION:

"This product meets European Union Directives and other country regulations as described in GS-22-008"

The housing will withstand exposure to 260°C peak temperature for 10seconds in a wave solder application with a 1.6mm minimum thick circuit board. Use protective adhesive tape (Kapton or Teflon) or protective metallic devices on the areas which are directly exposed to wave soldering as it is used in classical leaded wave soldering

B : TERMINAL PITCH

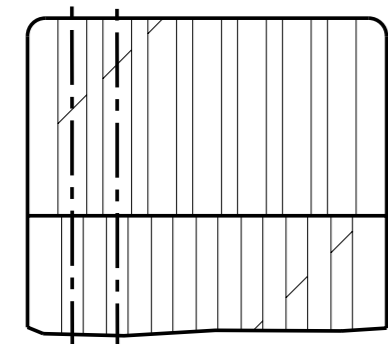

DETAIL A
SCALE 5/1

A : FLEX LENGTH

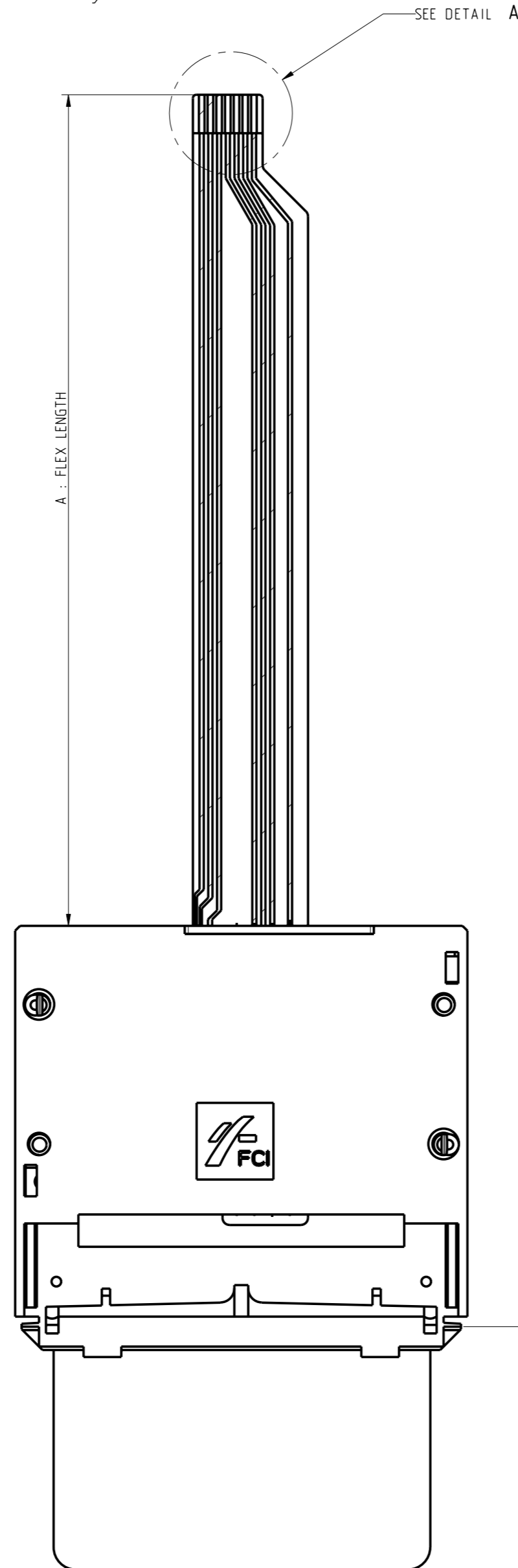

C : DISTANCE PANEL/CARD

SCALE 19/15

SCALE 3/2

www.fciconnect.com				surface	tolerance std	projection	MM	
				✓	Lin ± 0.1 Ang $\pm 0.5^\circ$		← →	
				TOLERANCES UNLESS OTHERWISE SPECIFIED				
rev	ecn no	dr	date	Dr	DILIPTHOMAS	2006/08/20	ANGULAR	LINEAR
B	105-0158	DTK	2005/09/11	Eng	DILIPTHOMAS	2005/08/20	0.x	±
C	106-0084	SSC	2006/06/21	Chr	DILIPTHOMAS	2006/06/21	0.xx	±
-	-	-	-	Appr	K.V.SIVADAS	2006/06/21	0.xxx	±
				Product family		size		Scale
						A2		1/1
						ECN		106-0084
						Spec ref		
						TITLE		Rev.
				READER PANEL MOUNT		VJW55019		C
				SMARTCARD		catalog no		SEE TABLE
						sheet 1 of 3		

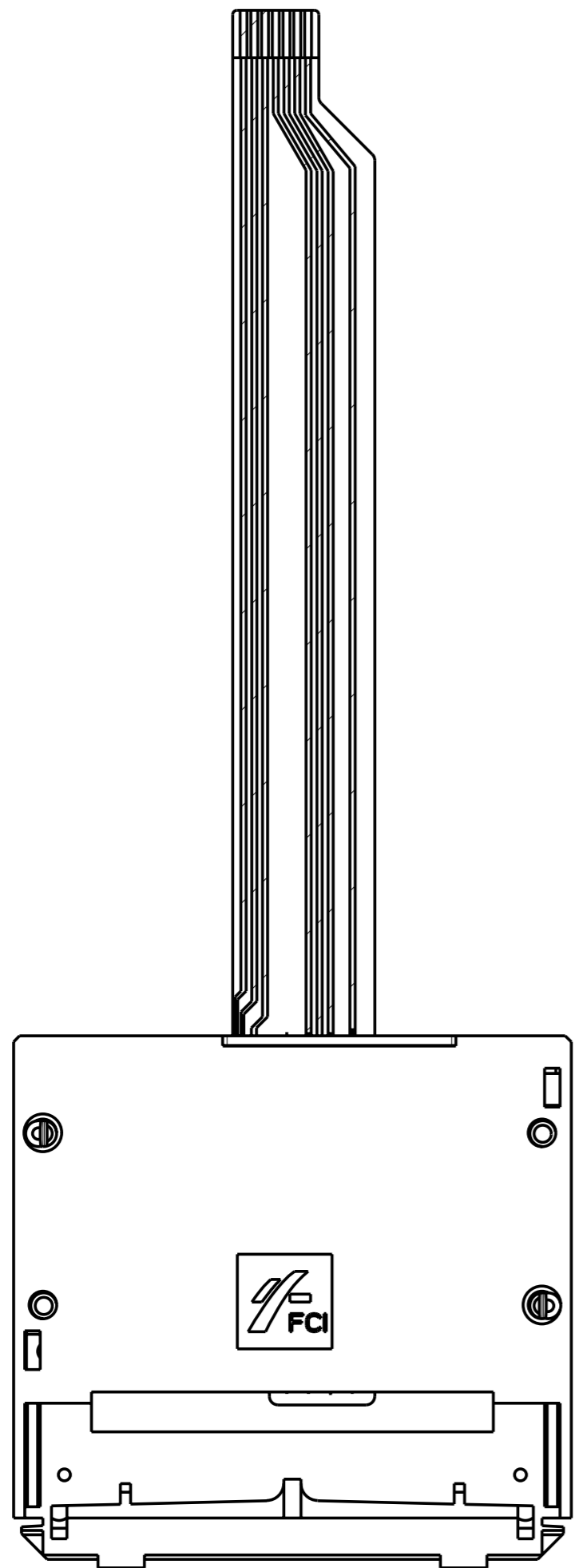
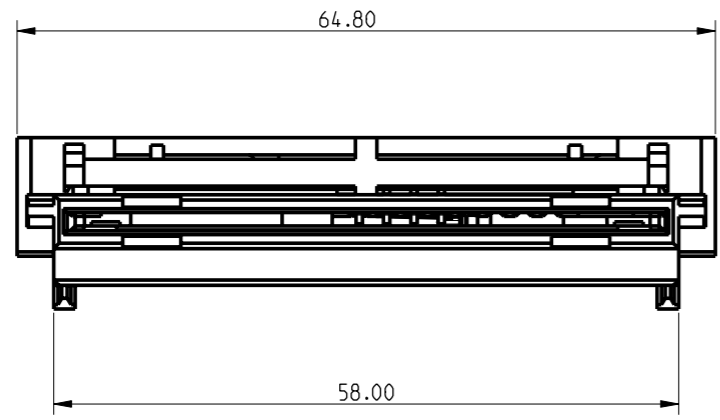

SCALE 3/2

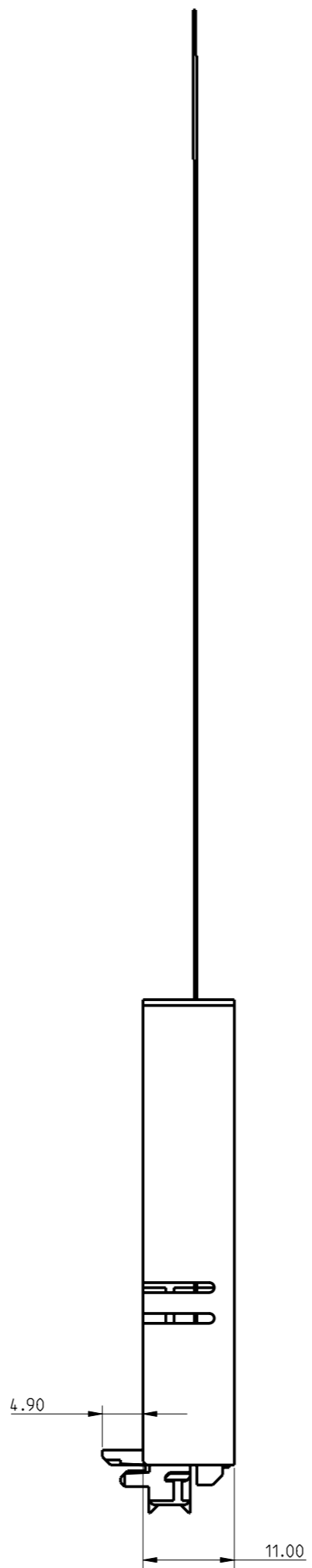

RECOMMENDED FRONT PANEL CUT-OUT

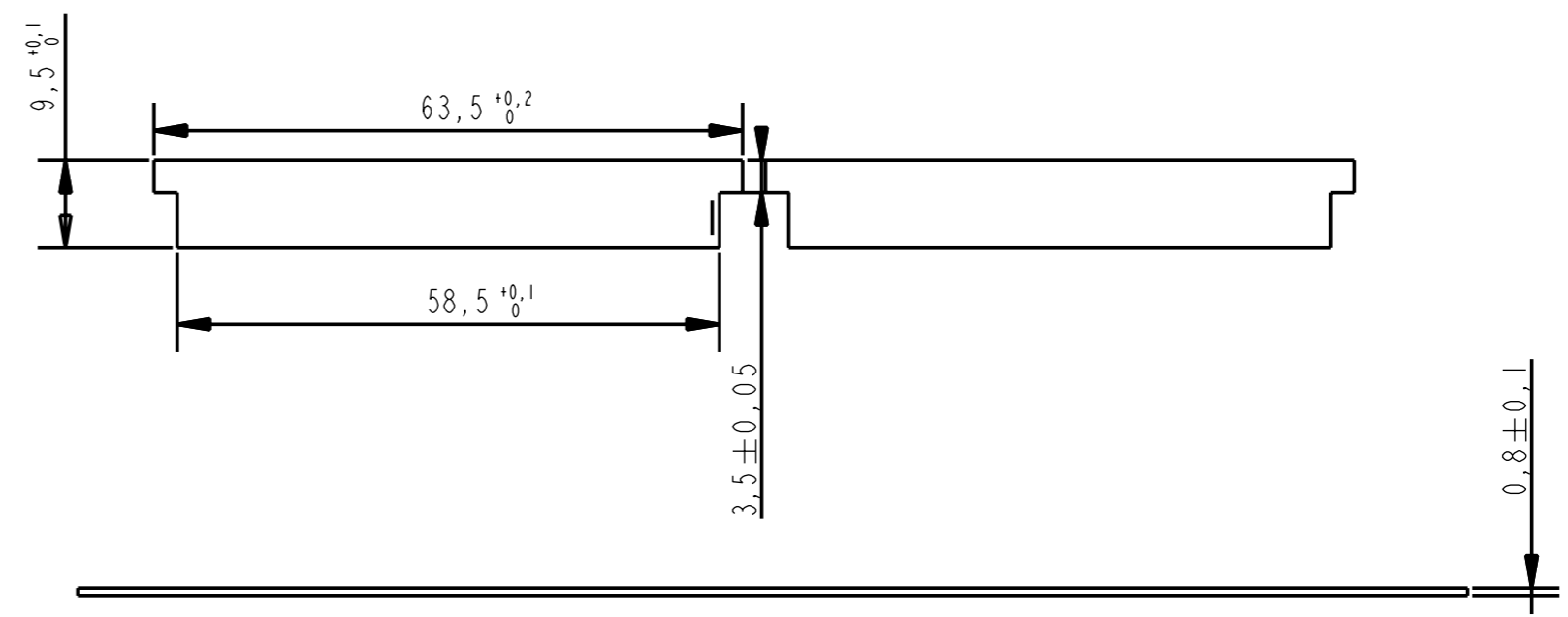

VERTICAL STACKING

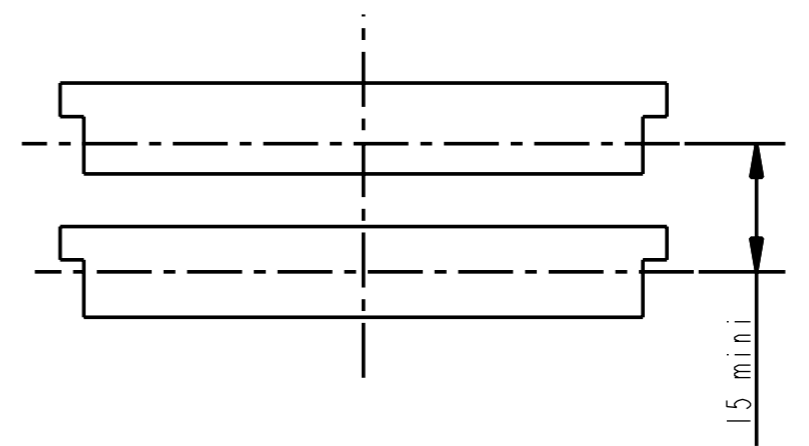

HORIZONTAL STACKING

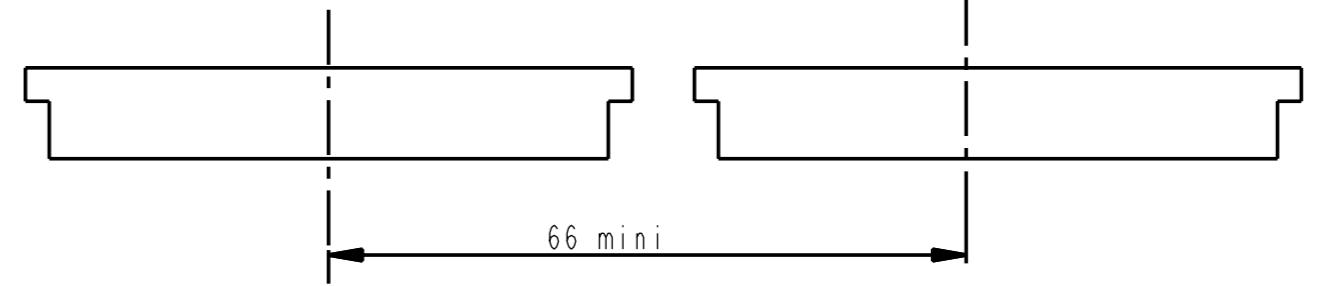

Copyright FCI. FCI

www.fciconnect.com		surface	tolerance std	projection	MM
		✓	Lin ±0.1 Ang ±0.5°	⊕	←→
		TOLERANCES UNLESS OTHERWISE SPECIFIED			Scale 1/1
Dr	DILIPTHOMAS	2006/08/20	ANGULAR	size	A2
Eng	DILIPTHOMAS	2005/08/20	LINEAR	ECN	106-0084
Chr	DILIPTHOMAS	2006/06/21	0° ±°	Spec ref	
Appr	K.V.SIVADAS	2006/06/21	Product family		
FCI		READER PANEL MOUNT		dwg no	VJW55019
SMARTCARD		SEE TABLE		Rev.	C
catalog no		SEE TABLE		sheet 2 of 3	

LIST OF PART NUMBERS

7x61Z0001SxxLF

X=3, STANDARD TRAY
X=5, ANTISTATIC TRAY

Lead Free Version (Optional)
Customer Specificity

PRODUCT NUMBER	A: FLEX LENGTH (mm)	B: TERMINAL PITCH (mm)	NUMBER OF TRACKS	FLEX FORM	CAPACITOR NUMBER	CONTACT NUMBER	C: DISTANCE PANEL/CARD (mm)	PACKING TYPE
7361Z0001S13	96	1	10	STRAIGHT	2	8 : ISO	35	A
7361Z0001S14	101	1	10	STRAIGHT	2	16 ISO+AFNOR	35	A
7361Z0001S15	96	1	10	STRAIGHT	2	8 : ISO	25	A
7361Z0001S22	156	1.25	10	STRAIGHT	1	16 ISO+AFNOR	35	A
7361Z0001S29	58	1.25	10	STRAIGHT	NONE	8 : ISO	35	A
7561Z0001S29	58	1.25	10	STRAIGHT	NONE	8 : ISO	35	A
7361Z0001S31	58	1.25	10	STRAIGHT	NONE	8 : ISO	25	A
7361Z0001S33	58	1.25	10	STRAIGHT	1	8 : ISO	35	A
7361Z0001S35	120	1.25	10	STRAIGHT	1	8 : ISO	35	A
7361Z0001S36	120	1.25	10	STRAIGHT	1	8 : ISO	15	B
7361Z0001S37	58	1.25	10	STRAIGHT	NONE	8 : ISO	15	B
7361Z0001S38	85	1.25	10	STRAIGHT	1	16 ISO+AFNOR	35	A
7361Z0001S39	58	1.25	10	STRAIGHT	NONE	8 : ISO	35	A
7361Z0001S40	118	1.25	7	STRAIGHT	1	8 : ISO	35	C
7361Z0001S41	118	1.25	7	STRAIGHT	1	8 : ISO	15	B
7361Z0001S42	60	1.25	7	STRAIGHT	NONE	8 : ISO	25	A
7361Z0001S43	58	1.25	10	STRAIGHT	1	8 : ISO	25	A

PACKING TYPE:
 A : 28 CONNECTORS / TRAY
 420 CONNECTORS / SHIPPING BOX
 B : 25 CONNECTORS / BLOCK
 500 CONNECTORS / SHIPPING BOX
 C : 12 CONNECTORS / TRAY
 120 CONNECTORS / SHIPPING BOX



Copyright FCI.

www.fciconnect.com		surface <input checked="" type="checkbox"/>	tolerance std Lin ±0.1 Ang ±0.5°	projection ⊕	MM
		TOLERANCES UNLESS OTHERWISE SPECIFIED		size A2	Scale 1/1
Dr	DILIPTHOMAS	2006/08/20	ANGULAR	0.x ±	
Eng	DILIPTHOMAS	2005/08/20	LINEAR	0.xx ±	
Chr	DILIPTHOMAS	2006/06/21	0° ±°	0.xxx ±	ECN 106-0084
Appr	K.V.SIVADAS	2006/06/21	Product family	Spec ref	
FCI		READER PANEL MOUNT		dwg no	VJW55019
		SMARTCARD		Rev.	C
		catalog no		SEE TABLE	
				sheet 3 of 3	