

Wireless Charging Coil Assembly

AWCCA-50N50



RoHS / RoHS II Compliant



50 x 50mm

Moisture Sensitivity Level (MSL) – MSL = 1

FEATURES:

- Wireless Charging Coil for Transmitter or Receiver applications, (6.3μH & 24μH options)
- Outline Dimensions: 50mm x 50mm, height options 3.5mm, 4.0mm or 5.0mm.
- For Tx or Rx Applications.
- High permeability shielding to protect sensitive electronics
- Durable construction
- RoHS / RoHS II Compliant & Pb free.

APPLICATIONS:

- Automotive Industry (in car charging)
- Batteries and Battery Chargers
- Consumer Electronics
- Smart Watches
- Digital Cameras and Camcorders
- Wireless Charging Stations
- Mobile Phones & Charging Accessories
- Power Supplies
- Power Tool Manufacturers

STANDARD SPECIFICATIONS

Maximum Ratings

Item	Value
Operating Temperature Range	-25°C to +85°C RH ≤ 90%.
Storage Temperature Range	-25°C to +85°C, 70% RH (Max.)

Electrical Characteristics

Part Number	Inductance	Q-Factor	Current Rating (rms)	Saturated Current (rms)	DC Resistance	SRF
AWCCA-50N50H35-C01-B	24μH ±10%	160±30%	5.4A Tpy.	21A	72m Ω±20%	3.0MHz
AWCCA-50N50H35-C02-B	6.3μH ±10%	72±30%	10.6A Tpy.	36A	19m Ω±20%	6.4MHz
AWCCA-50N50H40-C01-B	24μH ±10%	165±30%	5.7A Tpy.	27A	72m Ω±20%	2.9MHz
AWCCA-50N50H40-C02-B	6.3μH ±10%	72±30%	11.1A Tpy.	40A	19m Ω±20%	5.7MHz
AWCCA-50N50H50-C01-B	24μH ±10%	163±30%	5.7A Tpy.	30A	72m Ω±20%	2.8MHz
AWCCA-50N50H50-C02-B	6.3μH ±10%	75±30%	10.6A Tpy.	40A	19m Ω±20%	5.7MHz
Test Condition	100KHz / 1V	100KHz/1V	ΔT = 40 K	100KHz/1V	20±15°C	
Test Environment	Ambient Temperature: 20±15°C, RH: 65%±20%.					

Test Conditions

A) - Ambient Temperature: 20±15°C, RH: 65% ±20%.

If any doubt on the results, measurements/tests should be made within the following limits: Ambient Temperature: 20±2°C, RH: 65%±5%

B) - Isat: DC current at which the inductance drops approximate 5% from its value without current.

PART IDENTIFICATION:

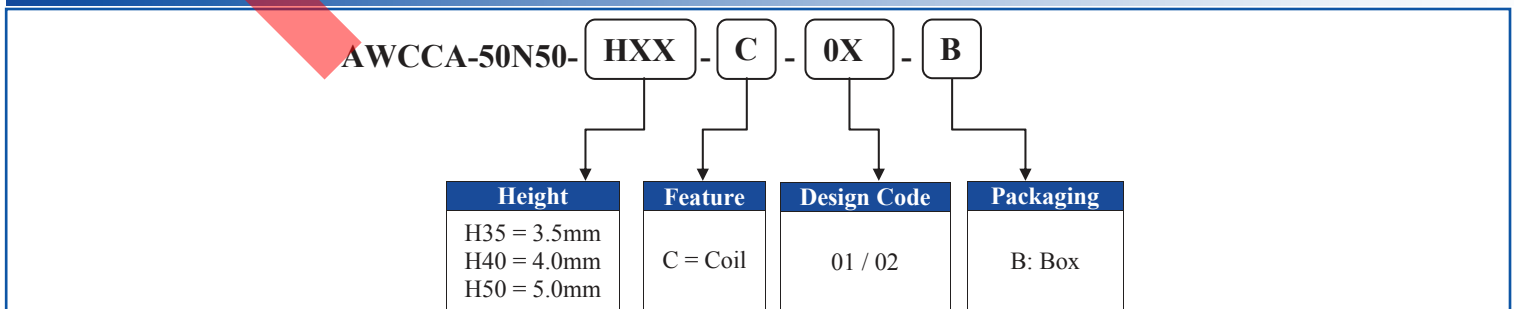

Wireless Charging Coil Assembly

AWCCA-50N50

 RoHS / RoHS II Compliant



50 x 50mm

OUTLINE DIMENSIONS:

Out Line Dimensions (unit mm)

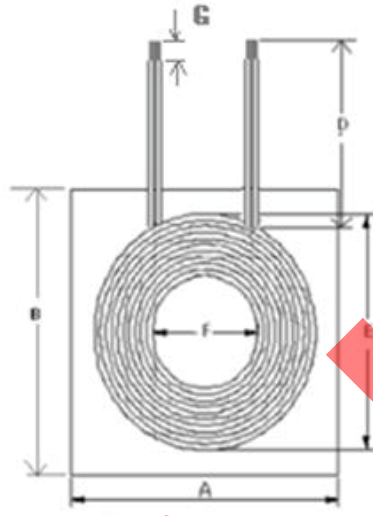

Part Number	A	B	C	D	E	F	G
AWCCA-50N50H35-C0X-B	50±1	50±1	3.5±0.5	50±3	44±1.5	20.5±0.5	5.0±2.0
AWCCA-50N50H40-C0X-B	50±1	50±1	4.0±0.5	50±3	44±1.5	20.5±0.5	5.0±2.0
AWCCA-50N50H50-C0X-B	50±1	50±1	5.0±0.5	50±3	44±1.5	20.5±0.5	5.0±2.0

Winding Specifications

Nominal Code	Number of Coils	Wire	Number of Turns	Inductance
C01	1	0.08×105	20	24μH ±10%
C02	1	0.08×105X2P	10	6.3μH ±10%

Product Customization

Products can be customized according to the Wireless Charging Coil Standards or to customer requirements. Please refer to the following table for the feature ranges, and contact ABRACON or authorized distributor / agent for further details.

Inductance Range [μH]	DC Resistance Range [mΩ]	Dimension Range [mm]	Thickness range [mm]
1 ~ 100	10 ~ 1000	10 ~ 200	0.4 ~ 10

Manual Soldering: 350°C Max, 3secs

Storage condition

- Recommended storage conditions: -25°C~85°C, 70%RH (Max.)
- Service life: Within the limits of six month from being produced.
- The appearance and solder ability should be check, if product is not in expiry date.

Operation Conditions

- Use condition limit: T=-25°C ~ 85°C, RH≤ 90%.

ATTENTION: Abracon LLC's products are COTS – Commercial-Off-The-Shelf products; suitable for Commercial, Industrial and, where designated, Automotive Applications. Abracon's products are not specifically designed for Military, Aviation, Aerospace, Life-dependent Medical applications or any application requiring high reliability where component failure could result in loss of life and/or property. For applications requiring high reliability and/or presenting an extreme operating environment, written consent and authorization from Abracon LLC is required. Please contact Abracon LLC for more information.