



STEVAl-CCH002V2

HDMI and video switches demonstration board

Data brief

Features

- 16-character x 2-line alphanumeric backlit LCD
- VGA input and output connectors
- S-video input and output connectors
- Y Pb Pr input and output connector sets
- CVBS input and output connectors
- DVI-I input connector
- Analog and digital switch selection jumper sets
- Power supply section
- Reset switch
- RoHS compliant

Description

The STEVAL-CCH002V2 demonstrates the functions and performance of STMicroelectronics' STHDMI002A, STDVE103A, STDVE001A, STMAV340, and STHDMI002A digital switches/equalizers, and STMAV335 and STMAV340 analog switches.

The purpose of the board is to demonstrate the capabilities of ST's video switches and buffers (while providing an example of the appropriate use of signal line protection devices in all I/O lines) for both standard analog or high-speed TMDS (transition minimized differential signaling) digital signals.

The board consists of several input/output connectors and supports VGA (RGB), Y Pb Pr (component video), DVI-I analog, CVBS (composite video) and S-video analog formats, as well as HDMI and DVI-I digital formats.

Demonstration of the various devices is achieved by setting the appropriate jumpers on the demonstration board.

Also included is a 2-line backlit LCD with 16 characters-per-line, which displays the selection status as well as the control signals sensed by the preprogrammed microcontroller.

May 2010

Doc ID 17472 Rev 1

1/9

For further information contact your local STMicroelectronics sales office.

www.st.com

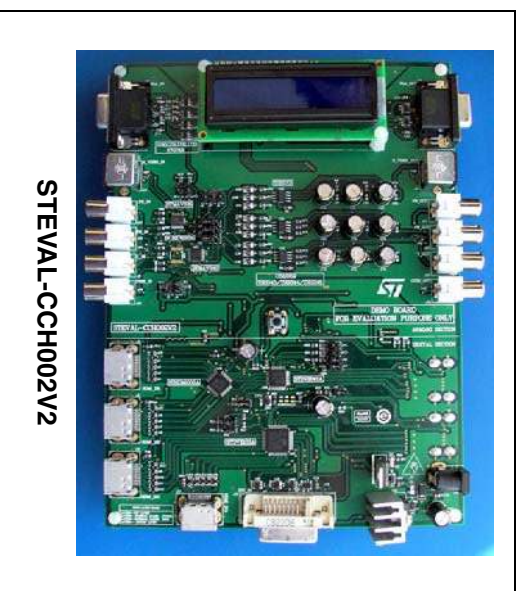

1 Schematic diagrams

Figure 1. STEVAL-CH002V2 circuit schematics (1 of 6)

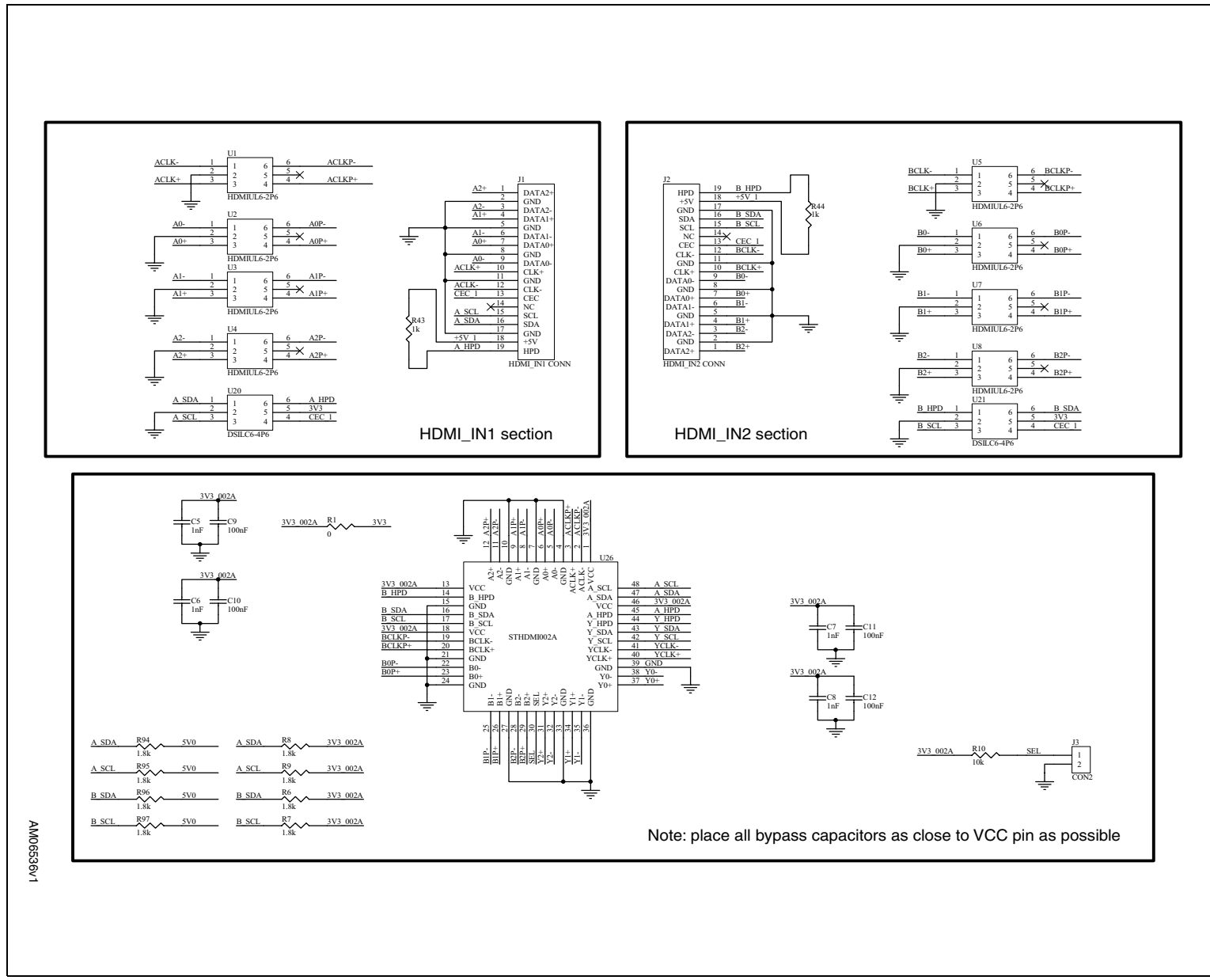

AM06536v1



Figure 3. STEVAL-CCH002V2 circuit schematics (3 of 6)

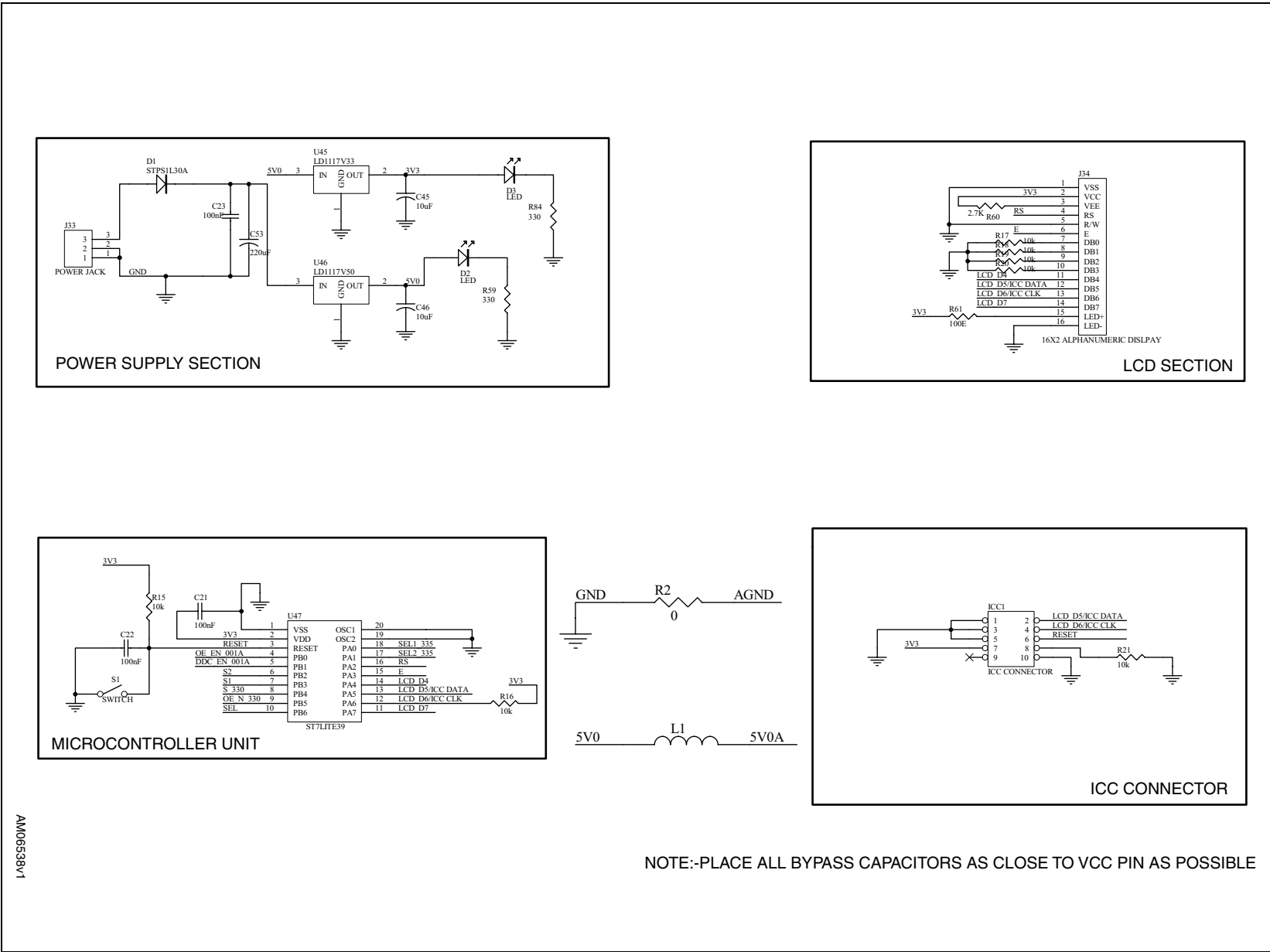

NOTE:-PLACE ALL BYPASS CAPACITORS AS CLOSE TO VCC PIN AS POSSIBLE



Figure 5. STEVAL-CCH002V2 circuit schematics (5 of 6)

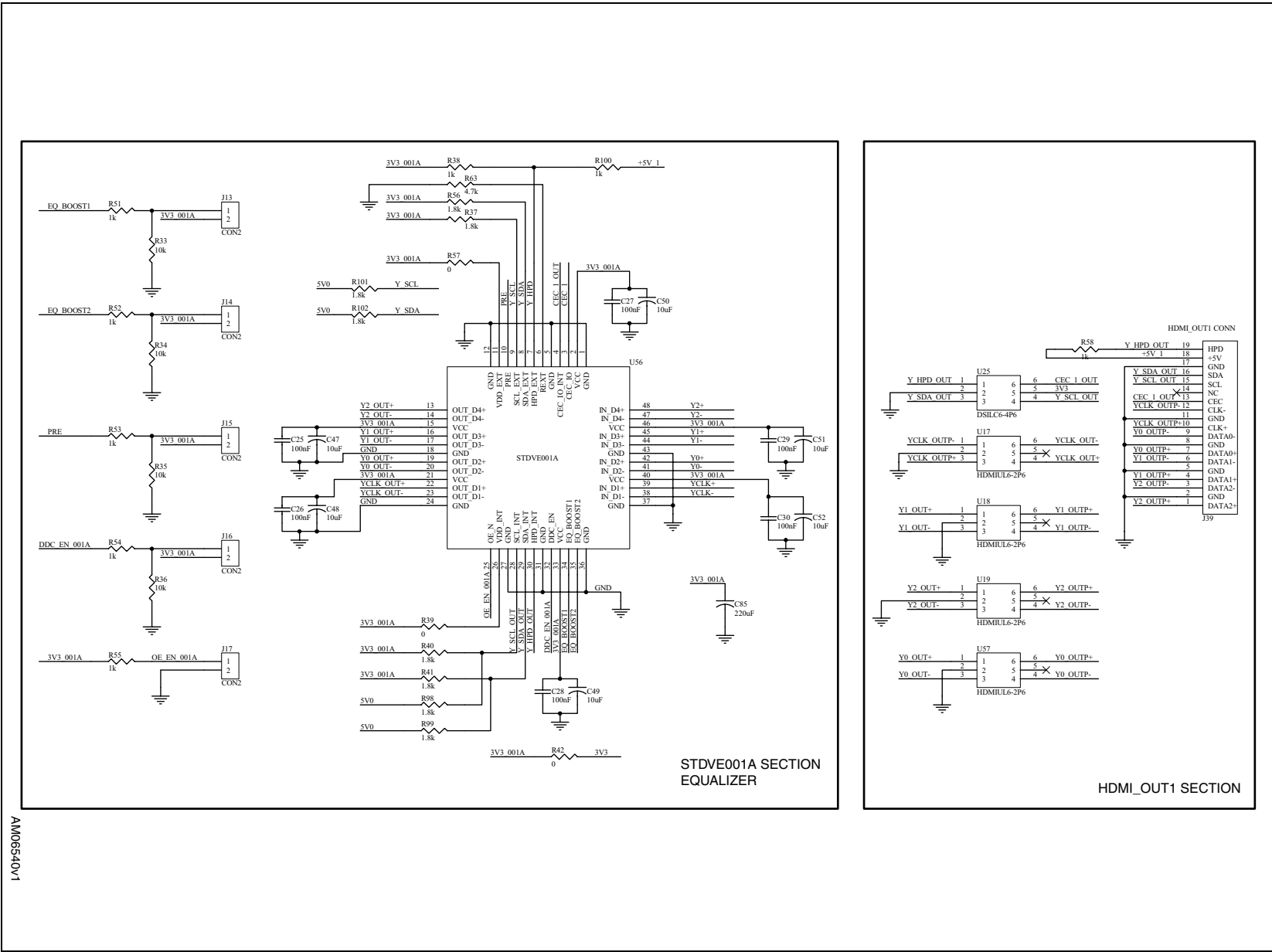
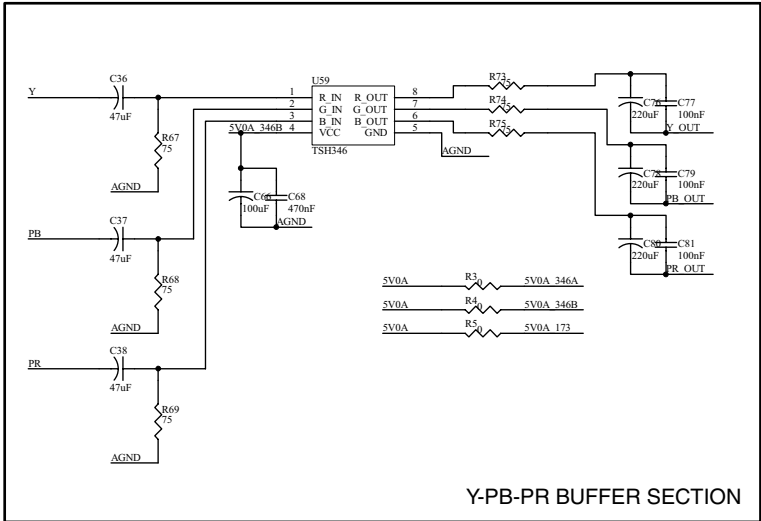
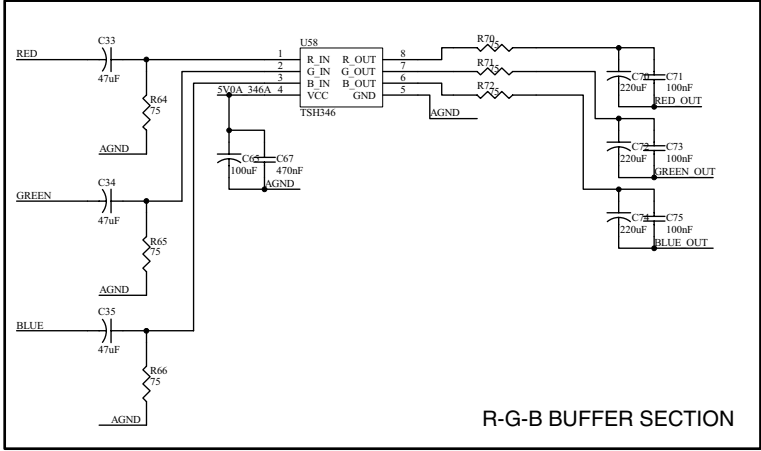
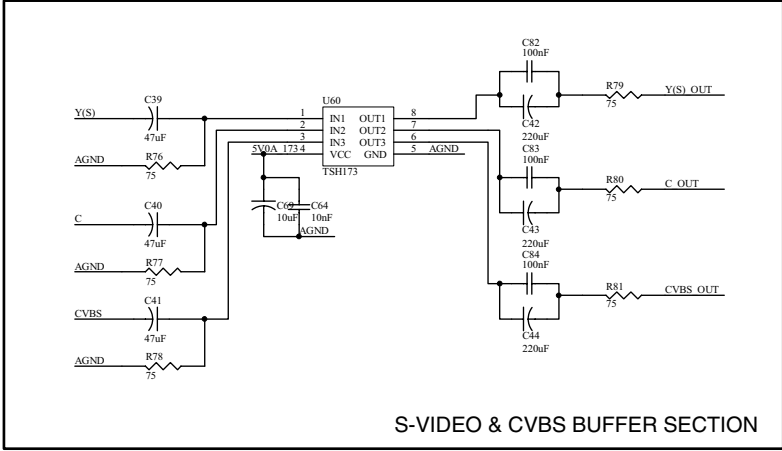

Figure 6. STEVAL-CCH002V2 circuit schematics (6 of 6)



2 Revision history

Table 1. Document revision history

Date	Revision	Changes
04-May-2010	1	Initial release.

Please Read Carefully:

Information in this document is provided solely in connection with ST products. STMicroelectronics NV and its subsidiaries ("ST") reserve the right to make changes, corrections, modifications or improvements, to this document, and the products and services described herein at any time, without notice.

All ST products are sold pursuant to ST's terms and conditions of sale.

Purchasers are solely responsible for the choice, selection and use of the ST products and services described herein, and ST assumes no liability whatsoever relating to the choice, selection or use of the ST products and services described herein.

No license, express or implied, by estoppel or otherwise, to any intellectual property rights is granted under this document. If any part of this document refers to any third party products or services it shall not be deemed a license grant by ST for the use of such third party products or services, or any intellectual property contained therein or considered as a warranty covering the use in any manner whatsoever of such third party products or services or any intellectual property contained therein.

UNLESS OTHERWISE SET FORTH IN ST'S TERMS AND CONDITIONS OF SALE ST DISCLAIMS ANY EXPRESS OR IMPLIED WARRANTY WITH RESPECT TO THE USE AND/OR SALE OF ST PRODUCTS INCLUDING WITHOUT LIMITATION IMPLIED WARRANTIES OF MERCHANTABILITY, FITNESS FOR A PARTICULAR PURPOSE (AND THEIR EQUIVALENTS UNDER THE LAWS OF ANY JURISDICTION), OR INFRINGEMENT OF ANY PATENT, COPYRIGHT OR OTHER INTELLECTUAL PROPERTY RIGHT.

UNLESS EXPRESSLY APPROVED IN WRITING BY AN AUTHORIZED ST REPRESENTATIVE, ST PRODUCTS ARE NOT RECOMMENDED, AUTHORIZED OR WARRANTED FOR USE IN MILITARY, AIR CRAFT, SPACE, LIFE SAVING, OR LIFE SUSTAINING APPLICATIONS, NOR IN PRODUCTS OR SYSTEMS WHERE FAILURE OR MALFUNCTION MAY RESULT IN PERSONAL INJURY, DEATH, OR SEVERE PROPERTY OR ENVIRONMENTAL DAMAGE. ST PRODUCTS WHICH ARE NOT SPECIFIED AS "AUTOMOTIVE GRADE" MAY ONLY BE USED IN AUTOMOTIVE APPLICATIONS AT USER'S OWN RISK.

Resale of ST products with provisions different from the statements and/or technical features set forth in this document shall immediately void any warranty granted by ST for the ST product or service described herein and shall not create or extend in any manner whatsoever, any liability of ST.

ST and the ST logo are trademarks or registered trademarks of ST in various countries.

Information in this document supersedes and replaces all information previously supplied.

The ST logo is a registered trademark of STMicroelectronics. All other names are the property of their respective owners.

© 2010 STMicroelectronics - All rights reserved

STMicroelectronics group of companies

Australia - Belgium - Brazil - Canada - China - Czech Republic - Finland - France - Germany - Hong Kong - India - Israel - Italy - Japan - Malaysia - Malta - Morocco - Philippines - Singapore - Spain - Sweden - Switzerland - United Kingdom - United States of America

www.st.com

