



ANATECH ELECTRONICS INC
RF & Microwave Filters & Products

4350 MHz High Pass Filter

Part Number: AE4350H9919



Electrical Specifications

Cutoff Frequency: 4350 MHz
Passband(PB): 4350-5050 MHz Min.
Insertion Loss in PB : 1.37 dB Max.
VSWR: 1.5:1 Max.
Rejection: ≥65dB @ 2800 MHz
Impedance: 50 Ohms
Power Handling: 1 Watt

Mechanical

Connector Type: SMT
Dimensions: 25.4 X 9.65 x 9.65 mm.

Environmental

Operating Temperature: -55°C to +85°C
Storage Temperature: -60°C to +90°C
Shock: 10 G. 11ms
Vibration: 10 G. 5 to 200Hz
Relative Humidity : 95 %

Outline Drawing:

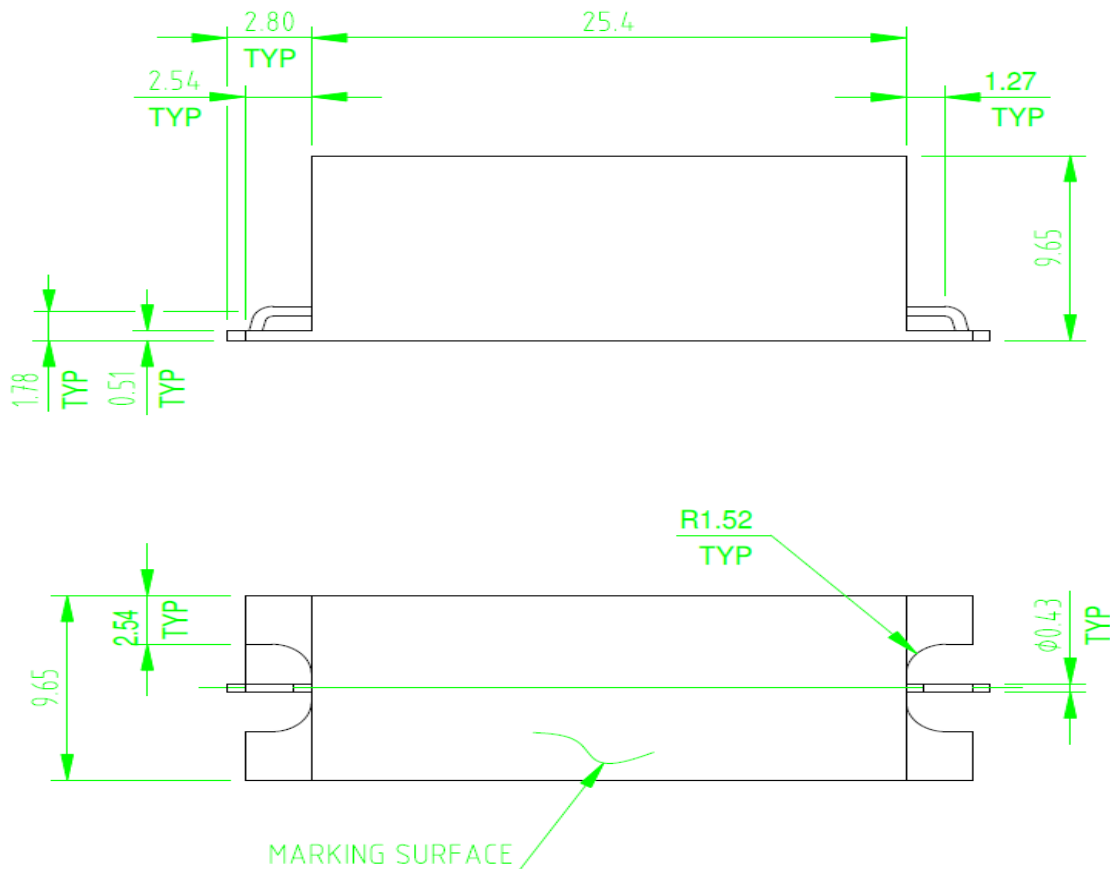

Tolerance: +/-0.01 inches [+/- 0.3mm]

Angles: +/- 1 Deg.

*Tolerance as shown unless otherwise specified in the datasheet electrical specification tables above.

*When max dimensions are called out the above tolerances do not apply as long as it is under the max call out.

70 Outwater Lane Phone: (973) 772-4242
Garfield, NJ 07026 Fax : (973) 321-3941

Email: sales@anatechelectronics.com
Web: www.anatechelectronics.com



Simulation Plot:

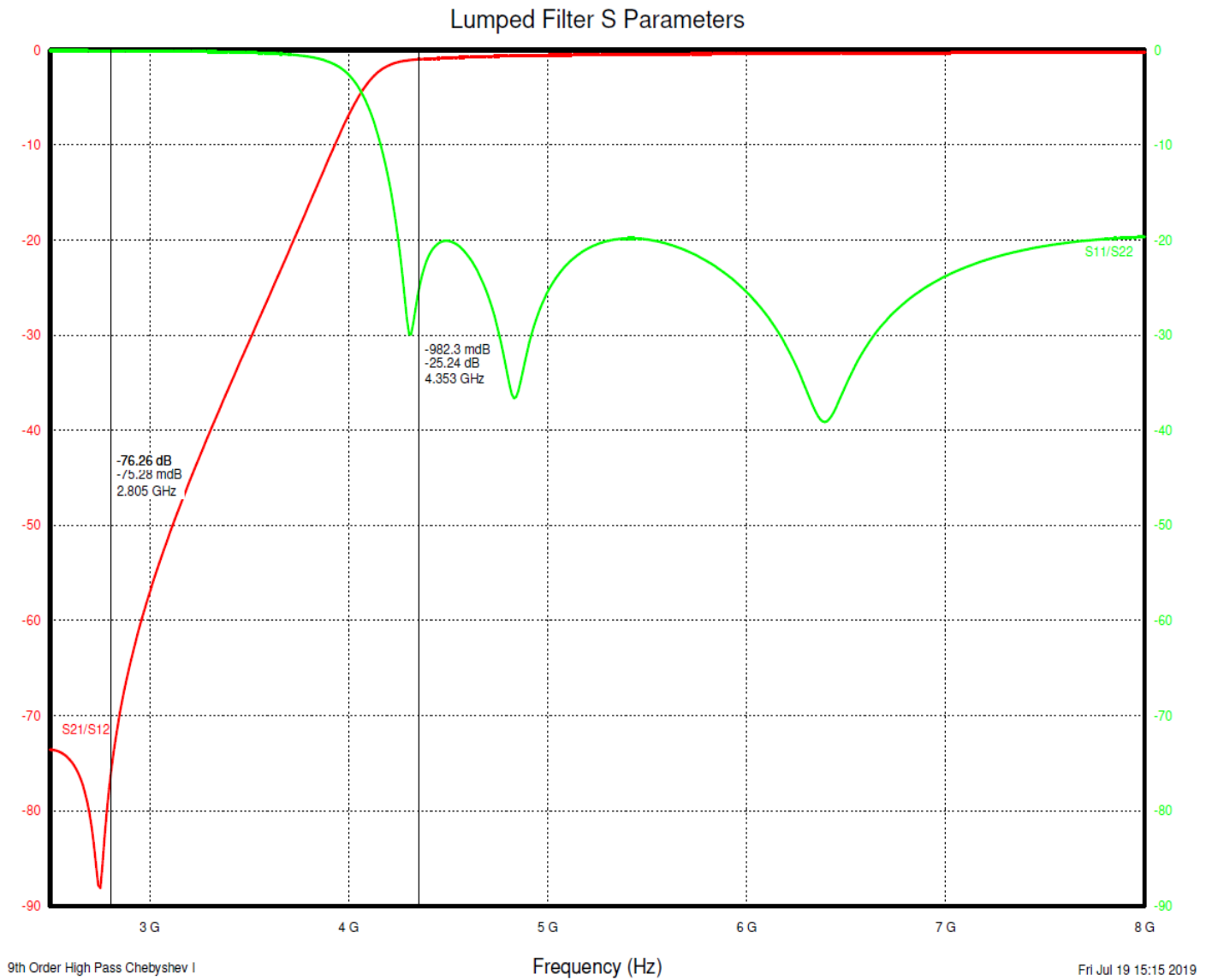

Note: This is a simulation Plot. Actual response plot might differ once product is manufactured.