

# HiPerFAST™ IGBT Lightspeed™ Series

**IXGA 7N60C  
IXGP 7N60C**

$V_{CES} = 600 \text{ V}$   
 $I_{C25} = 14 \text{ A}$   
 $V_{CE(sat)} = 2.7 \text{ V}$   
 $t_{fi} = 45 \text{ ns}$

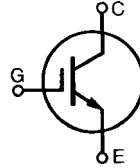

| Symbol  | Test Conditions   | Maximum Ratings                  |                                      |
|---|---|----------------------------------|--------------------------------------|
| $V_{CES}$   | $T_J = 25^\circ\text{C to } 150^\circ\text{C}$  | 600                              | V                                    |
| $V_{CGR}$   | $T_J = 25^\circ\text{C to } 150^\circ\text{C}; R_{GE} = 1 \text{ M}\Omega$  | 600                              | V                                    |
| $V_{GES}$   | Continuous  | $\pm 20$                         | V                                    |
| $V_{GEM}$   | Transient   | $\pm 30$                         | V                                    |
| $I_{C25}$   | $T_C = 25^\circ\text{C}$  | 14                               | A                                    |
| $I_{C90}$   | $T_C = 90^\circ\text{C}$  | 7                                | A                                    |
| $I_{CM}$  | $T_C = 25^\circ\text{C}, 1 \text{ ms}$  | 30                               | A                                    |
| <b>SSOA<br/>(RBSOA)</b>   | $V_{GE} = 15 \text{ V}, T_{VJ} = 125^\circ\text{C}, R_G = 22 \Omega$<br>Clamped inductive load, $L = 300 \mu\text{H}$ | $I_{CM} = 14$<br>@ $0.8 V_{CES}$ | A                                    |
| $P_C$   | $T_C = 25^\circ\text{C}$  | 54                               | W                                    |
| $T_J$   |   | -55 ... +150                     | C                                    |
| $T_{JM}$  |   | 150                              | C                                    |
| $T_{stg}$   |   | -55 ... +150                     | C                                    |
| Maximum lead temperature for soldering<br>1.6 mm (0.062 in.) from case for 10 s |   | 300                              | C                                    |
| $M_d$   | Mounting torque, (TO-220)   | M3<br>M3.5                       | 0.45/4 Nm/lb.in.<br>0.55/5 Nm/lb.in. |
| <b>Weight</b>   | TO-220  |                                  | 4 g                                  |
|   | TO-263  |                                  | 2 g                                  |

**TO-220AB (IXGP)**

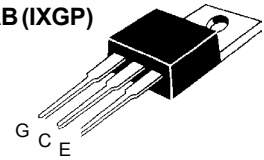

**TO-263 AA (IXGA)**

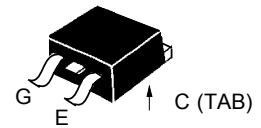

G = Gate, C = Collector,  
E = Emitter, TAB = Collector

### Features

- International standard packages JEDEC TO-263 surface mountable and JEDEC TO-220 AB
- High frequency IGBT
- High current handling capability
- HiPerFAST™ HDMOS™ process
- MOS Gate turn-on - drive simplicity

### Applications

- Uninterruptible power supplies (UPS)
- Switched-mode and resonant-mode power supplies
- AC motor speed control
- DC servo and robot drives
- DC choppers

### Advantages

- High power density
- Suitable for surface mounting
- Very low switching losses for high frequency applications

| Symbol        | Test Conditions  | Characteristic Values<br>( $T_J = 25^\circ\text{C}$ , unless otherwise specified) |      |                      |
|---------------|--|---|------|----------------------|
|               |  | min.  | typ. | max.                 |
| $BV_{CES}$    | $I_C = 250 \mu\text{A}, V_{GE} = 0 \text{ V}$          | 600   |      | V                    |
| $V_{GE(th)}$  | $I_C = 250 \mu\text{A}, V_{CE} = V_{GE}$               | 2.5   |      | 5.5 V                |
| $I_{CES}$     | $V_{CE} = 0.8 \cdot V_{CES}$<br>$V_{GE} = 0 \text{ V}$ | $T_J = 25^\circ\text{C}$  |      | 100 $\mu\text{A}$    |
|               |  | $T_J = 125^\circ\text{C}$   |      | 500 $\mu\text{A}$    |
| $I_{GES}$     | $V_{CE} = 0 \text{ V}, V_{GE} = \pm 20 \text{ V}$      |   |      | $\pm 100 \text{ nA}$ |
| $V_{CE(sat)}$ | $I_C = I_{C90}, V_{GE} = 15 \text{ V}$                 | 2.0   | 2.7  | V                    |

| Symbol       | Test Conditions  | Characteristic Values<br>( $T_J = 25^\circ\text{C}$ , unless otherwise specified) |      |         |
|--------------|--|---|------|---------|
|              |  | min.  | typ. | max.    |
| $g_{fs}$     | $I_C = I_{C90}, V_{CE} = 10\text{ V}$ ,<br>Pulse test, $t \leq 300 \mu\text{s}$ , duty cycle $\leq 2\%$  | 3   | 7    | S       |
| $C_{ies}$    | $V_{CE} = 25\text{ V}, V_{GE} = 0\text{ V}, f = 1\text{ MHz}$  |   | 500  | pF      |
| $C_{oes}$    |  |   | 50   | pF      |
| $C_{res}$    |  |   | 17   | pF      |
| $Q_g$        | $I_C = I_{C90}, V_{GE} = 15\text{ V}, V_{CE} = 0.5 V_{CES}$  |   | 25   | nC      |
| $Q_{ge}$     |  |   | 5    | nC      |
| $Q_{gc}$     |  |   | 10   | nC      |
| $t_{d(on)}$  | <b>Inductive load, <math>T_J = 25^\circ\text{C}</math></b><br>$I_C = I_{C90}, V_{GE} = 15\text{ V}, L = 300 \mu\text{H}$ ,<br>$V_{CE} = 0.8 V_{CES}, R_G = R_{off} = 22 \Omega$<br>Remarks: Switching times may increase for $V_{CE}(\text{Clamp}) > 0.8 \cdot V_{CES}$ ,<br>higher $T_J$ or increased $R_G$ |   | 9    | ns      |
| $t_{ri}$     |  |   | 10   | ns      |
| $E_{on}$     |  |   | 0.07 | mJ      |
| $t_{d(off)}$ |  |   | 65   | 130 ns  |
| $t_{fi}$     |  |   | 45   | 110 ns  |
| $E_{off}$    |  |   | 0.12 | 0.25 mJ |
| $t_{d(on)}$  | <b>Inductive load, <math>T_J = 125^\circ\text{C}</math></b><br>$I_C = I_{C90}, V_{GE} = 15\text{ V}, L = 300 \mu\text{H}$<br>$V_{CE} = 0.8 V_{CES}, R_G = R_{off} = 22 \Omega$<br>Remarks: Switching times may increase for $V_{CE}(\text{Clamp}) > 0.8 \cdot V_{CES}$ ,<br>higher $T_J$ or increased $R_G$  |   | 10   | ns      |
| $t_{ri}$     |  |   | 15   | ns      |
| $E_{on}$     |  |   | 0.07 | mJ      |
| $t_{d(off)}$ |  |   | 120  | ns      |
| $t_{fi}$     |  |   | 85   | ns      |
| $E_{off}$    |  |   | 0.22 | mJ      |
| $R_{thJC}$   |  |   |      | 2.3 K/W |
| $R_{thCK}$   | (TO-220)   |   | 0.25 | K/W     |

### TO-220 AB Outline

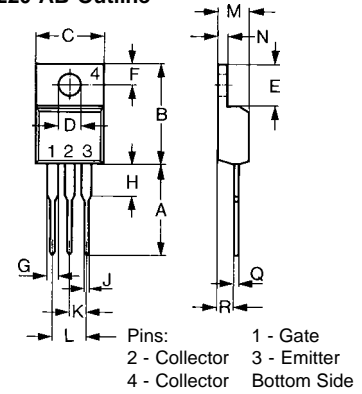

| Dim. | Millimeter |       | Inches |       |
|------|------------|-------|--------|-------|
|      | Min.       | Max.  | Min.   | Max.  |
| A    | 12.70      | 13.97 | 0.500  | 0.550 |
| B    | 14.73      | 16.00 | 0.580  | 0.630 |
| C    | 9.91       | 10.66 | 0.390  | 0.420 |
| D    | 3.54       | 4.08  | 0.139  | 0.161 |
| E    | 5.85       | 6.85  | 0.230  | 0.270 |
| F    | 2.54       | 3.18  | 0.100  | 0.125 |
| G    | 1.15       | 1.65  | 0.045  | 0.065 |
| H    | 2.79       | 5.84  | 0.110  | 0.230 |
| J    | 0.64       | 1.01  | 0.025  | 0.040 |
| K    | 2.54       | BSC   | 0.100  | BSC   |
| M    | 4.32       | 4.82  | 0.170  | 0.190 |
| N    | 1.14       | 1.39  | 0.045  | 0.055 |
| Q    | 0.35       | 0.56  | 0.014  | 0.022 |
| R    | 2.29       | 2.79  | 0.090  | 0.110 |

### TO-263 AA Outline

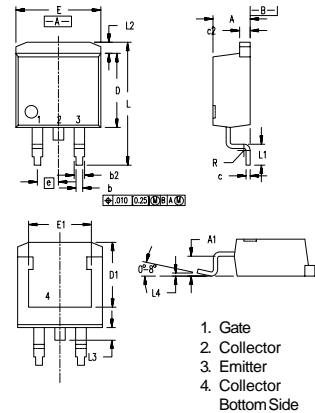

| Dim. | Millimeter |       | Inches |      |
|------|------------|-------|--------|------|
|      | Min.       | Max.  | Min.   | Max. |
| A    | 4.06       | 4.83  | .160   | .190 |
| A1   | 2.03       | 2.79  | .080   | .110 |
| b    | 0.51       | 0.99  | .020   | .039 |
| b2   | 1.14       | 1.40  | .045   | .055 |
| c    | 0.46       | 0.74  | .018   | .029 |
| c2   | 1.14       | 1.40  | .045   | .055 |
| D    | 8.64       | 9.65  | .340   | .380 |
| D1   | 7.11       | 8.13  | .280   | .320 |
| E    | 9.65       | 10.29 | .380   | .405 |
| E1   | 6.86       | 8.13  | .270   | .320 |
| e    | 2.54       | BSC   | .100   | BSC  |
| L    | 14.61      | 15.88 | .575   | .625 |
| L1   | 2.29       | 2.79  | .090   | .110 |
| L2   | 1.02       | 1.40  | .040   | .055 |
| L3   | 1.27       | 1.78  | .050   | .070 |
| L4   | 0          | 0.38  | 0      | .015 |
| R    | 0.46       | 0.74  | .018   | .029 |

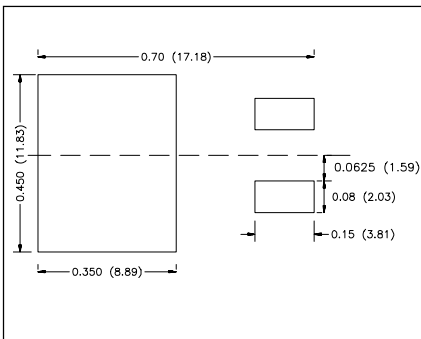

### Min. Recommended Footprint (Dimensions in inches and mm)

IXYS reserves the right to change limits, test conditions, and dimensions.