

JNW350R Power Modules; DC-DC Converters

36 – 75 Vdc Input; 28Vdc Output; 350W Output

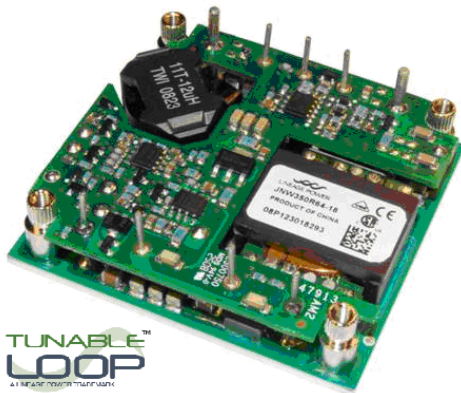

**TUNABLE
LOOP**
A1 REGULATOR TECHNOLOGY

RoHS Compliant

Applications

- RF Power Amplifier
- Wireless Networks
- Switching Networks

Options

- Auto-restart after either output OCP or OVP fault shutdown ("3" option code)
- Auto-restart only after output OCP fault shutdown ("4" option code)
- Shorter pins ("6" or "8" option code)
- Unthreaded heatsink holes (-18 option code)
- Tunable Loop™ for transient response optimization (-T option code)

Features

- Compliant to RoHS EU Directive 2011/65/EU (Z versions)
- Compliant to RoHS EU Directive 2011/65/EU under exemption 7b (Lead solder exemption). Exemption 7b will expire after June 1, 2016 at which time this product will no longer be RoHS compliant (non-Z versions)
- Compliant to IPC-9592, Class I, Category 2
- High power density: 129 W/in³
- Industry standard half-brick pin-out
- Industry standard half-brick footprint
57.7mm x 60.7mm x 12.7mm
(2.27" x 2.39" x 0.5")
- 2:1 input voltage range
- Low output ripple and noise
- Constant switching frequency
- Single tightly regulated output
- No minimum load required
- Remote Sense
- Output voltage adjustment trim, 16.8V_{dc} to 32.0V_{dc}
- Accepts transient overloads without shutdown
- Latch after output OVP/OCP fault shutdown
- Over temperature protection, auto restart
- Wide operating case temperature range (-40°C to 100°C)
- CE mark meets 2006/95/EC directives§
- UL60950-1/CSA† C22.2 No. 60950-1-03 Certified (cCSAus) and VDE‡ 0805:2001-12 (EN60950-1) Licensed
- ISO** 9001 and ISO 14001 certified manufacturing facilities

Description

The JNW350R series of dc-dc converters are a new generation of isolated DC/DC power modules providing up to 350W output power in an industry standard half-brick size footprint, which makes it an ideal choice for high voltage and high power applications. Threaded-through holes are provided to allow easy mounting or addition of a heatsink for high-temperature applications. The output is fully isolated from the input, allowing versatile polarity configurations and grounding connections. This module contains an optional new feature, the Tunable Loop™, that allows the user to optimize the dynamic response of the converter to match the load with reduced amount of output capacitance, leading to savings on cost and PWB area.

JNW350R Power Modules; DC-DC Converters

36 – 75 Vdc Input; 28Vdc Output; 350W Output

Absolute Maximum Ratings

Stresses in excess of the absolute maximum ratings can cause permanent damage to the device. These are absolute stress ratings only, functional operation of the device is not implied at these or any other conditions in excess of those given in the operations sections of the data sheet. Exposure to absolute maximum ratings for extended periods can adversely affect the device reliability.

Parameter	Device	Symbol	Min	Max	Unit
Input Voltage					
Continuous	All	V_{IN}	-0.3	80	V_{dc}
Transient, operational (≤ 100 ms)	All	$V_{IN,trans}$	-0.3	100	V_{dc}
Operating Ambient Temperature					
Note: When the operating ambient temperature is within 55°C –85°C, the application of the module refers to the derating curves of Figures 21 and 22.	All	T_a	-40	85	°C
Operating Case Temperature (See Thermal Considerations section, Figure 20)	All	T_c	-40	100	°C
Storage Temperature	All	T_{stg}	-55	125	°C
I/O Isolation Voltage: Input to Case, Input to Output	All	—	—	1500	V_{dc}
Output to Case	All	—	—	500	V_{dc}

Electrical Specifications

Unless otherwise indicated, specifications apply over all operating input voltage, resistive load, and temperature conditions.

Parameter	Device	Symbol	Min	Typ	Max	Unit
Operating Input Voltage (see Figure 12 for $V_{IN,min}$ when using trim-up feature)	All	V_{IN}	36	48	75	V_{dc}
Maximum Input Current ($V_{IN}=36V$ to $75V$, $I_O=I_{O,max}$)	All	$I_{IN,max}$			12.5	A_{dc}
Inrush Transient	All	I^2t			2	A^2s
Input Reflected Ripple Current, peak-to-peak (5Hz to 20MHz, 12 μ H source impedance; $V_{IN}=0V$ to $75V$, $I_O=I_{O,max}$; see Figure 7)	All				20	mA_{p-p}
Input Ripple Rejection (120Hz)	All			50		dB

CAUTION: This power module is not internally fused. An input line fuse must always be used.

This power module can be used in a wide variety of applications, ranging from simple standalone operation to being an integrated part of complex power architecture. To preserve maximum flexibility, internal fusing is not included. Always use an input line fuse, to achieve maximum safety and system protection. The safety agencies require a time-delay or fast-acting fuse with a maximum rating of 20 A (see Safety Considerations section). Based on the information provided in this data sheet on inrush energy and maximum dc input current, the same type of fuse with a lower rating can be used. Refer to the fuse manufacturer's data sheet for further information.

JNW350R Power Modules; DC-DC Converters

36 – 75 Vdc Input; 28Vdc Output; 350W Output

Electrical Specifications (continued)

Parameter	Device	Symbol	Min	Typ	Max	Unit
Output Voltage Set-point ($V_{IN}=V_{IN,nom}$, $I_O=I_{O,max}$, $T_C=25^\circ\text{C}$)	All	$V_{O,set}$	27.5	28	28.5	V _{dc}
Output Voltage (Over all operating input voltage, resistive load, and temperature conditions until end of life)	All	V_O	27.15	—	28.85	V _{dc}
Output Regulation Line ($V_{IN}=V_{IN,min}$ to $V_{IN,max}$) Load ($I_O=I_{O,min}$ to $I_{O,max}$) Temperature ($T_C = -40^\circ\text{C}$ to $+100^\circ\text{C}$)	All All All		— — —	0.1 0.1 0.5	0.2 0.2 1.5	% $V_{O,set}$ % $V_{O,set}$ % $V_{O,set}$
Output Ripple and Noise on nominal output ($V_{IN}=V_{IN,nom}$ and $I_O=I_{O,min}$ to $I_{O,max}$) RMS (5Hz to 20MHz bandwidth) Peak-to-Peak (5Hz to 20MHz bandwidth) ¹	All All		— —	45 80	55 200	mV _{rms} mV _{pk-pk}
External Capacitance (ESR > 50 mΩ) ² Without the Tunable Loop™ (ESR _{MAX} = 80mΩ) ² With the Tunable Loop™ (ESR > 50 mΩ) ³	All, except - T -T -T	C_O C_O C_O	440 440 440		6500 470 8,000	μF μF μF
Output Current ¹	All	I_O	0		12.5	A _{dc}
Output Current Limit Inception	All	$I_{O,lim}$	13.1	—	17.5	A _{dc}
Output Short Circuit Current ($V_O \leq 0.25V_{dc}$)	All	$I_{O,sc}$			30	A _{rms}
Efficiency $V_{IN}=V_{IN,nom}$, $T_C=25^\circ\text{C}$, $I_O=I_{O,max}$, $V_O=V_{O,set}$	All	η	—	92	—	%
Switching Frequency		f_{sw}	—	300	—	kHz
Dynamic Load Response ($\Delta I_O/\Delta t=1A/10\mu\text{s}$; $V_{in}=V_{in,nom}$; $T_C=25^\circ\text{C}$; Tested with a 470 μF aluminum and a 10 μF ceramic capacitor across the load.) Load Change from $I_O=50\%$ to 75% of $I_{O,max}$: Peak Deviation Settling Time ($V_O < 10\%$ peak deviation) Load Change from $I_O=25\%$ to 50% of $I_{O,max}$: Peak Deviation Settling Time ($V_O < 10\%$ peak deviation)	All	V_{pk} t_s V_{pk} t_s	— — — —	2 1.5 2 1.5	— — — —	% $V_{O,set}$ ms % $V_{O,set}$ ms

1. When operating at output current between 0A_{dc} and 1A_{dc}, output ripple may exceed maximum pk-pk limits.

2. Use a minimum 2 × 220μF output capacitor. Recommended capacitor is Nichicon CD series, 220μF/35V. If the ambient temperature is less than 0°C, use 3x of the minimum C_O.

3. External capacitors may require using the new Tunable Loop™ feature to ensure that the module is stable as well as getting the best transient response. See the Tunable Loop™ section for details.

Isolation Specifications

Parameter	Symbol	Min	Typ	Max	Unit
Isolation Capacitance	C_{iso}	—	15	—	nF
Isolation Resistance	R_{iso}	10	—	—	MΩ

General Specifications

Parameter	Device	Symbol	Min	Typ	Max	Unit
Calculated Reliability based upon Telcordia SR-332 Issue 2: Method I Case 3 ($I_O=80\%I_{O,max}$, $T_A=40^\circ\text{C}$, airflow = 200 lfm, 90% confidence)	All	FIT		379		10 ⁹ /Hours
		MTBF		2,638,332		Hours
Weight	All		—	78	—	g
				2.8		oz.

JNW350R Power Modules; DC-DC Converters

36 – 75 Vdc Input; 28Vdc Output; 350W Output

Feature Specifications

Unless otherwise indicated, specifications apply over all operating input voltage, resistive load, and temperature conditions. See Feature Descriptions for additional information.

Parameter	Device	Symbol	Min	Typ	Max	Unit
Remote On/Off Signal Interface ($V_{IN}=V_{IN, min}$ to $V_{IN, max}$; open collector or equivalent, Signal referenced to V_{IN} -terminal) Negative Logic: device code suffix "1" Logic Low = module On, Logic High = module Off Positive Logic: No device code suffix required Logic Low = module Off, Logic High = module On Logic Low - Remote On/Off Current Logic Low - On/Off Voltage Logic High Voltage - (Typ = Open Collector) Logic High maximum allowable leakage current	All	$I_{on/off}$	—	—	1.0	mA
	All	$V_{on/off}$	0	—	1.2	V _{dc}
	All	$V_{on/off}$	—	—	5	V _{dc}
	All	$I_{on/off}$	—	—	50	μA
Turn-On Delay and Rise Times ($V_{in}=V_{in,nom}$, $I_o=I_o,max$, $T_c=25C$) Case 1: T_{delay} = Time until $V_o = 10\%$ of $V_{o,set}$ from application of V_{in} with Remote On/Off set to ON, Case 2: T_{delay} = Time until $V_o = 10\%$ of $V_{o,set}$ from application of Remote On/Off from Off to On with V_{in} already applied for at least one second. T_{rise} = time for V_o to rise from 10% of $V_{o,set}$ to 90% of $V_{o,set}$.	All	T_{delay}	—	85	—	ms
	All	T_{delay}	—	25	30	ms
	All	T_{rise}	—	25	—	ms
Output Voltage Overshoot ($I_o=80\%$ of I_o,max , $T_c=25C$)					3	% $V_{o,set}$
Output Voltage Adjustment (See Feature Descriptions): Output Voltage Remote-sense Range (only for No Trim or Trim down application) Output Voltage Set-point Adjustment Range (trim)	All	V_{sense}	—	—	2	% $V_{o,nom}$
	All	V_{trim}	16.8	—	32.0	V _{dc}
Output Over-voltage Protection	All	$V_{o,limit}$	34	—	38	V _{dc}
Over Temperature Protection (See Feature Descriptions)	All	T_{ref}	—	110	—	°C
Input Under Voltage Lockout Turn-on Threshold Turn-off Threshold Hysteresis	All	$V_{IN,UVLO}$		35	36	V _{dc}
	All		31	32		V _{dc}
	All			3		V _{dc}
Input Over voltage Lockout Turn-on Threshold Turn-off Threshold Hysteresis	All	$V_{IN,OVLO}$		79.5	81	V _{dc}
	All		81	83		V _{dc}
	All		---	3	---	V _{dc}

JNW350R Power Modules; DC-DC Converters

36 – 75 Vdc Input; 28Vdc Output; 350W Output

Characteristic Curves

The following figures provide typical characteristics for the JNW350R (28V, 12.5A) at 25°C. The figures are identical for either positive or negative Remote On/Off logic.

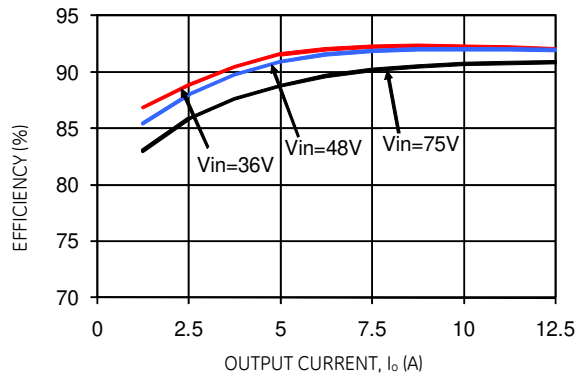

Figure 1. Converter Efficiency versus Output Current.

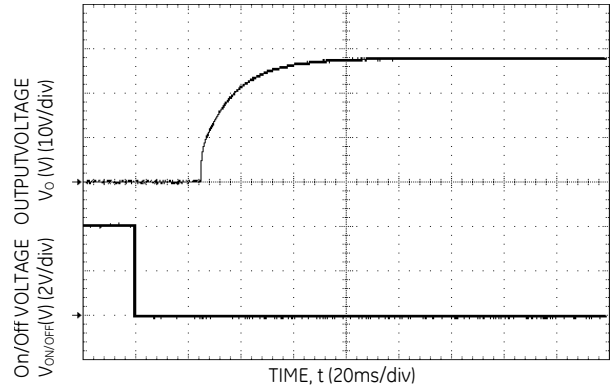

Figure 4. Typical Start-Up Using negative Remote On/Off; $C_{o,ext} = 470\mu F$.

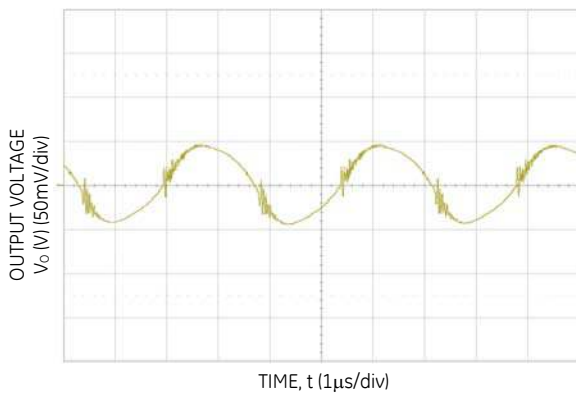

Figure 2. Typical Output Ripple and Noise at Room Temperature and 48Vin; $I_o = I_{o,max}$; $C_{o,ext} = 470\mu F$.

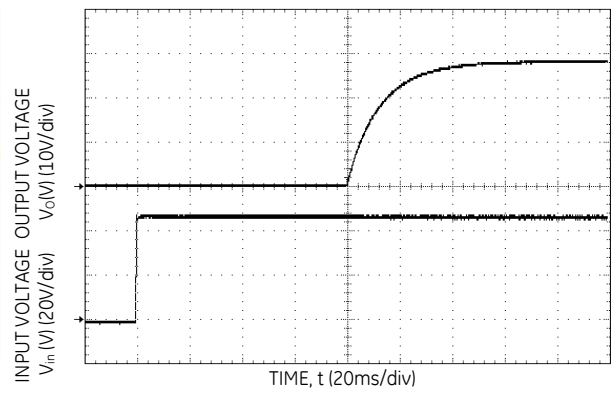

Figure 5. Typical Start-Up from V_{IN} , on/off enabled prior to V_{IN} step; $C_{o,ext} = 470\mu F$.

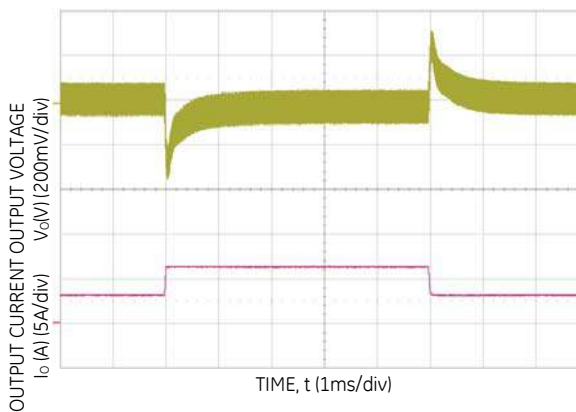

Figure 3. Standard JNW350R Transient Response to Dynamic Load Change from 25% to 50% to 25% of Full Load at Room Temperature and 48 Vdc Input; 0.1A/μS, $C_{o,ext} = 470\mu F$

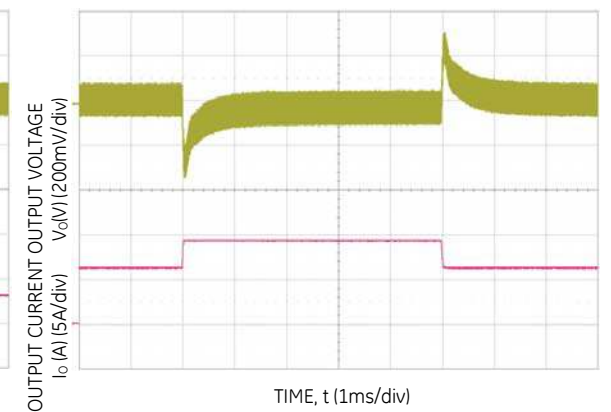
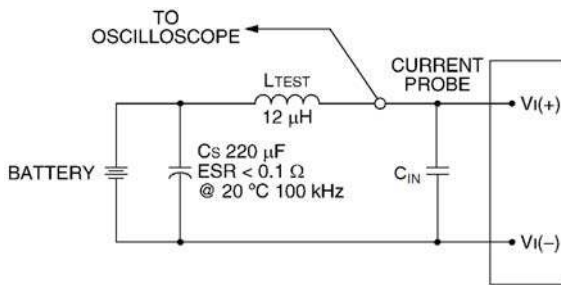

Figure 6. Standard JNW350R Transient Response to Dynamic Load Change from 50% to 75% to 50% of Full Load at Room Temperature and 48 Vdc Input; 0.1A/μS, $C_{o,ext} = 470\mu F$

JNW350R Power Modules; DC-DC Converters

36 – 75 Vdc Input; 28Vdc Output; 350W Output

Test Configurations



Note: Measure the input reflected-ripple current with a simulated source inductance (LTEST) of 12 μH. Capacitor CS offsets possible battery impedance. Measure the current, as shown above.

Figure 7. Input Reflected Ripple Current Test Setup.

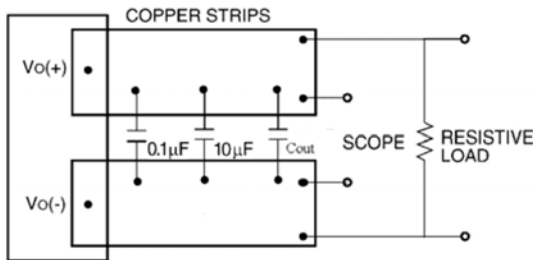

Note: Use a Cout (470 μF Low ESR aluminum or tantalum capacitor typical), a 0.1 μF ceramic capacitor and a 10 μF ceramic capacitor, and Scope measurement should be made using a BNC socket. Position the load between 51 mm and 76 mm (2 in. and 3 in.) from the module.

Figure 8. Output Ripple and Noise Test Setup.

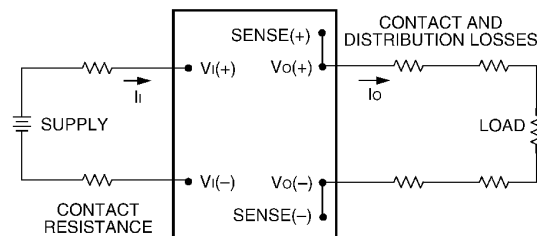

Note: All measurements are taken at the module terminals. When socketing, place Kelvin connections at module terminals to avoid measurement errors due to socket contact resistance.

$$\eta = \left(\frac{[V_{O(+)} - V_{O(-)}] I_{O}}{[V_{I(+)} - V_{I(-)}] I_{I}} \right) \times 100 \%$$

Figure 9. Output Voltage and Efficiency Test Setup.

Design Considerations

Input Source Impedance

The power module should be connected to a low ac-impedance source. A highly inductive source impedance can affect the stability of the power module. For the test configuration in Figure 7, a 470μF Low ESR aluminum capacitor, CIN, mounted close to the power module helps ensure the stability of the unit. Consult the factory for further application guidelines

Output Capacitance

The JNW350R power module requires a minimum output capacitance of 440μF Low ESR aluminum capacitor, Cout to ensure stable operation over the full range of load and line conditions, see Figure 8. If the ambient temperature is under -20C, it is required to use at least 3 pcs of minimum capacitors in parallel. In general, the process of determining the acceptable values of output capacitance and ESR is complex and is load-dependant.

Safety Considerations

For safety-agency approval of the system in which the power module is used, the power module must be installed in compliance with the spacing and separation requirements of the end-use safety agency standard, i.e., UL60950-1, CSA C22.2 No. 60950-1-03, EN60950-1 and VDE 0805:2001-12.

For end products connected to -48V dc, or -60Vdc nominal DC MAINS (i.e. central office dc battery plant), no further fault testing is required. *Note: -60V dc nominal battery plants are not available in the U.S. or Canada.

For all input voltages, other than DC MAINS, where the input voltage is less than 60V dc, if the input meets all of the requirements for SELV, then:

- The output may be considered SELV. Output voltages will remain within SELV limits even with internally-generated non-SELV voltages. Single component failure and fault tests were performed in the power converters.
- One pole of the input and one pole of the output are to be grounded, or both circuits are to be kept floating, to maintain the output voltage to ground voltage within ELV or SELV limits. However, SELV will not be maintained if Vi(+) and Vo(+) are grounded simultaneously.

JNW350R Power Modules; DC-DC Converters

36 – 75 Vdc Input; 28Vdc Output; 350W Output

Safety Considerations (continued)

For all input sources, other than DC MAINS, where the input voltage is between 60 and 75V dc (Classified as TNV-2 in Europe), the following must be met, if the converter's output is to be evaluated for SELV:

- The input source is to be provided with reinforced insulation from any hazardous voltage, including the ac mains.
- One V_i pin and one V_o pin are to be reliably earthed, or both the input and output pins are to be kept floating.
- Another SELV reliability test is conducted on the whole system, as required by the safety agencies, on the combination of supply source and the subject module to verify that under a single fault, hazardous voltages do not appear at the module's output.

All flammable materials used in the manufacturing of these modules are rated 94V-0, or tested to the UL60950 A.2 for reduced thickness.

The input to these units is to be provided with a maximum 20 A fast-acting or time-delay fuse in the unearthed lead.

Feature Description

Remote On/Off

Two remote on/off options are available. Positive logic turns the module on during a logic high voltage on the ON/OFF pin, and off during a logic low. Negative logic remote On/Off, device code suffix "1", turns the module off during a logic high and on during a logic low.

To turn the power module on and off, the user must supply a switch (open collector or equivalent) to control the voltage ($V_{on/off}$) between the ON/OFF terminal and the $V_{IN(-)}$ terminal (see Figure 10). Logic low is $0V \leq V_{on/off} \leq 1.2V$. The maximum $I_{on/off}$ during a logic low is 1mA, the switch should be maintain a logic low level whilst sinking this current.

During a logic high, the typical maximum $V_{on/off}$ generated by the module is 5V, and the maximum allowable leakage current at $V_{on/off} = 5V$ is 50 μ A.

If not using the remote on/off feature:

For positive logic, leave the ON/OFF pin open.

For negative logic, short the ON/OFF pin to $V_{IN(-)}$.

Over-Current Protection (OCP)

To provide protection in a fault output overload

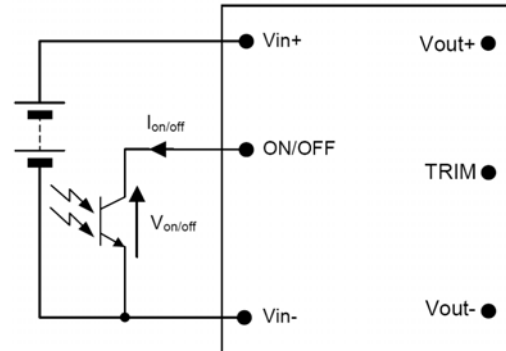

Figure 10. Circuit configuration for using Remote On/Off Implementation.

condition, the module is equipped with internal current limiting protection circuitry, and can endure over-current transient overloads depending upon the duration and amplitude of the overload. An internal buffer measures the relative product of the duration and amplitude of the overload and allows operation until a limit threshold is reached. For lower amplitude overloads, the module will operate without shutdown for a longer transient overload. If the overload amplitude is larger, the module will reach shutdown in a shorter period of time.

A latching shutdown option is standard. If over-current persists for beyond the overload buffer, the module will shut down and remain off until the module is reset by either cycling the input power or by toggling the on/off pin for one second.

An OCP auto-restart option (code = 3 or 4, see Table 2) is also available in a case where an auto recovery is required. Once the module has shutdown, after a period of several 100's of milliseconds, the module will restart. If the output overload condition still exists when the module restarts, it will shut down again. This operation will continue indefinitely, until the over-current condition is corrected.

Over-Voltage Protection (OVP)

The output over-voltage protection consists of circuitry that monitors the voltage on the output terminals. If the voltage on the output terminals exceeds the over voltage protection threshold, then the module will shutdown and latch off. The over-voltage latch is reset by either cycling the input power for one second or by toggling the on/off signal for one second. The protection mechanism is such that the unit can continue in this condition until the fault is cleared.

An OVP auto-restart option (code = 3, see Table 2) is also available in a case where an auto recovery is required. Once the module has shutdown, after a period of several 100's of milliseconds, the module will restart. If the output overload condition still exists when the module restarts, it will shut down again. This operation will continue indefinitely, until the over-current condition is corrected.

JNW350R Power Modules; DC-DC Converters

36 – 75 Vdc Input; 28Vdc Output; 350W Output

Feature Description (continued)

Remote sense

Remote sense minimizes the effects of distribution losses by regulating the voltage at the remote-sense connection (see Figure 11). For No Trim or Trim down application, the voltage between the remote-sense pin and the output terminal must not exceed the output voltage sense range given in the Feature Specifications table i.e.: $SENSE(+)-V_o(+)\leq 2\%$ of $V_{o,nom}$.

The voltage between the $V_o(+)$ and $V_o(-)$ terminals must not exceed the minimum output over-voltage shut-down value indicated in the Feature Specifications table. This limit includes any increase in voltage due to remote-sense compensation and output voltage set-point adjustment (trim). See Figure 11. Do not connect $SENSE(-)$ to the $V_o(-)$ or $R_{load}(-)$ as there is a 0Ω connection internal to the module. If not using the remote-sense feature to regulate the output at the point of load, then connect $SENSE(+)$ to $V_o(+)$.

Although the output voltage can be increased by both the remote sense and by the trim, the maximum increase for the output voltage is not the sum of both. The maximum increase is the larger of either the remote sense or the trim. The amount of power delivered by the module is defined as the voltage at the output terminals multiplied by the output current. When using remote sense and trim: the output voltage of the module can be increased, which at the same output current would increase the power output of the module. Care should be taken to ensure that the maximum output power of the module remains at or below the maximum rated power.

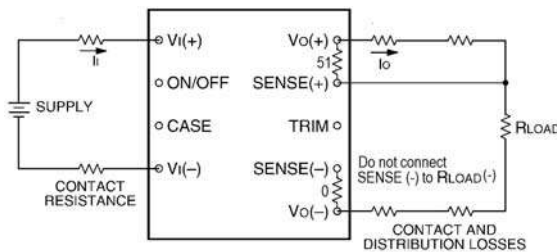

Figure 11. Effective Circuit Configuration for Single-Module Remote-Sense Operation Output Voltage.

Output Voltage Programming

Trimming allows the user to increase or decrease the output voltage set point of a module. The trim resistor should be positioned close to the module. Certain restrictions apply to the input voltage lower limit when trimming the output voltage to the maximum. See Figure 12 for the allowed input to output range when using trim. If not using the trim down feature, leave the TRIM pin open.

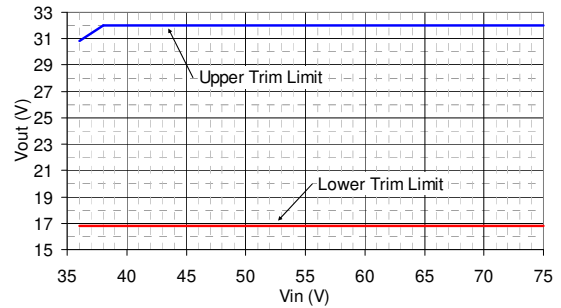

Figure 12. Output voltage trim limits vs. Input Voltage. Modules without the -T Option

Trim Down – Decrease Output Voltage

Trimming down is accomplished by connecting an external resistor between the TRIM pin and the $SENSE(-)$ pin. With an external resistor ($R_{adj-down}$) between the TRIM and $SENSE(-)$ pins, the output voltage set point ($V_{o,adj}$) decreases (see Figure 13). The following equation determines the required external-resistor value to obtain a percentage output voltage change of $\Delta\%$.

For output voltages: 28V

$$R_{adj-down} = \left(\frac{100}{\Delta\%} - 2 \right) k\Omega$$

Where,

$$\Delta\% = \left| \frac{V_{o,nom} - V_{desired}}{V_{o,nom}} \right| \times 100$$

$V_{desired}$ = Desired output voltage set point (V).

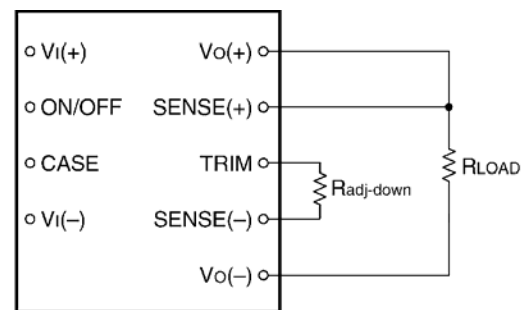

Figure 13. Circuit Configuration to Decrease Output Voltage, Standard JNW350R.

Trim Up – Increase Output Voltage

Trimming up is accomplished by connecting external resistor between the $SENSE(+)$ pin and TRIM pin. With an external resistor (R_{adj-up}) connected between the $SENSE(+)$ and TRIM pins, the output voltage set point ($V_{o,adj}$) increases (see Figure 14).

JNW350R Power Modules; DC-DC Converters

36 – 75 Vdc Input; 28Vdc Output; 350W Output

Feature Description (continued)

The following equation determines the required external-resistor value to obtain a percentage output voltage change of $\Delta\%$.

For output voltages: 28V

$$R_{adj-up} = \left[\frac{V_{o,nom} \times (100 + \Delta\%)}{1.225 \times \Delta\%} - \frac{(100 + (2 \times \Delta\%))}{\Delta\%} \right] k\Omega$$

Where,

$$\Delta\% = \left| \frac{V_{desired} - V_{o,nom}}{V_{o,nom}} \right| \times 100$$

$V_{desired}$ = Desired output voltage set point (V).

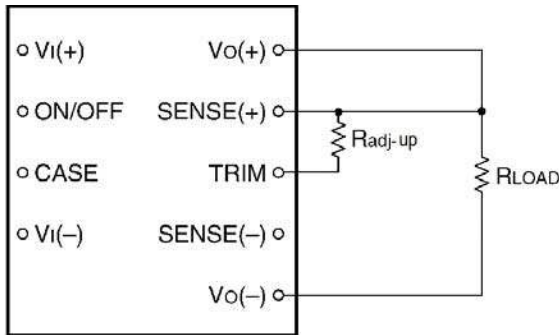

Figure 14. Circuit Configuration to Increase Output Voltage, Standard JNW350R.

Examples:

To trim down the output of a nominal 28V module to 16.8V

$$\Delta\% = \left| \frac{28V - 16.8V}{28V} \right| \times 100$$

$\Delta\% = 40$

$$R_{adj-down} = \left(\frac{100}{40} - 2 \right) k\Omega$$

$R_{adj-down} = 0.5 k$

To trim up the output of a nominal 28V module to 30.8V

$$\Delta\% = \left| \frac{30.8V - 28V}{28V} \right| \times 100$$

$\Delta\% = 10$

$$R_{adj-up} = \left[\frac{28 \times (100 + 10)}{1.225 \times 10} - \frac{(100 + (2 \times 10))}{10} \right] k\Omega$$

$R_{adj-up} = 239.4 k\Omega$

Modules with the -T Option

Trim Down – Decrease Output Voltage

With an external resistor ($R_{adj-down}$) between the TRIM and SENSE(+) pins, the output voltage set point ($V_{o,adj}$) decreases (see Figure 15). The following equation determines the required external-resistor value to obtain a percentage output voltage change of $\Delta\%$.

For output voltages: 28V

$$R_{adj-down} = \left(\frac{10631.45}{\Delta\%} - 111.2 \right) k\Omega$$

Where,

$$\Delta\% = \left| \frac{V_{o,nom} - V_{desired}}{V_{o,nom}} \right| \times 100$$

$V_{desired}$ = Desired output voltage set point (V).

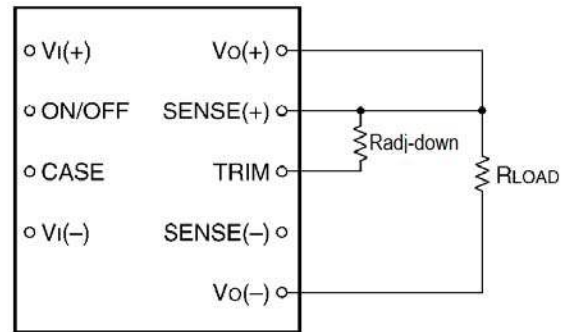

Figure 15. Circuit Configuration to Decrease Output Voltage, JNW350R-T option.

Trim Up – Increase Output Voltage

With an external resistor (R_{adj-up}) connected between the SENSE(-) and TRIM pins, the output voltage set point ($V_{o,adj}$) increases (see Figure 16).

The following equation determines the required external-resistor value to obtain a percentage output voltage change of $\Delta\%$.

For output voltages: 28V

$$R_{adj-up} = \left(\frac{488.5}{\Delta\%} \right) k\Omega$$

Where,

$$\Delta\% = \left| \frac{V_{desired} - V_{o,nom}}{V_{o,nom}} \right| \times 100$$

$V_{desired}$ = Desired output voltage set point (V).

JNW350R Power Modules; DC-DC Converters

36 – 75 Vdc Input; 28Vdc Output; 350W Output

Feature Description (continued)

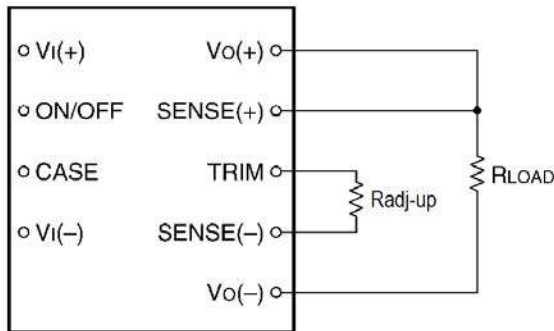

Figure 16. Circuit Configuration to Increase Output Voltage, JNW350Rx-T option.

Examples:

To trim down the output of a nominal 28V JNW350-T module to 16.8V

$$\Delta\% = \left| \frac{28V - 16.8V}{28V} \right| \times 100$$

$\Delta\% = 40$

$$R_{adj-down} = \left(\frac{10631.45}{40} - 111.2 \right) k\Omega$$

$R_{adj-down} = 154.5 k$

To trim up the output of a nominal 28V JNW350-T module to 30.8V

$$\Delta\% = \left| \frac{30.8V - 28V}{28V} \right| \times 100$$

$\Delta\% = 10$

$$R_{adj-up} = \left(\frac{488.5}{10} \right) k\Omega$$

$R_{adj-up} = 48.8 k\Omega$

Active Voltage Programming

For both the JNW350Rx and JNW350Rx-T, a Digital-Analog converter (DAC), capable of both sourcing and sinking current, can be used to actively set the output voltage, as shown in Figure 17. The value of R_G will be dependent on the voltage step and range of the DAC and the desired values for trim-up and trim-down $\Delta\%$. Please contact your GE technical representative to obtain more details on the selection for this resistor.

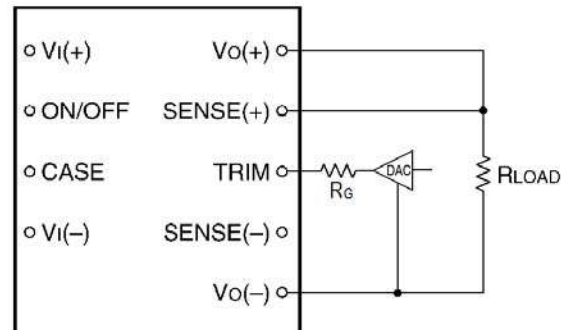

Figure 17. Circuit Configuration to Actively Adjust the Output Voltage.

Tunable Loop™

The JNW350Rx-T modules have a new feature that optimizes transient response of the module called Tunable Loop™.

External capacitors are usually added to the output of the module for two reasons: to reduce output ripple and noise and to reduce output voltage deviations from the steady-state value in the presence of dynamic load current changes. Adding external capacitance however affects the voltage control loop of the module, typically causing the loop to slow down with sluggish response. Larger values of external capacitance could also cause the module to become unstable.

The Tunable Loop™ allows the user to externally adjust the voltage control loop to match the filter network connected to the output of the module. The Tunable Loop™ is implemented by connecting a series R-C between the SENSE(+) and TRIM pins of the module, as shown in Fig. 48. This R-C allows the user to externally adjust the voltage loop feedback compensation of the module.

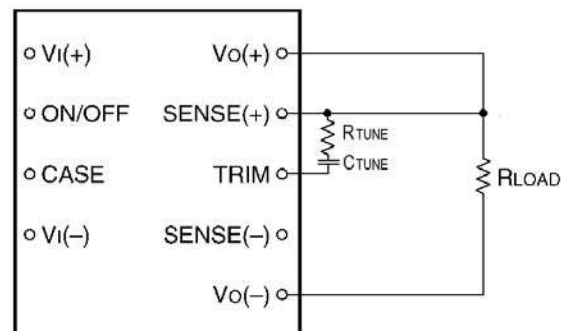

Figure 18. Circuit diagram showing connection of R_{TUNE} and C_{TUNE} to tune the control loop of the module.

Recommended values of R_{TUNE} and C_{TUNE} for different output capacitor combinations are given in Tables 1 and 2. Table 1 shows the recommended values of R_{TUNE} and C_{TUNE} for different values of ceramic output capacitors up to 8000 F that might be needed for an application to

JNW350R Power Modules; DC-DC Converters 36 – 75 Vdc Input; 28Vdc Output; 350W Output

meet output ripple and noise requirements. Selecting R_{TUNE} and C_{TUNE} according to Table 2 will ensure stable operation of the module

In applications with tight output voltage limits in the presence of dynamic current loading, additional output capacitance will be required. Table 2 lists recommended values of R_{TUNE} and C_{TUNE} in order to meet 2% output voltage deviation limits for some common output voltages in the presence of a 6A to 12A step change (50% of full load), with an input voltage of 48V.

Table 1. General recommended values of R_{TUNE} and C_{TUNE} for $V_{out}=28V$ and various external ceramic capacitor combinations.

$C_{out}(\mu F)$	1100	2200	4400	6600	8000
$R_{TUNE}(k)$	348	200	51.1	36.5	40.2
$C_{TUNE}(pF)$	1500	6800	10,000	15,000	15,000

Table 2. Recommended values of R_{TUNE} and C_{TUNE} to obtain transient deviation of 2% of V_{out} for a 6A step load with $V_{in}=48V$.

V_o	32V	28V	25V	22V	19V	16.8V
$C_o(\mu F)$	880	880	1100	1320	1320	1540
$R_{TUNE}(k)$	1000	402	348	221	84.5	61.9
$C_{TUNE}(pF)$	820	1500	1500	2200	3300	6800
$\Delta V(mV)$	530	500	530	420	370	317

Please contact your GE technical representative to obtain more details of this feature as well as for guidelines on how to select the right value of external R-C to tune the module for best transient performance and stable operation for other output capacitance values.

Over Temperature Protection

The JNW350R module provides with non-latching over temperature protection. A temperature sensor monitors the operating temperature of the converter. If the reference temperature exceeds a threshold of 110 °C (typical) at the center of the baseplate, the converter will shut down and disable the output. When the baseplate temperature has decreased by approximately 20 °C the converter will automatically restart.

Thermal Considerations

The power modules operate in a variety of thermal environments; however, sufficient cooling should be provided to help ensure reliable operation of the unit. Heat-dissipating components inside the unit are thermally coupled to the case. Heat is removed by conduction, convection, and radiation to the surrounding environment. Proper cooling can be verified by measuring the case temperature. Peak temperature (T_{REF}) occurs at the position indicated in Figure 15.

Considerations include ambient temperature, airflow, module power dissipation, and the need for increased reliability. A reduction in the operating temperature of the module will result in an increase in reliability. The thermal data presented here is based on physical measurements taken in a wind tunnel.

For reliable operation this temperature should not exceed 100°C at $T_{REF 1}$ for cold plate applications or exceed 112°C at $T_{REF 2}$ for applications using forced convection airflow. The output power of the module should not exceed the rated power for the module as listed in the ordering information table. Although the maximum T_{REF} temperature of the power modules is discussed above, you can limit this temperature to a lower value for extremely high reliability.

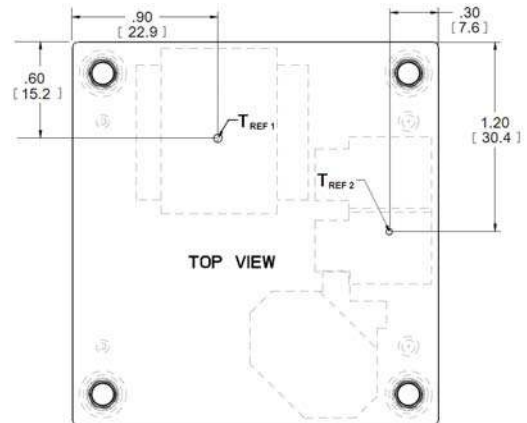

Figure 19. Case (T_{REF}) Temperature Measurement Location (top view).

Thermal Derating

Thermal derating is presented for two different applications: 1) Figure 20, the JNW350R module is thermally coupled to a cold plate inside a sealed clamshell chassis, without any internal air circulation; and 2) Figure 21 and 22, the JNW350R module is mounted in a traditional open chassis or cards with forced air flow. In application 1, the module is cooled entirely by conduction of heat from the module primarily through the top surface to a coldplate, with some conduction through the module's pins to the power layers in the system board. For application 2, the module is cooled by heat removal into a forced airflow that passes through the interior of the module and over the top baseplate and/or attached heatsink.

JNW350R Power Modules; DC-DC Converters

36 – 75 Vdc Input; 28Vdc Output; 350W Output

Thermal Considerations (continued)

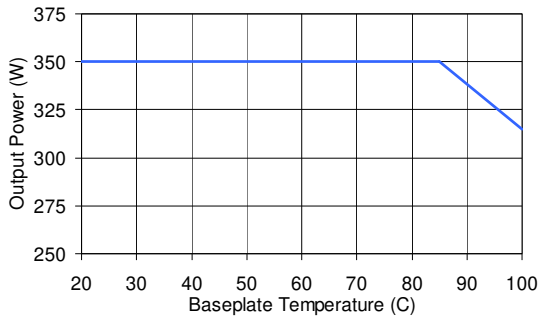

Figure 20. Output Power Derating for JNW350R in Conduction cooling (cold plate) applications; $T_0 < 70^\circ\text{C}$ in vicinity of module interior; $V_{IN} = V_{IN, NOM}$

Layout Considerations

The JNW350R power module series are aluminum base board packaged style, as such; component clearance between the bottom of the power module and the mounting (Host) board is limited. Avoid placing copper areas on the outer layer directly underneath the power module.

Post Solder Cleaning and Drying Considerations

Post solder cleaning is usually the final circuit-board assembly process prior to electrical board testing. The result of inadequate cleaning and drying can affect both the reliability of a power module and the testability of the finished circuit-board assembly. For guidance on appropriate soldering, cleaning and drying procedures, refer to GE Board Mounted Power Modules: Soldering and Cleaning Application Note.

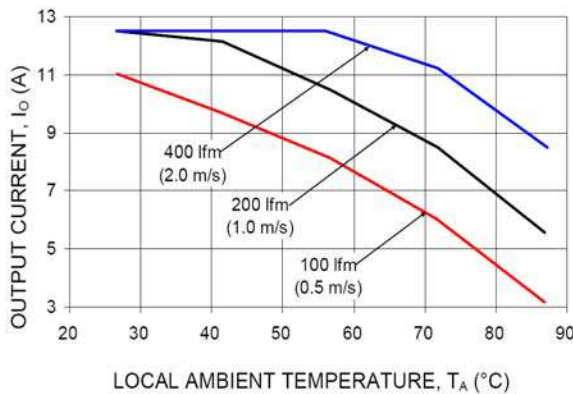

Figure 21. Derating Output Current vs. local Ambient temperature and Airflow, No Heatsink, $V_{in}=48\text{V}$.

Through-Hole Lead-Free Soldering Information

The RoHS-compliant through-hole products use the SAC (Sn/Ag/Cu) Pb-free solder and RoHS-compliant components. They are designed to be processed through single or dual wave soldering machines. The pins have an RoHS-compliant finish that is compatible with both Pb and Pb-free wave soldering processes. A maximum preheat rate of 3°C/s is suggested. The wave preheat process should be such that the temperature of the power module board is kept below 210°C . For Pb solder, the recommended pot temperature is 260°C , while the Pb-free solder pot is 270°C max. Not all RoHS-compliant through-hole products can be processed with paste-through-hole Pb or Pb-free reflow process. If additional information is needed, please consult with your GE representative for more details.

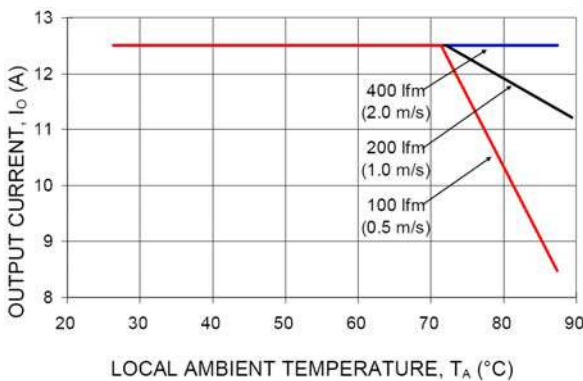

Figure 22. Derating Output Current vs. local Ambient temperature and Airflow, 1" Heatsink, $V_{in}=48\text{V}$.

JNW350R Power Modules; DC-DC Converters 36 – 75 Vdc Input; 28Vdc Output; 350W Output

EMC Considerations

The filter circuit schematic and plots in Figure 23 shows a suggested configuration as tested to meet the conducted emission limits of EN55022 Class B.

Note: Customer is ultimately responsible for the proper selection, component rating and verification of the suggested parts based on the end application.

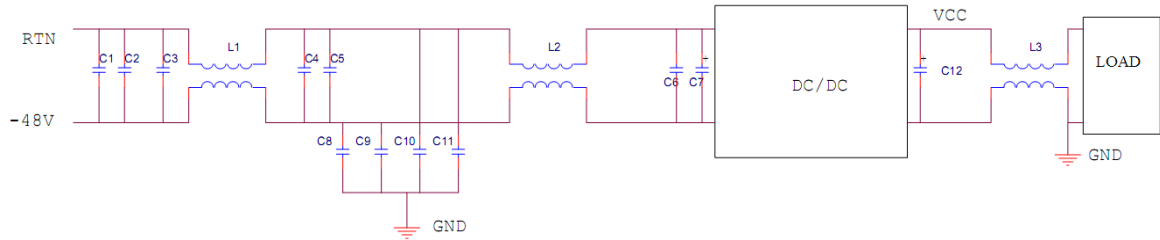

Symbol	Component Description
C1 – C5	SMD Ceramic Capacitor: 1000nF/100V/X7R/1210
C6	SMD Ceramic Capacitor : 100nF/100V/X7R/1206
L1, L2	CM inductor-single phase: 473uH-14A-R5K-1*25.4*12.7mm
C8 – C11	SMD Ceramic Capacitor: 0.22uF/630V/X7R/2220, meet 1kV endure voltage requirement.
C7	Electrolytic capacitor: 470uF, 100V
C12	Electrolytic capacitor: 470uF, 35V
L3	CM inductor-single phase core: 17uH- R7K-25*15*12; winding: 5TS

Figure 23. EMC Filter

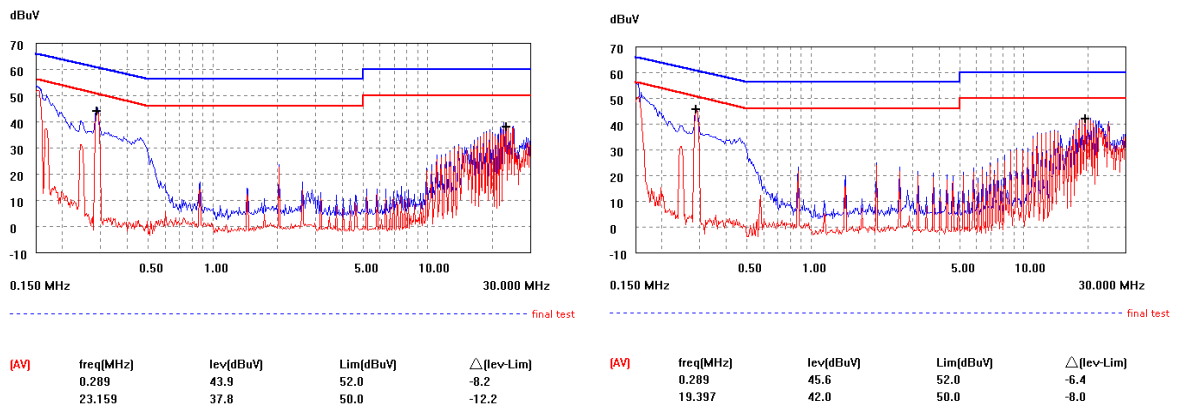

For further information on designing for EMC compliance, please refer to the FLTR100V20 data sheet (FDS01-077EPS).

JNW350R Power Modules; DC-DC Converters 36 – 75 Vdc Input; 28Vdc Output; 350W Output

Mechanical Outline for Through-Hole Module

Dimensions are in inches and [millimeters].

Tolerances: x.xx in. ± 0.02 in. [x.x mm ± 0.5 mm] (Unless otherwise indicated)

x.xxx in ± 0.010 in. [x.xx mm ± 0.25 mm]

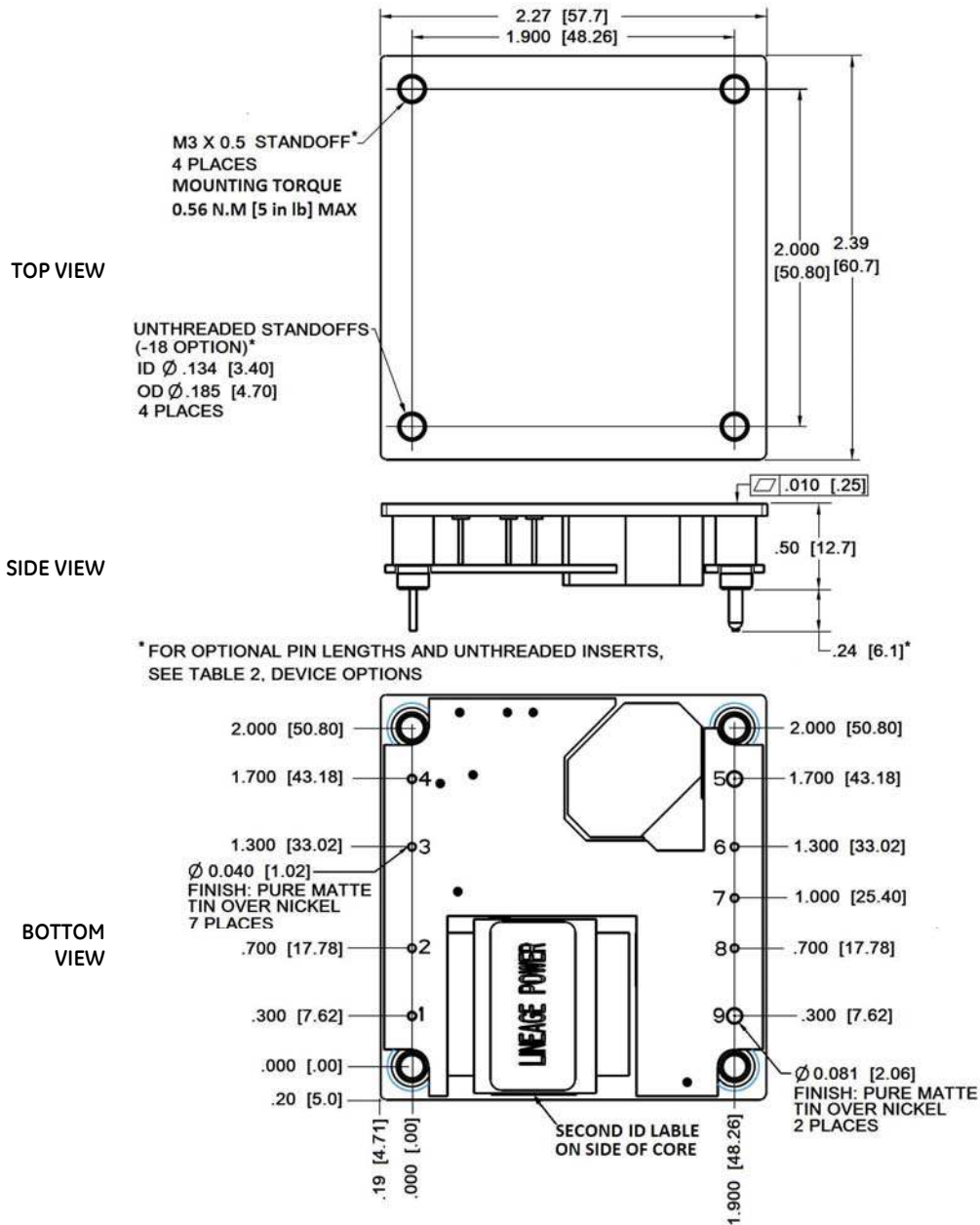

Pin	Description	Pin	Description	Pin	Description
1	Vin (+)	4	Vin (-)	7	Trim
2	On/Off	5	Vout (-)	8	Sense (+)
3	Baseplate	6	Sense (-)	9	Vout (+)

JNW350R Power Modules; DC-DC Converters

36 – 75 Vdc Input; 28Vdc Output; 350W Output

Recommended Pad Layout for Through Hole Module

Dimensions are in inches and [millimeters].

Tolerances: x.xx in. ± 0.02 in. [x.x mm ± 0.5 mm] (Unless otherwise indicated)

x.xxx in ± 0.010 in. [x.xx mm ± 0.25 mm]

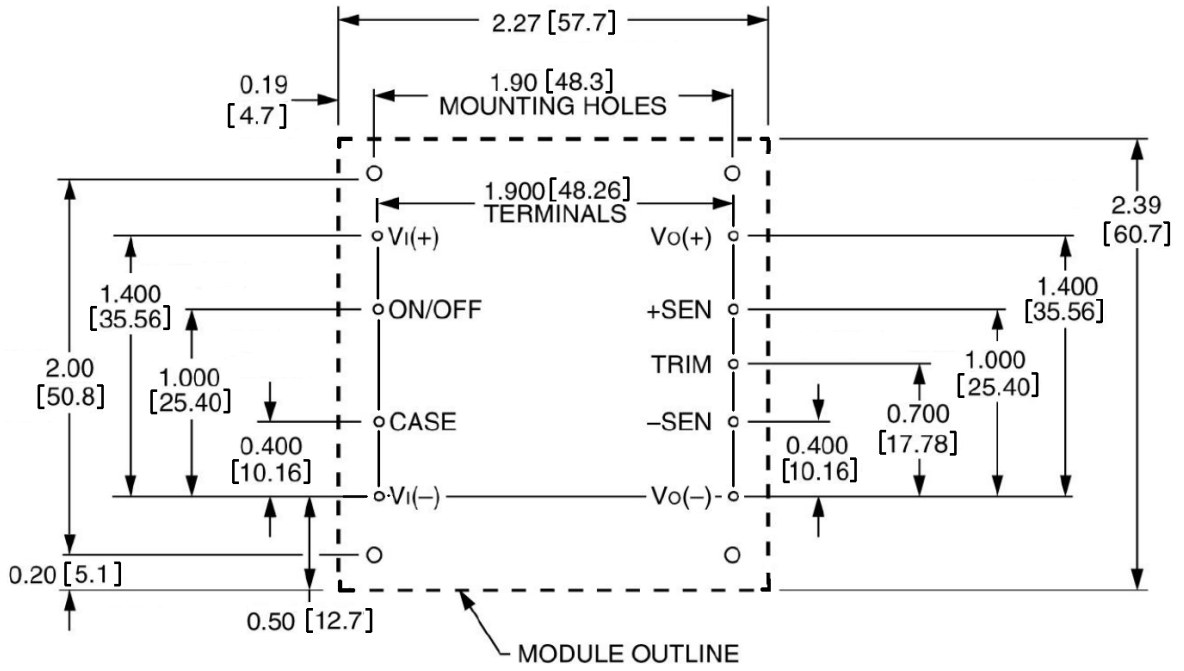

JNW350R Power Modules; DC-DC Converters
36 – 75 Vdc Input; 28Vdc Output; 350W Output

Ordering Information

Table 1. Device Code

Input Voltage	Output Voltage	Output Current	Efficiency	Connector Type	Product codes	Comcodes
48V (36-75Vdc)	28V	12.5A	92%	Through hole	JNW350R631-18Z	CC109161931
48V (36-75Vdc)	28V	12.5A	92%	Through hole	JNW350R41-18TZ	CC109150083
48V (36-75Vdc)	28V	12.5A	92%	Through hole	JNW350R641	CC109147476
48V (36-75Vdc)	28V	12.5A	92%	Through hole	JNW350R641Z	CC109148623
48V (36-75Vdc)	28V	12.5A	92%	Through hole	JNW350R641-18	CC109147451
48V (36-75Vdc)	28V	12.5A	92%	Through hole	JNW350R641-TZ	CC109149836
48V (36-75Vdc)	28V	12.5A	92%	Through hole	JNW350R64-18Z	CC109161361
48V (36-75Vdc)	28V	12.5A	92%	Through hole	JNW350R641-18Z	CC109149712
48V (36-75Vdc)	28V	12.5A	92%	Through hole	JNW350R841-18TZ	CC109153672

Table 2. Device Options

	Characteristic	Character and Position	Definition
Ratings	Form Factor	J	J = Half Brick
	Family Designator	N	
	Input Voltage	W	W = Wide Range, 36V-75V
	Output Power	350	350 = 350 Watts Maximum Output Power
	Output Voltage	R	R = 28.0V nominal
	Pin Length	6 8	Omit = Default Pin Length shown in Mechanical Outline Figures 6 = Pin Length: 3.68 mm ± 0.25mm, (0.145 in. ± 0.010 in.) 8 = Pin Length: 2.79 mm ± 0.25mm, (0.110 in. ± 0.010 in.)
Options	Action following Output Protective Shutdown	3 4	Omit = Latching Mode following either Over-Voltage Protection (OVP) or Over-Current Protection (OCP) shutdown 3 = Auto-restart Mode following either Over-Voltage Protection (OVP) or Over-Current Protection (OCP) shutdown 4 = Auto-restart Mode following Over-Current Protection (OCP) shutdown and Latching Mode following Over-Voltage Protection (OVP) shutdown
	On/Off Logic	1	Omit = Positive Logic 1 = Negative Logic
	Customer Specific	XY	XY = Customer Specific Modified Code, Omit for Standard Code
	Mechanical Features	18	Omit = Standard open Frame Module 18= Unthreaded heat sink inserts
	Tunable Loop™	T	Internal compensation network optimized for Tunable Loop™ applications
	RoHS	Z	Omit = RoHS 5/6, Lead Based Solder Used Z = RoHS 6/6 Compliant, Lead free

Contact Us

For more information, call us at

USA/Canada:

+1 877 546 3243, or +1 972 244 9288

Asia-Pacific:

+86.021.54279977*808

Europe, Middle-East and Africa:

+49.89.878067-280



www.gecriticalpower.com

GE Critical Power reserves the right to make changes to the product(s) or information contained herein without notice, and no liability is assumed as a result of their use or application. No rights under any patent accompany the sale of any such product(s) or information.