

CODE	DIM "M" MATING LENGTH	CONTACT TYPE
U	[6.86]	SIGNAL
R	[6.86]	SIGNAL
PA	[N/A]	POWER
HA	[N/A]	HOLD-DOWN
X	OMITTED	OMITTED

spec ref	*	dr	Ruan MT	2014/07/14	projection 	MM ←→	size	A4	scale	1:1
tolerance std	ASME Y14.5	eng	Ruan MT	2014/07/29			ecn no	-		
TOLERANCES UNLESS OTHERWISE SPECIFIED		chr	-	-			rel level	Released		
surface	✓	appr	Pei-Ming Zheng	2014/07/29	product family	PwrBlade	rev	A		
ASME Y14.5	linear	0.X	±0.5	www.fci.com	title	4ACP+16S+2ACP	dwg no	51939-906		
		0.XX	±0.25							
	0.XXX	±0.1								
	angular	0°	±2°	cat. no.	-	Product - Customer Drw	sheet 1 of 4			

PRODUCT NUMBER

51939-906--  
NOTE: 3

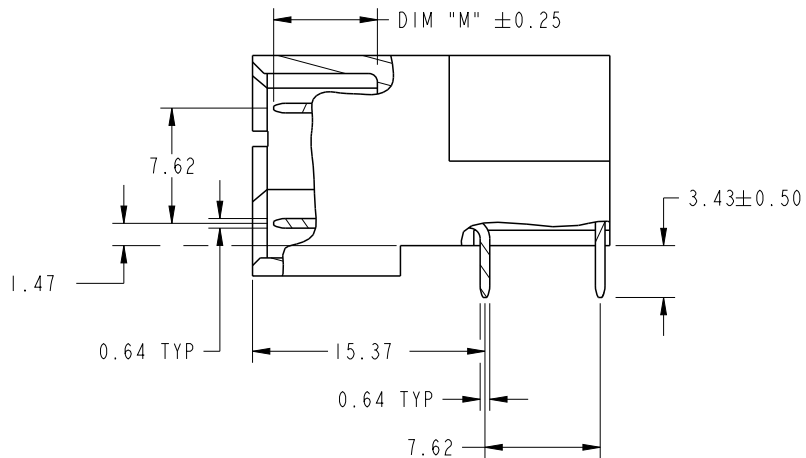

SECTION A-A  
SCALE 2:1

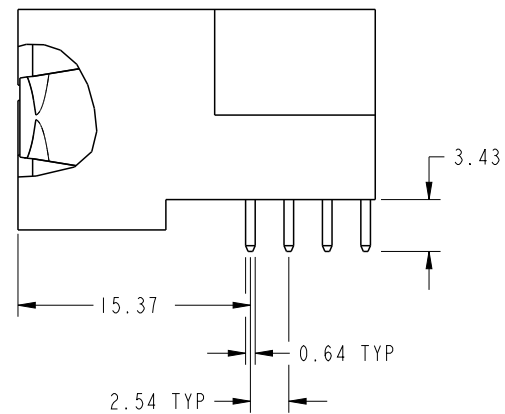

BROKEN-OUT SECTION B-B  
SCALE 2:1

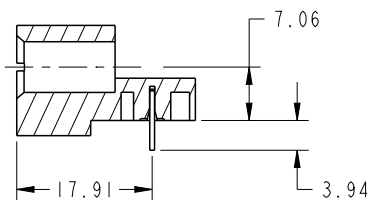

SECTION C-C

dr	Ruan MT	2014/07/14	projection 	MM 	size	A4	scale	1:1
eng	Ruan MT	2014/07/29			ecn no	-		
chr	-	-			rel level	Released		
appr	Pei-Ming Zheng	2014/07/29	product family	PwrBlade	rev	A		
	title	4ACP+16S+2ACP RIGHT ANGLE SOLDER HEADER		dwg no	51939-906			
www.fci.com	cat. no.	-	Product - Customer Drw	sheet 2 of 4				

PRODUCT NUMBER

51939-906\_\_  
NOTE: 3

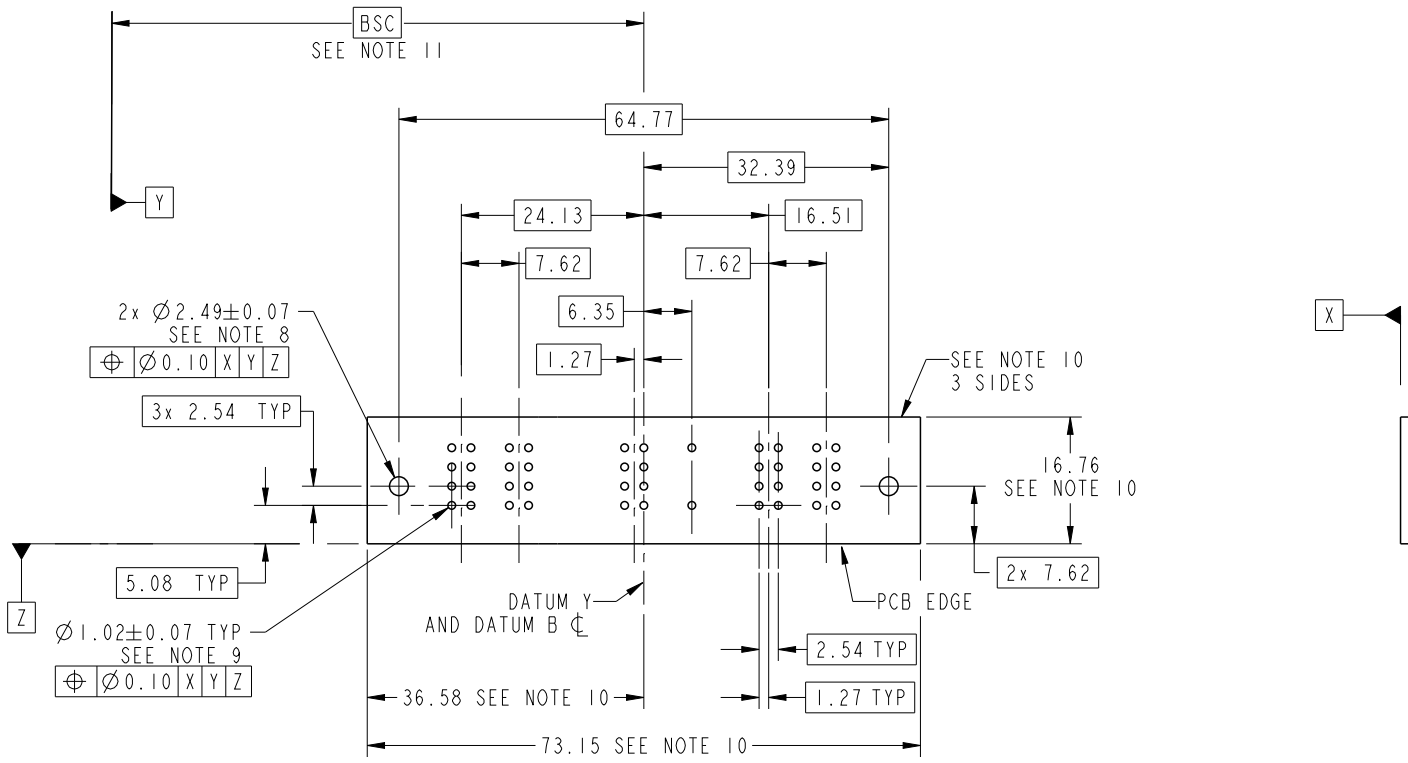

RECOMMENDED PCB LAYOUT

dr	Ruan MT	2014/07/14	projection 	MM 	size	A4	scale	1:1
eng	Ruan MT	2014/07/29			ecn no	-		
chr	-	-			rel level	Released		
appr	Pei-Ming Zheng	2014/07/29	product family	PwrBlade				
	title	4ACP+16S+2ACP RIGHT ANGLE SOLDER HEADER		dwg no	51939-906		rev	A
www.fci.com	cat. no.	-	Product - Customer Drw		sheet 3 of 4			

PRODUCT NUMBER

51939-906\_\_  
NOTE: 3

NOTES:

1. DIMENSIONS AND TOLERANCES ARE IN ACCORDANCE WITH ASME Y14.5M, 1994 UNLESS OTHERWISE SPECIFIED.

CONNECTOR NOTES:

- 2. HOUSING MATERIAL: UL 94 V-0 GLASS FILLED HIGH-TEMP THERMOPLASTIC  
POWER CONTACT MATERIAL: COPPER ALLOY  
SIGNAL PIN MATERIAL: COPPER ALLOY
- 3. SEE ITEM 1 & 2 IN PRINT 10064183 FOR PLATING SPEC OF 51939-906 AND 51939-906LF RESPECTIVELY.
- 4. MANUFACTURER'S NAME, DATE CODE AND OPTIONAL P/N TO APPEAR ON THIS SURFACE. THE MARK CAN BE OMITTED IF THERE IS NOT ENOUGH SPACE ON THIS SURFACE.
- 5. PRODUCT SPECIFICATION GS-12-149.  
APPLICATION SPECIFICATION BUS-20-067.
- 6. PACKAGED IN TRAYS.

PCB NOTES:

- 7. ALL HOLE DIAMETERS ARE FINISHED HOLE SIZE.
- 8. MOUNTING HOLES, WHERE APPLICABLE, ARE UNPLATED.
- 9.  $\varnothing 1.151 \pm 0.025$  DRILLED HOLES PLATED WITH  
0.008 MIN SnPb OR Sn OVER 0.03  
TO 0.08 Cu PLATING TO ACHIEVE  
 $\varnothing 1.02 \pm 0.07$  HOLE.
- 10. CONNECTOR KEEP-OUT ZONE.
- 11. DATUM AND BASIC DIMENSIONS ARE ESTABLISHED BY CUSTOMER.

dr	Ruan MT	2014/07/14	projection 	MM 	size	A4	scale	1:1	
eng	Ruan MT	2014/07/29			ecn no	-			
chr	-	-							
appr	Pei-Ming Zheng	2014/07/29	product family	PwrBlade	rel level	Released			
	title	4ACP+16S+2ACP RIGHT ANGLE SOLDER HEADER			dwg no	51939-906		rev	A
www.fci.com	cat. no.	-	Product - Customer Drw			sheet 4 of 4			



Copyright FCI.