

used for: D-SUB

No. of pos.	A ^{-0.76}	B ^{+0.25}	C	D ^{-0.3}	PART NO.
9	31.19	16.79	25.00 ^{+0.12} _{-0.13}	6.12	163A14439X
15	39.52	25.42	33.30 ^{+0.15} _{-0.16}	6.12	163A14440X
25	53.42	38.84	47.04 ^{+0.18} _{-0.19}	5.99	163A14459X
37	69.70	55.30	63.50 ^{+0.13} _{-0.14}	5.99	163A14469X

16K1A3718

16K1A3717

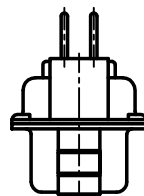
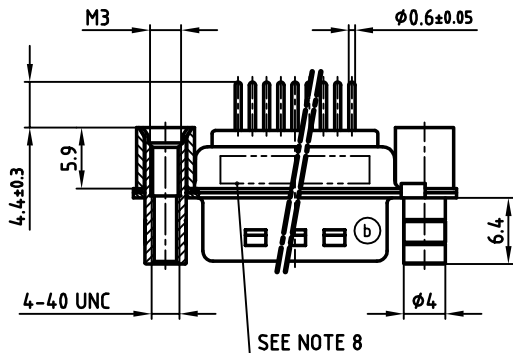
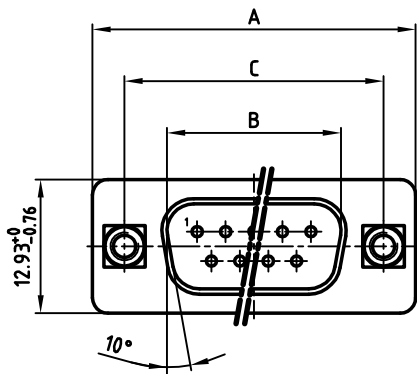
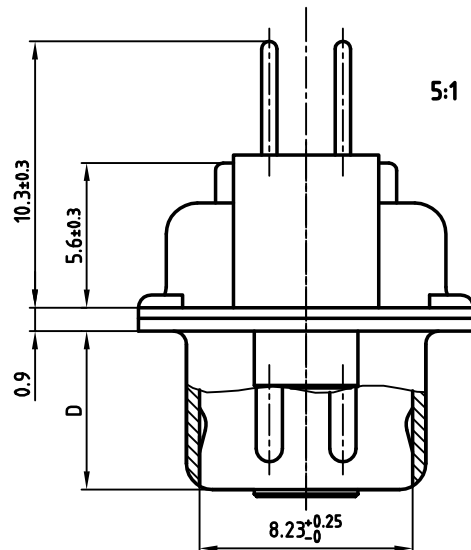

NOTES:

- METALSHELLS: STEEL; min. 315µin TIN over 40-80µin NICKEL
- INSULATORS: PBT GF UL 94 V-0, BLACK
- CONTACTS: COPPER ALLOY
PLATING: 8µin HARD GOLD over min. 50µin NICKEL
- THREADED REAR SPACER/FRONT THREADED LOCK: COPPER ALLOY; min. 200µin TIN over 80µin NICKEL
- SLEEVE: COPPER ALLOY; min. 200µin TIN over 80µin NICKEL
- P.C.B. HOLE DRILLINGS ON SHEET 2
- MAXIMUM TORQUE VALUE FOR THREAD: 6in. LB
- CONNECTOR IS PART MARKED: PART-NO. CONEC ABC

Directive 2002/95/EC
RoHS
Compliant

APPROVAL # FREIGABE # DEBLOCAGE # AUTORIZACION # APPROVAL	
CUSTOMER APPROVAL DATE:	
NAME:	TITLE:
COMPANY NAME:	
APPROVAL # FREIGABE # DEBLOCAGE # AUTORIZACION # APPROVAL	

THIS DRAWING MAY NOT BE COPIED OR REPRODUCED IN ANY WAY, AND MAY NOT BE PASSED ON TO A THIRD PARTY WITHOUT WRITTEN PERMISSION.
OWNERSHIP AND COPYRIGHT OF CONEC GmbH
DO NOT ALTER CAD DRAWING BY HAND

tolerance		dim. in mm	scale: 2:1 (5:1)	
material:			SEE NOTES	
2006	date	name		
drawn	07.02.	Lehmenkühler		
appd.	07.02.	Mickenbecker		
norm		DIN 41652		
d-old				
1 x b	Ä3721	18.08.2010	K.H.	
a	Origin			
rev.	description	date	name	



D-SUB MALE 9-37pos. SOLDER PIN STRAIGHT with threaded rear spacer, front threaded lock	
dwg no: AutoCAD 2004	
16K1A1729	
part no: SEE TABLE	
DIN-A	sh:1/2

9 pos.

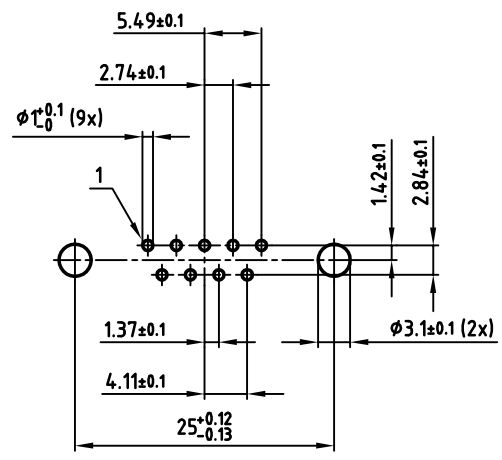

15 pos.

used for: D-SUB

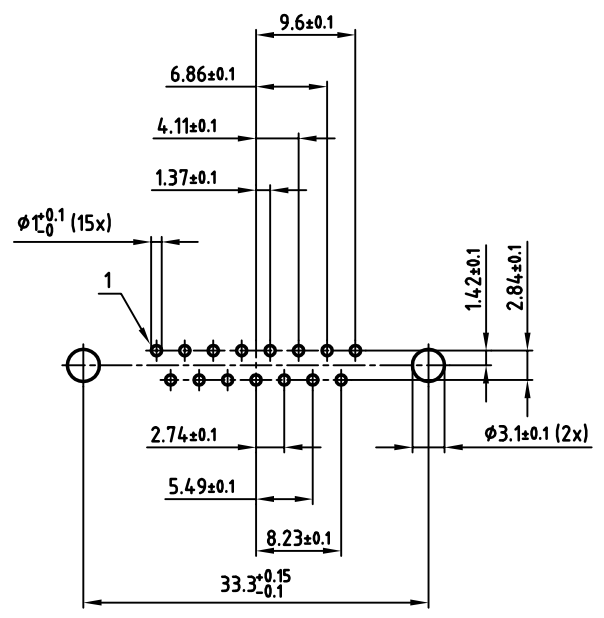

25 pos.

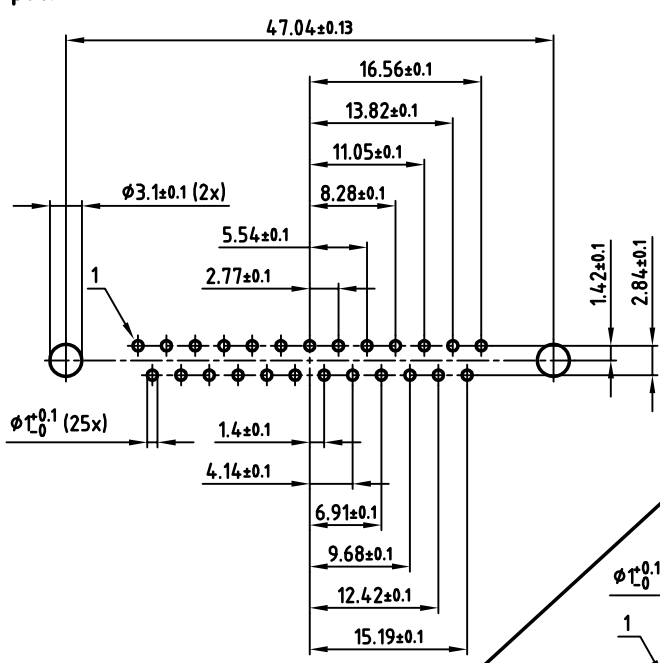

37 pos.

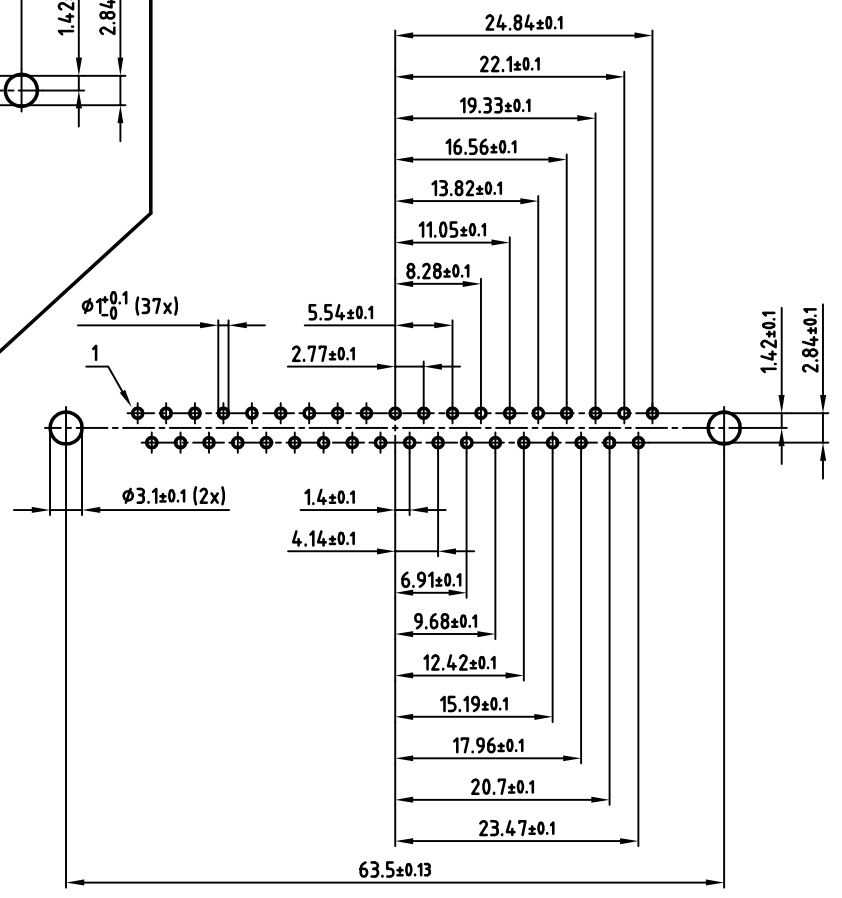

APPROVAL # FREIGABE # DEBLOCAGE # AUTORIZACION # APPROVAL

CUSTOMER APPROVAL DATE:

NAME: TITLE:

COMPANY NAME:

APPROVAL # FREIGABE # DEBLOCAGE # AUTORIZACION # APPROVAL

THIS DRAWING MAY NOT BE COPIED OR REPRODUCED IN ANY WAY, AND MAY NOT BE PASSED ON TO A THIRD PARTY WITHOUT WRITTEN PERMISSION. OWNERSHIP AND COPYRIGHT OF CONEC GMBH DO NOT ALTER CAD DRAWING BY HAND

tolerance			scale: 2:1	
dim. in mm			material: SEE SHEET 1	
2006	date	name		
drawn	07.02.	Lehmenkühler		
appd.	07.02.	Mickenbecker		
norm	DIN 41652			
d-old				
a	Origin			
rev.	description	date	name	

title: P.C.B. HOLE DRILLINGS

D-SUB MALE 9-37pos. SOLDER PIN with threaded rear spacer, front threaded lock

dwg no: AutoCAD 2004

16K1A1729

part no: SEE SHEET 1

DIN-A 3 sh:2/2

6

5

4

2

1