



CRYSTAL SPECIFICATION

Manufacturer: ECS Inc. International

Manufacturer P/N: ECS-320-CDX-2374

Customer:

Customer P/N:

Customer Approval :

ECS Inc. International

Tel: (913)-782-7787

Fax: (913)-782-6991

Website: www.ecsxtal.com

Sales: sales@ecsxtal.com

Engineering: engineering@ecsxtal.com

Date: 02-21-2023

Approved By: B. Slatten

Checked By: D. Kelly

Designer: A. Anderson



Rev.	Description of Revision History	Date	Designer	Checked By
1	New Publication	02-21-2023	A. Anderson	D. Kelly



CRYSTAL SPECIFICATION

1. Description : Quartz Crystal
2. Nominal Frequency : 32.0000000 MHz
3. Center Frequency : 32.0000000 MHz
4. Dimension & Drawing No. : ECX-1048B
5. Oscillation Mode : Fundamental
6. Cutting Mode : AT cut
7. Packing Style : Tape & Reel
8. Measurement Instrument : S&A 250B (Measured FL)
9. Electrical Characteristics :

[1] Operating Conditions:

Item	Symbol	MIN.	TYP.	MAX.	Unit	Condition
Operating Temperature Range	Topt	-20		70	°C	
Storage Temperature Range	Tstg	-40		105	°C	
Load Capacitance	CL		8		pF	
Drive Level	DL		50	200	μW	

[2] Frequency Stability:

Item	Symbol	MIN.	TYP.	MAX.	Unit	Condition
Tolerance	dF/Fo	-10		10	ppm	Refer to Center Frequency @25±3°C
Stability Over Temperature	dF/F25	-10		10	ppm	Refer to Operating Temperature
Aging	dF/F25	-2		2	ppm	First Year

dF/Fo: Frequency Deviation Refer to Center Frequency

dF/F25: Frequency Deviation Refer to 25 °C Frequency



[3] Electrical Performance :

Item	Symbol	MIN.	TYP.	MAX.	Unit	Condition
Equivalent Series Resistance	ESR			80	Ω	@Series
Shunt Capacitance	C0			3	pF	
Insulation Resistance	IR	500			M Ω	@DC 100 Volt

10. Marking : Laser

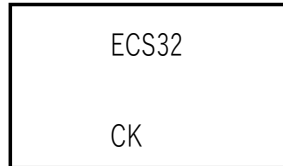

11. Remark :

*Compliant with EU RoHS 2015/863
* MSL 1

■Note

1. General cleaning solutions or ultrasonic cleaning method may be used to clean our products. However, under certain circumstances, ultrasonic cleaning machine could generate resonance at the oscillation frequency of our products and thus deteriorate the electrical characteristics in devices, and even damage the overall structure of devices. Therefore, verification test is recommended before cleaning.

2. Avoid mounting and processing by Ultrasonic welding this method has a possibility of an excessive vibration spreading inside the crystal products and becoming the cause of characteristic deterioration and not oscillating.

Dimensions: Top, Side and Bottom View
Unit: mm

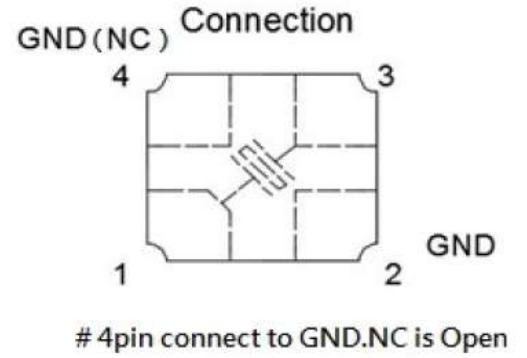
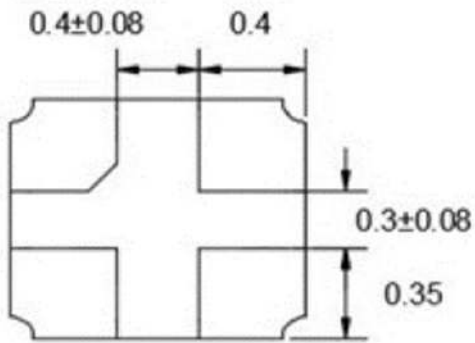
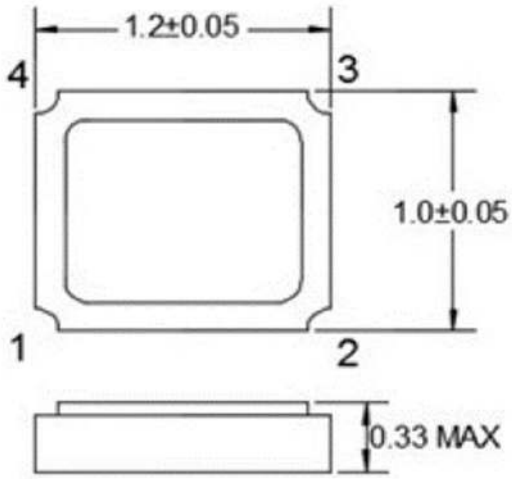

PAD CONNECTIONS	
1	In/Out
2	Gnd & Lid
3	Out/In
4	NC/Gnd

Land Pattern: (Reference)

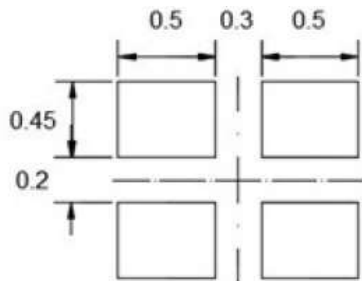



RELIABILITY SPECIFICATION

1. ENVIRONMENTAL PERFORMANCE

ITEM	CONDITION										
1. HIGH TEMPERATURE STORAGE	STORED AT 85±2°C FOR 1000±12H. (If Customer's temperature request is higher than the standard, Temperature test must be done for customer requirements.) THEN 25±2°C OVER 2H BEFORE TESTING.										
2. LOW TEMPERATURE STORAGE	STORED AT -40±2°C FOR 500±12H. (If Customer's temperature request is lower than the standard, Temperature test must be done for customer requirements.) THEN 25±2°C OVER 2H BEFORE TESTING.										
3. HIGH TEMP. & HUMIDITY	STORED AT 60 ± 2°C AND HUMIDITY 90~95% FOR 500 ± 12 H. THEN 25±2°C OVER 2H BEFORE TESTING.										
4. TEMPERATURE CYCLE	THE CRYSTAL UNIT SHALL BE SUBJECTED TO 1000 SUCCESSIVE CHANGE OF TEMPERATURE CYCLES, THEN 25 ± 2°C OVER 2 H BEFORE TESTING, EACH CYCLE AS BELLOW : <table border="0" style="margin-left: 40px;"> <thead> <tr> <th style="text-align: left;">TEMPERATURE</th> <th style="text-align: left;">DURATION</th> </tr> </thead> <tbody> <tr> <td>1. -40+0/-6°C</td> <td>30 ± 3 MINUTES</td> </tr> <tr> <td>2. 25°C ± 2°C</td> <td>2~3 MINUTES</td> </tr> <tr> <td>3. 125+4/-0°C</td> <td>30 ± 3 MINUTES</td> </tr> <tr> <td>4. 25°C ± 2°C</td> <td>2~3 MINUTES</td> </tr> </tbody> </table>	TEMPERATURE	DURATION	1. -40+0/-6°C	30 ± 3 MINUTES	2. 25°C ± 2°C	2~3 MINUTES	3. 125+4/-0°C	30 ± 3 MINUTES	4. 25°C ± 2°C	2~3 MINUTES
TEMPERATURE	DURATION										
1. -40+0/-6°C	30 ± 3 MINUTES										
2. 25°C ± 2°C	2~3 MINUTES										
3. 125+4/-0°C	30 ± 3 MINUTES										
4. 25°C ± 2°C	2~3 MINUTES										

2. MECHANICAL PERFORMANCE

ITEM	CONDITION
5. SOLDERABILITY	THE LEAD IS IMMERSSED IN A 260 ± 5°C SOLDER BATH WITHIN 2±0.6 SECONDS.
6. RESISTANCE TO SOLDERING HEAT	REFLOW CHART AS ATTACH SHEET. TWICE PASS.
7. FREE FALL	FREE DROPPING FROM 75 cm HEIGHT 3 TIMES ON A HARD WOODEN BOARD.
8. VIBRATION	FREQUENCY : 10~55Hz, AMPLITUDE (TOTAL EXCURSION) : 1.5mm ± 15%, SWEEP TIME : 1MIN, 3 DIRECTION(X, Y, Z) EACH FOR 2 Hrs.
9. GROSS LEAK	STANDARD SAMPLE FOR AUTOMATIC GROSS LEAK DETECTOR, TEST PRESSURE: 0.2 Mpa
10. FINE LEAK	HELIUM BOMBING 5.0~5.5 Kg _f / cm ² FOR 2 HOURS.

11. TERMINAL STRENGTH	SHALL BE PRESSURIZED AT A SPEED OF APPROX.0.5mm/sec IN THE DIRECTION INDICATED BY THE ARROW UNTIL THE BENDING WIDTH REACHES 3mm AND HELD FOR 5 SECONDS.
12. STICKING TENDENCY	A R0.5 JIG SHALL BE USED TO APPLY A 10N DEAD LOAD IN THE DIRECTION INDICATED BY THE ARROW TO THE ELEMENT AND RETAIN IT FOR 10 SECONDS.
13. ELEMENT ASSEMBLY STRENGTH	A R0.5 PRESSURIZED BAR SHALL BE USED TO APPLY A 10N LOAD IN THE CENTER OF ELEMENT AND RETAIN IT FOR 10 SECONDS.

◆ SUGGESTED REFLOW PROFILE

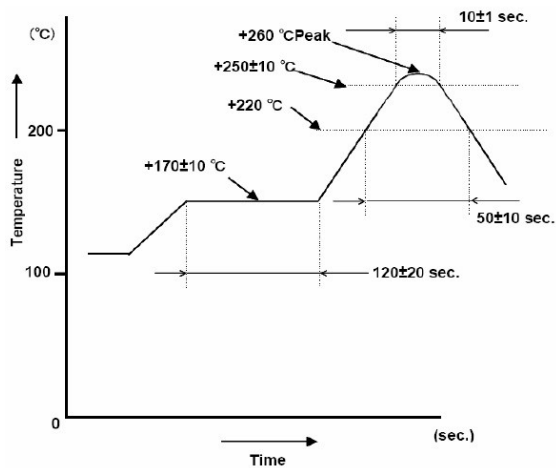

◆ PACKING

Unit: mm

1. CARRIER TYPE

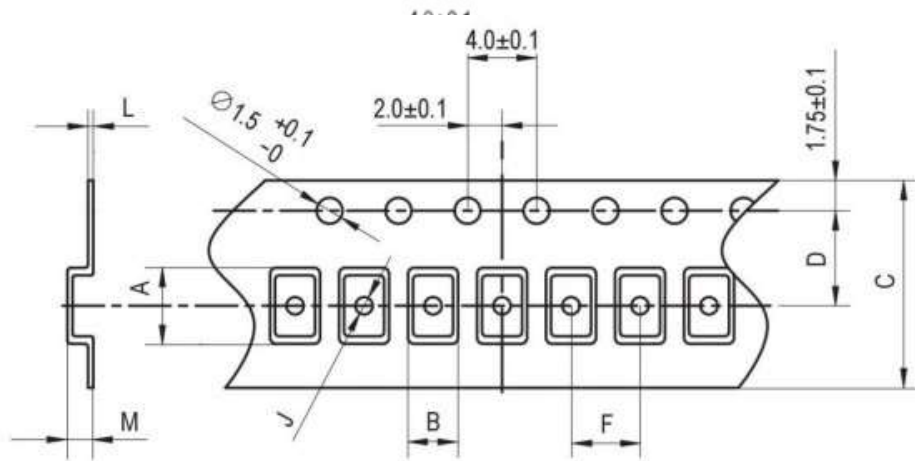

A	B	C	D	F	J	L	M	Reel Dia.
1.42	1.17	8.0	3.5	4.0	0.5	0.2	0.65	180