



MAX9515 Evaluation Kit

Evaluates: MAX9515

General Description

The MAX9515 evaluation kit (EV kit) is a fully assembled and tested surface-mount printed-circuit board (PCB) that evaluates the MAX9515 video filter amplifier IC. The MAX9515 features intelligent power management by disabling the filter and output amplifier in the absence of a video input signal and/or an output video load.

The MAX9515 features an internal reconstruction filter with a ± 1 dB passband flatness at 9MHz and 50dB of attenuation at 27MHz. The MAX9515 provides an internal fixed gain of 2V/V, accepts a full-scale video input signal of 1V_{P-P} (nominal) and provides an output full-scale video signal of 2V_{P-P} (nominal).

The MAX9515 EV kit video input and output are DC-coupled. The EV kit video input has 75 Ω termination to ground and the output has 75 Ω back termination. The EV kit operates from a single 2.7V to 3.6V DC power supply.

Component Supplier

SUPPLIER	PHONE	WEBSITE
TDK Corp.	847-803-6100	www.component.tdk.com

Note: Indicate that you are using the MAX9515 when contacting this component supplier.

Features

- ◆ Single 2.7V to 3.6V Supply Operation
- ◆ DC-Coupled Input/Output
- ◆ ± 1 dB Passband at 9MHz Reconstruction Filter with 50dB Attenuation at 27MHz
- ◆ Internal Preset 2V/V Gain
- ◆ Small 4-Bump UCSP™ Package
- ◆ Surface-Mount Components
- ◆ Fully Assembled and Tested

Ordering Information

PART	TYPE
MAX9515EVKIT+	EV Kit

+ Denotes lead-free and RoHS-compliant.

Component List

DESIGNATION	QTY	DESCRIPTION
C1	1	10 μ F $\pm 20\%$, 6.3V X5R ceramic capacitor (0805) TDK C2012X5R0J106M
C2	1	0.1 μ F $\pm 10\%$, 25V X7R ceramic capacitor (0603) TDK C1608X7R1E104K
GND	2	PC mini black test points
INPUT, OUTPUT	2	75 Ω BNC PCB-mount jack connectors
R1, R2	2	75 Ω $\pm 1\%$ resistors (0603)
TP1, TP2	2	PC mini red test points
U1	1	Video filter amplifier (4-bump UCSP, 1mm x 1mm) Maxim MAX9515ABS+ (Top Mark: AFN)
—	1	PCB: MAX9515 Evaluation Kit+

UCSP is a trademark of Maxim Integrated Products, Inc.



Maxim Integrated Products 1

For pricing, delivery, and ordering information, please contact Maxim Direct at 1-888-629-4642, or visit Maxim's website at www.maxim-ic.com.

MAX9515 Evaluation Kit

Quick Start

Required Equipment

Before beginning, the following equipment is needed:

- 2.7V to 3.6V, 500mA DC power supply (VDD)
- Video signal generator
- Video measurement equipment (e.g., Tektronix VM-700T)

Procedures

The MAX9515 EV kit is fully assembled and tested. Follow the steps below to verify board operation.

Caution: Do not turn on the power supply until all connections are completed.

- 1) Connect the power-supply ground to the GND pad on the EV kit.
- 2) Connect the power-supply positive terminal to the VDD pad on the EV kit.
- 3) Connect the video signal generator output to the INPUT BNC connector on the EV kit. The video signal must be approximately 0 to 1V. If the video signal is not between 0 and 1V, refer to the *How to Level Shift Video Signals for DC-Coupled Video Amplifiers/Filters* application note at www.maxim-ic.com/appnotes.cfm/an_pk/4028.
- 4) Connect the OUTPUT BNC connector on the EV kit to the input of the video measurement equipment.
- 5) Set the video signal generator for the desired video input signal. This signal must contain sync information.
- 6) Turn on the power supply and set to 3.3V.
- 7) Turn on the video signal generator and enable its output.
- 8) Analyze the video output signal with the video measurement equipment.

Detailed Description of Hardware

The MAX9515 evaluation kit (EV kit) is a fully assembled and tested surface-mount PCB that evaluates the MAX9515 video filter amplifier IC. The MAX9515 features intelligent power management by disabling the filter and output amplifier in the absence of a video input signal at the EV kit's input and/or an output video load at the EV kit's OUTPUT BNC connector. The EV kit operates from a single 2.7V to 3.6V power supply that provides up to 500mA.

The MAX9515 IC has an internal fixed 2V/V gain and an internal reconstruction filter that smoothes the steps and reduces the spikes on the video signal from the video digital-to-analog converter (DAC). The reconstruction filter has a ± 1 dB (typ) passband flatness to 9MHz and 50dB attenuation at 27MHz.

The MAX9515 EV kit accepts a full-scale video input signal of 1V_{P-P} (nominal) at INPUT and provides an output full-scale video signal of 2V_{P-P} (nominal) at the MAX9515 IC output. The EV kit input is terminated to ground by resistor R1 and the output is back terminated by resistor R2. The EV kit output expects to drive a DC-coupled load to ground. Test points TP1 and TP2 are provided for observing the IC input and output signals, respectively. The MAX9515 internal level shift circuit positions the sync tip at approximately 300mV at the TP2 output.

Automatic Shutdown

When an input video signal is present at INPUT and a load is connected at OUTPUT, the MAX9515 IC filter and amplifier turn on and remain on until the output load at OUTPUT is disconnected. The MAX9515 automatic shutdown reduces the EV kit supply current to < 9 μ A supply current based on the input signal presence and output loading.

Note: If a video signal is not present at the EV kit OUTPUT BNC connector, verify that a valid signal is present at test point TP1 and a valid 75 Ω load to ground is connected at OUTPUT. The MAX9515 IC does not go into full operation mode unless both of the above conditions are satisfied. When connecting OUTPUT directly to an oscilloscope, verify that the oscilloscope input is terminated with a 75 Ω load to ground.

MAX9515 Evaluation Kit

Evaluates: **MAX9515**

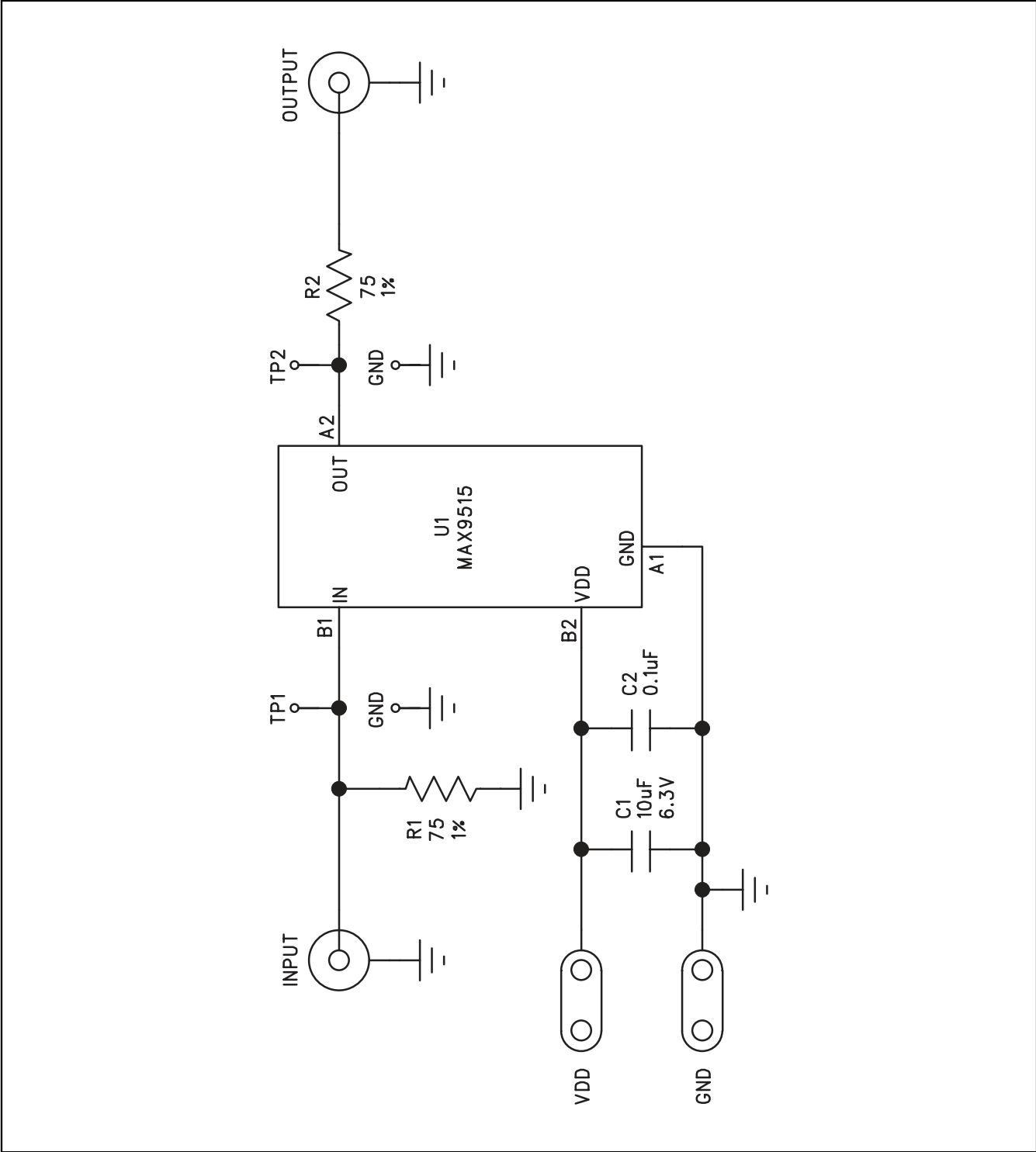

Figure 1. MAX9515 EV Kit Schematic

MAX9515 Evaluation Kit

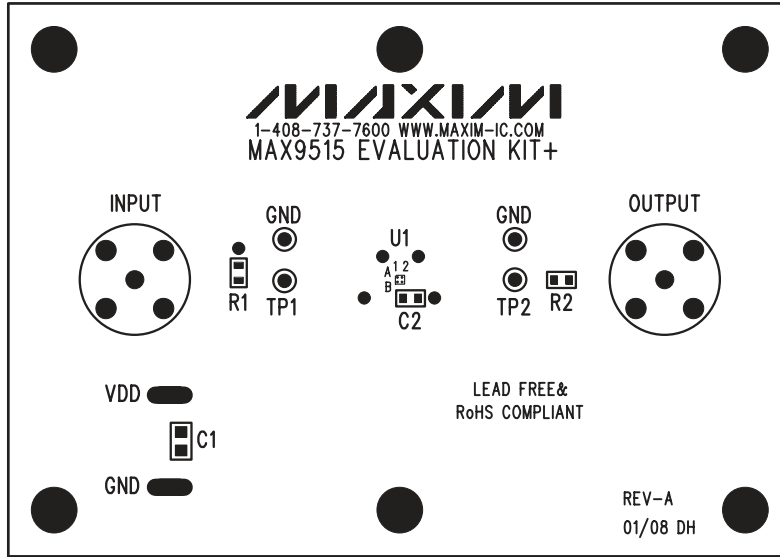

Figure 2. MAX9515 EV Kit Component Placement Guide—Component Side

MAX9515 Evaluation Kit

Evaluates: MAX9515

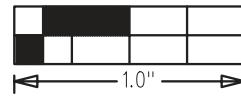
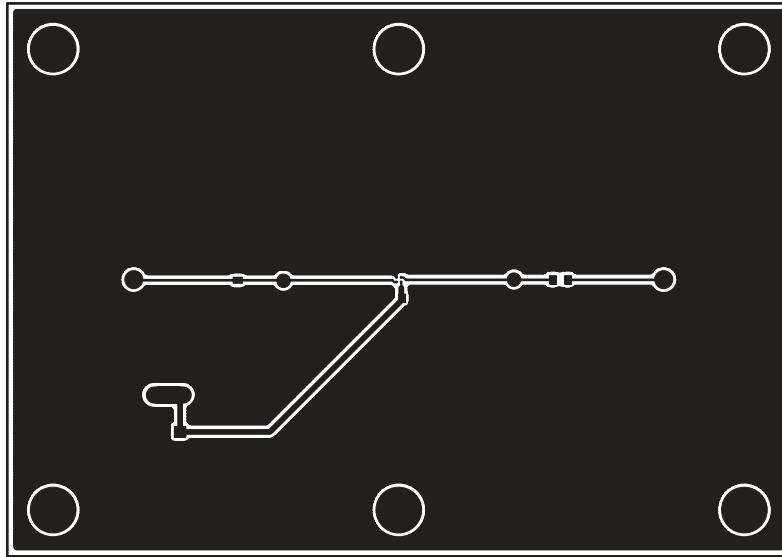

Figure 3. MAX9515 EV Kit PCB Layout—Component Side

MAX9515 Evaluation Kit

Evaluates: MAX9515

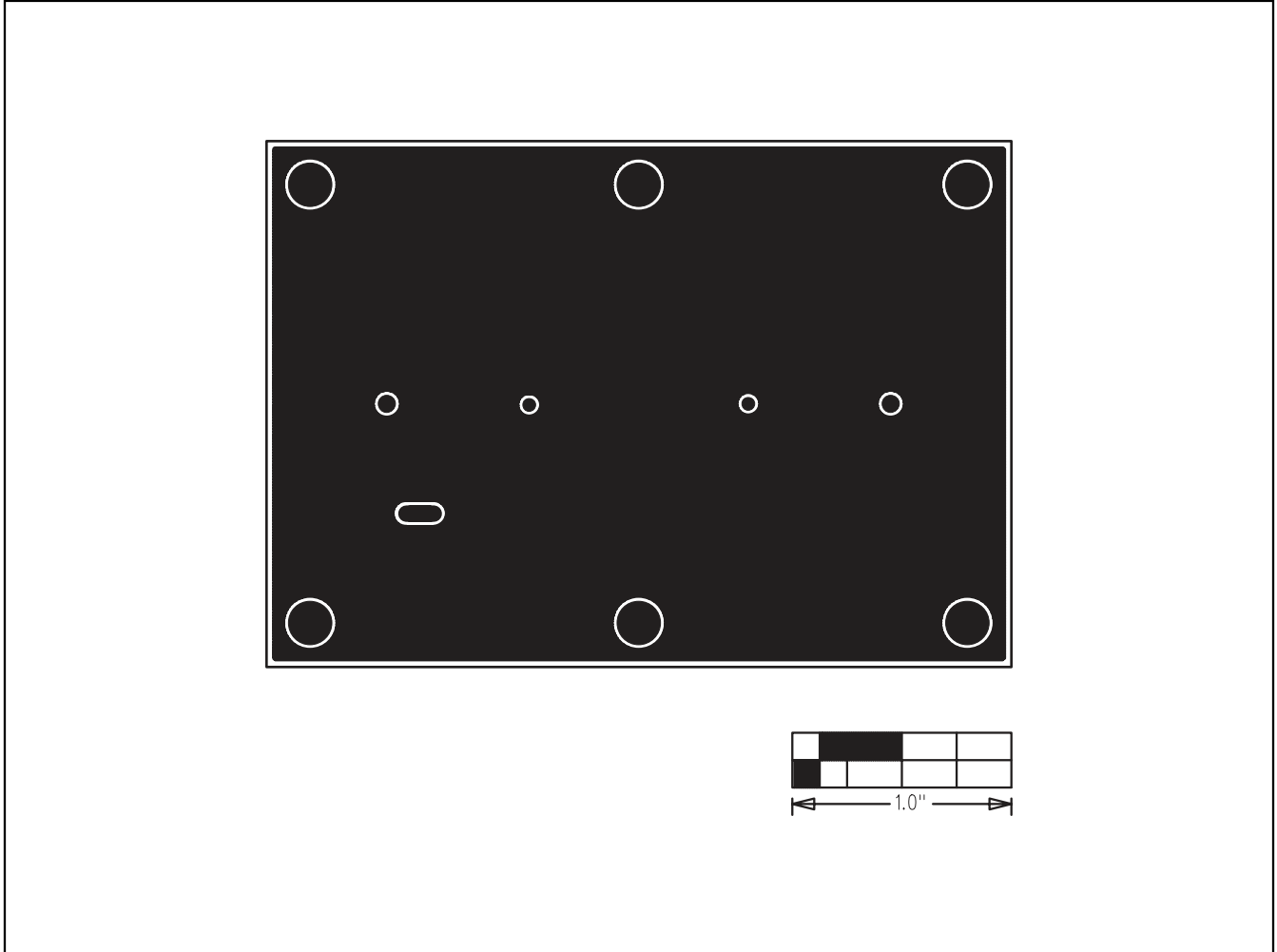

Figure 4. MAX9515 EV Kit PCB Layout—Solder Side

Maxim cannot assume responsibility for use of any circuitry other than circuitry entirely embodied in a Maxim product. No circuit patent licenses are implied. Maxim reserves the right to change the circuitry and specifications without notice at any time.

6 **Maxim Integrated Products, 120 San Gabriel Drive, Sunnyvale, CA 94086 408-737-7600**

© 2008 Maxim Integrated Products

MAXIM is a registered trademark of Maxim Integrated Products, Inc.