

TJ xx 11 x 3 xxxx G

- 02 2 CONTACTS
  - 03 3 CONTACTS
  - ... ..
  - 24 24 CONTACTS
- Color
- 0 Black (RAL9005)
  - 2 Red (RAL3001/D)
  - 3 Orange (RAL2011/P)
  - 4 Yellow (RAL1018/A)
  - 5 Green (RAL6018/T)
  - 6 Blue (RAL5015/A)
  - 8 Grey (RAL7035/D)
  - 9 White (RAL1102)
  - C Green (RAL6018/U)
- G RoHS compliant (lead<4%) In copper Alloy
- 0000 Standard @ Logo
  - 000A Standard ANY Logo
  - 0091 Standard ANY Logo
- Any special item by customer request, please contact sales department.

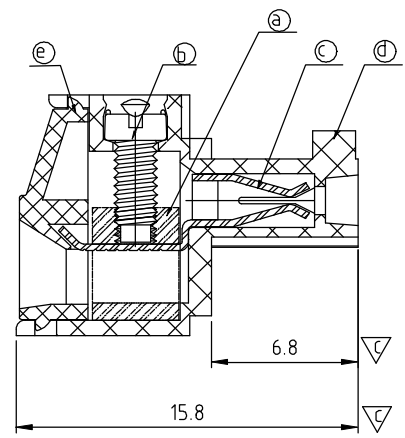

N = Number of poles  
 Dim A = N x 3.5  
 Dim B = (N-1) x 3.5

Poles	Dim A	Dim B
2p-6p	±0.15	±0.15
7p-12p	±0.20	±0.20
13p-18p	±0.25	±0.25
19p-24p	±0.30	±0.30

SIGN	DATE	DESCRIPTION	APPROVER
△	11/01'05	Electrical standard changed.	Marvin
△	04/20'06	2p to 6p with wedge is changed.	Marvin
△	8/13'06	Added VDE standard	梁仁松
△	10/30'06	Part No. is changed	Marvin
△	07/09'10	The solid and Stranded wire are changed from 16-26 to 16-28	Chen Bo
△	07/09'10	Remove the CSA mark	Chen Bo
△	08/12'13	update the drawing	Chen Bo

THIS IS CAD DRAWING, DO NOT REVISE MANUALLY!!!

Material

- Item a Clamp: Brass (CuZn) Ni plated
- Item b Terminal screw: Steel Zinc plating "-" slot type
- Item c Female contact: PhBz, Tin plated
- Item d Terminal (housing): PA66 (UL94V-0)
- Item e Terminal cover: PA66 (UL94V-0)

△ △ △

Electrical cULus/VDE

- Voltage rating: 300VAC/300VAC
- Current rating: 10A/10.5A
- Wire range: 1.5mm<sup>2</sup>
- Solid wire (AWG): 16-28
- Stranded wire (AWG): 16-28
- Torque: 3Lb-In/0.2Nm
- Screw: M2
- Wire strip length: 6-7mm
- Withstanding Voltage: 1.6KV/2.5KV
- Operating temperature: -40°C to +115°C
- Safety Approval:
- Critical dimension:

<b>ANYTEK</b>				<b>CUSTOMER COPY</b>			
TITLE		TJ-3.5mm Series 2p-24p		DWG NO.		8TJ0501	
PART NO.		TJxx11x3xxxxG		CUST NO.			
APPROVED		DESIGNED		DRAWN		Tolerance	
		Chen Bo 08/12'13		Chen Bo 08/12'13		X. ±0.50	
						X.X ±0.30	
						X.XX ±0.10	
						X° ±1°	
				SHEET: 01/01		UNIT: mm	
						SCALE: NONE	
						REV.: H	