

RV-8803-C7

Real-Time Clock Module with I²C-Bus

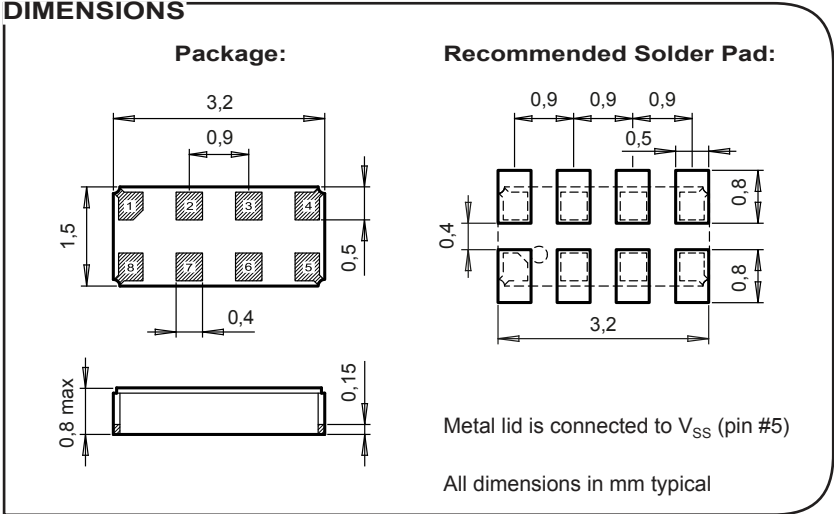

APPLICATIONS

- IoT
- Metering
- Industrial
- Automotive
- Health Care
- Wearables, Portables

DESCRIPTION

The RV-8803-C7 is a SMT Real-Time Clock Module that incorporates an integrated CMOS circuit together with an XTAL. It operates under vacuum in a hermetically sealed ceramic package with metal lid.

FEATURES

- Low power consumption: 240 nA @ 3 V.
- Wide operating voltage range: 1.5 V to 5.5 V.
- Time accuracy, temperature compensated: -40°C to +85°C, ±3 ppm.
- +85°C to +105°C, ±7 ppm.
- User programmable offset value.
- Provides year, month, date, weekday, hours, minutes, seconds and 100th seconds.
- Automatic leap year correction: 2000 to 2099.
- Timer, alarm and external event input with time stamp.
- Clock output frequencies: 32.768 kHz, 1024 Hz, 1 Hz.
- I²C-bus interface: 400 kHz.
- 100% Pb-free, RoHS-compliant.
- Automotive qualification according to AEC-Q200 available.

BLOCK DIAGRAM

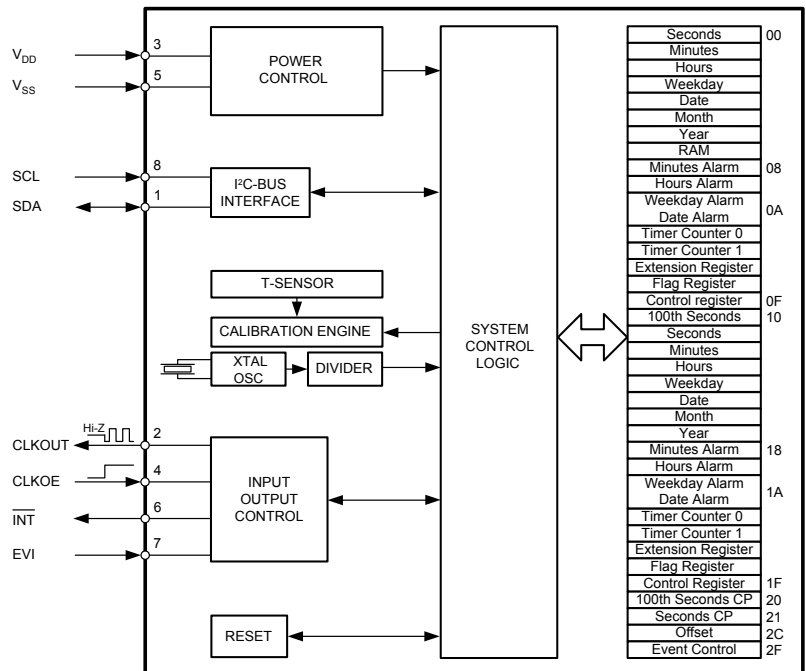

ELECTRICAL CHARACTERISTICS AT 25°C

More detailed information can be found in the Application Manual.

	Symbol	Condition	Min.	Typ.	Max	Unit
Supply voltage	V _{DD}	Temp. comp.	1.5		5.5	V
Current consumption Time keeping mode	I _{DDO}	I ² C-bus inactive, V _{DD} = 3 V		240	350	nA
Time accuracy	ΔF/F	-40 to +85°C	±3			ppm
		+85 to +105°C	±7			
Aging first year max.	ΔF/F	@ 25°C	±3			ppm

ENVIRONMENTAL CHARACTERISTICS

		Conditions	Max. Dev.
Storage temperature range		-55 to +125°C	
TA Operating temperature range		-40 to +85°C ¹⁾	
Shock resistance	ΔF/F	5000 g, 0.3 ms, ½ sine	±5 ppm
Vibration resistance	ΔF/F	20 g / 10–2000 Hz	±5 ppm

1) Supports extended range from +85°C to +105°C with limitations.

TERMINATIONS AND PROCESSING

Package	Termination	Processing
SON-8	Au flashed pads	IPC/JEDEC J-STD-020C 260°C / 20 - 40 s

FREQUENCY TEMPERATURE CHARACTERISTICS

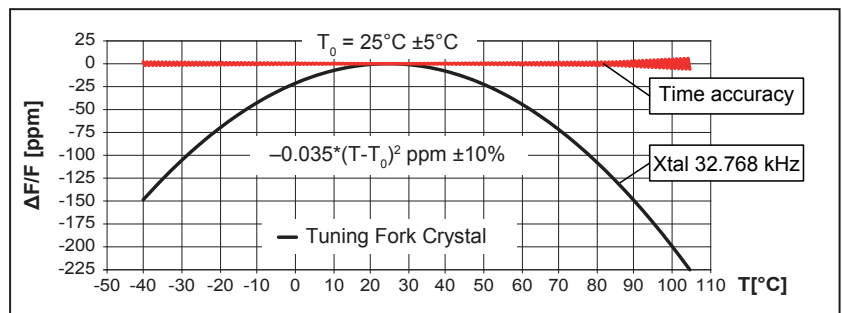

PIN CONNECTIONS TOP VIEW

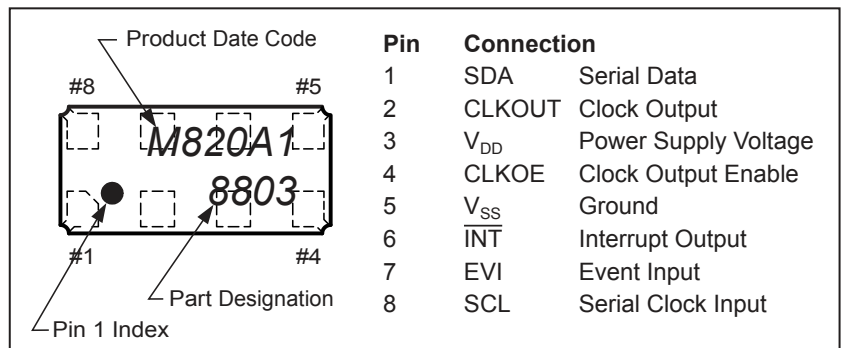

ORDERING INFORMATION

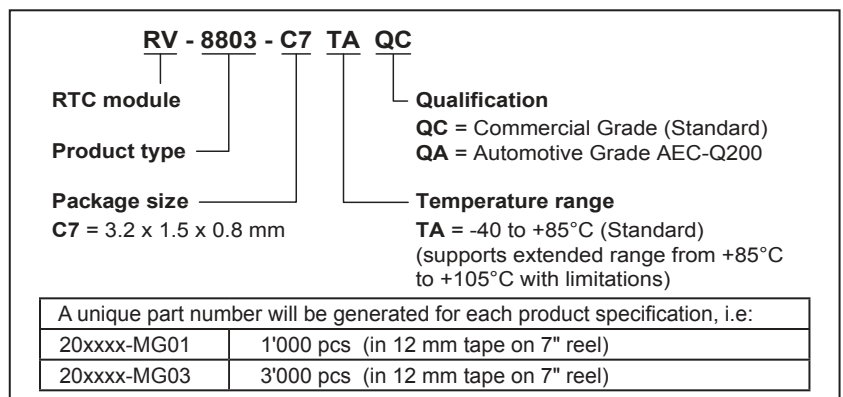

All specifications subject to change without notice.



A COMPANY OF THE SWATCH GROUP

Micro Crystal AG
Muehlestrasse 14
CH-2540 Grenchen
Switzerland

Phone +41 32 655 82 82
Fax +41 32 655 82 83
sales@microcrystal.com
www.microcrystal.com