

REVISIONS			
REV	DESCRIPTION, ECN, EAR NO.	DATE	APP'D
A	PROPOSAL PER EAR# RJ19114	SEP18/19	L.CHAN

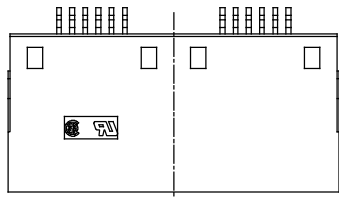

TOP VIEW

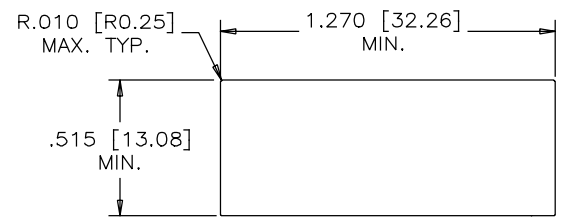

RECOMMENDED PANEL CUTOUT

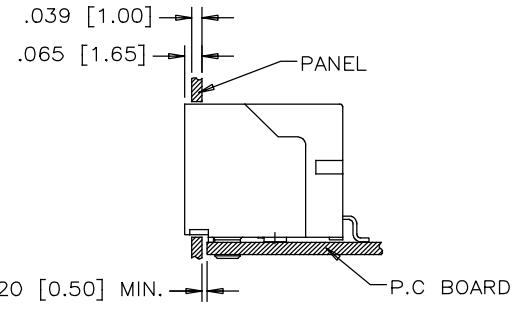

RECOMMENDED PANEL CUTOUT

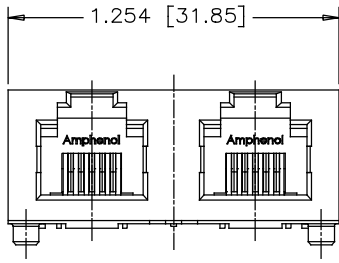

FRONT VIEW

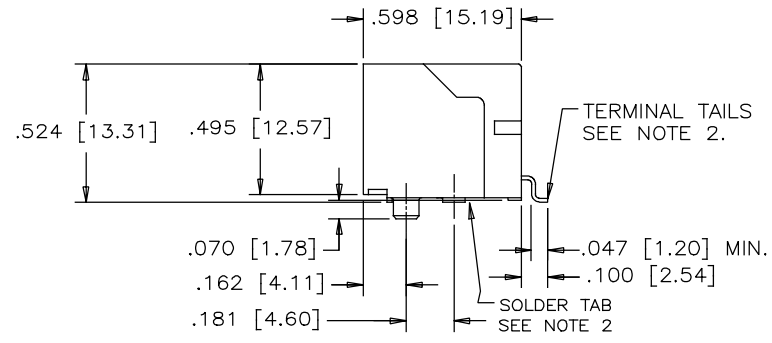

SIDE VIEW

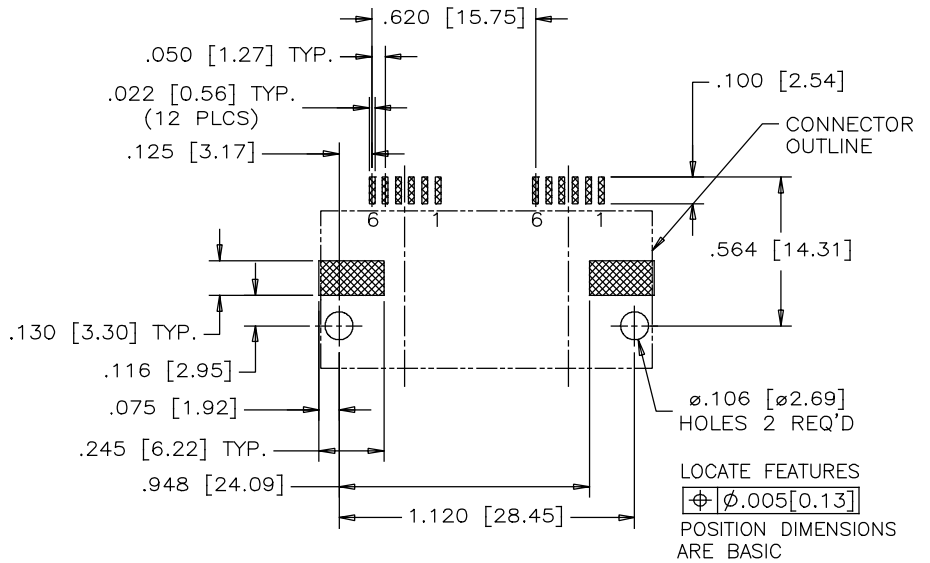

RECOMMENDED P.C.B. LAYOUT
(COMPONENT SIDE OF BOARD)
TOLERANCE: ±0.05 [.002]

NOTES:

1. MATERIAL:

- HOUSING: HIGH TEMPERATURE THERMOPLASTIC
FLAMMABILITY RATING UL 94V-0
COLOR:BLACK
- CONTACTS: PHOSPHOR BRONZE
PLATING: 20 μ" [0.508 MICRONS]
MIN. GOLD ON MATING SURFACES.
50 μ" [1.27 MICRONS]
MIN. NICKEL UNDERPLATE
100 μ" [2.54 MICRONS]
MIN. MATTE TIN OR GOLD FLASH
ON CONTACT TAILS.
- SOLDER TAB: COPPER ALLOY WITH TIN FINISHED.

2. COPLANARITY SPECIFICATION:

WITH THE MODULAR JACK SITTING ON A LEVEL SURFACE, THE MAXIMUM GAP BETWEEN THE LEVEL SURFACE AND ALL TERMINAL TAILS AND BOTH FITTING NAILS IS .004 [0.10].

AMPHENOL PART NUMBER: RJSSE-7060-02T



UNLESS SPECIFIED OTHERWISE	DRAWN RONNIE.C	SEP18/19
PRIMARY UNITS INCHES	CHECKED KELVIN.T	SEP18/19
SECONDARY MILLIMETERS	M.E. APP'D	
REFERENCE IN PARENTHESES	Q.A. APP'D	
GENERAL TOLERANCES	DWG APP'D	
1 DECIMAL PLACE	ENG. REL NO. EAR# RJ19114	
2 DECIMAL PLACES	REF.	
3 DECIMAL PLACES ±.015		
ANGULAR DEGREES ±1.5°		

Amphenol Canada Corp. Commercial Products	
2 PORTS SURFACE MOUNT JACK, UNSHIELDED, WITH HOLD DOWN BRACKET, 6 POSITION, 6 CONTACTS, T&R PACKAGING, -ROHS COMPLIANT	
DWG NO. P-RJSSE-7060-02T	REV A
CODE ID NO. 03554	DWG SIZE X SCALE 1:1 SHEET 1 OF 2

REVISIONS			
REV	DESCRIPTION, ECN, EAR NO.	DATE	APP'D
A	PROPOSAL PER EAR# RJ19114	SEP18/19	L.CHAN

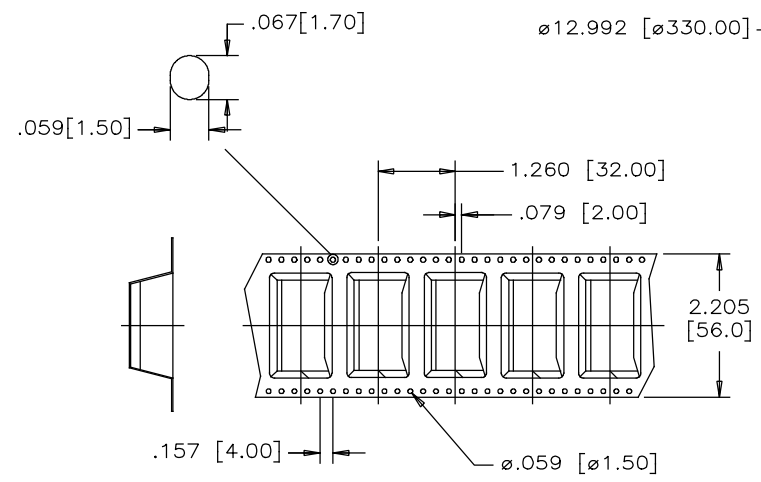
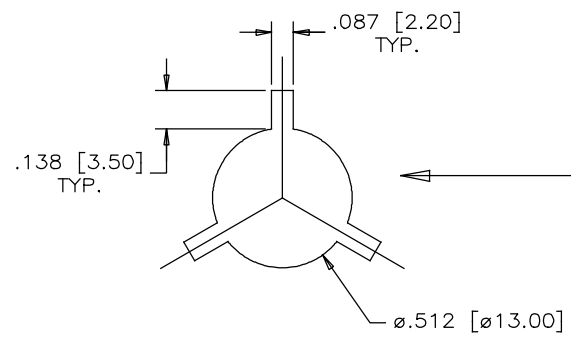
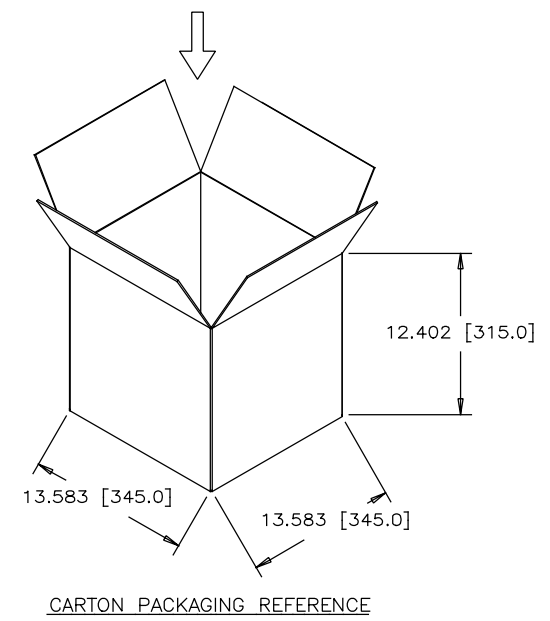
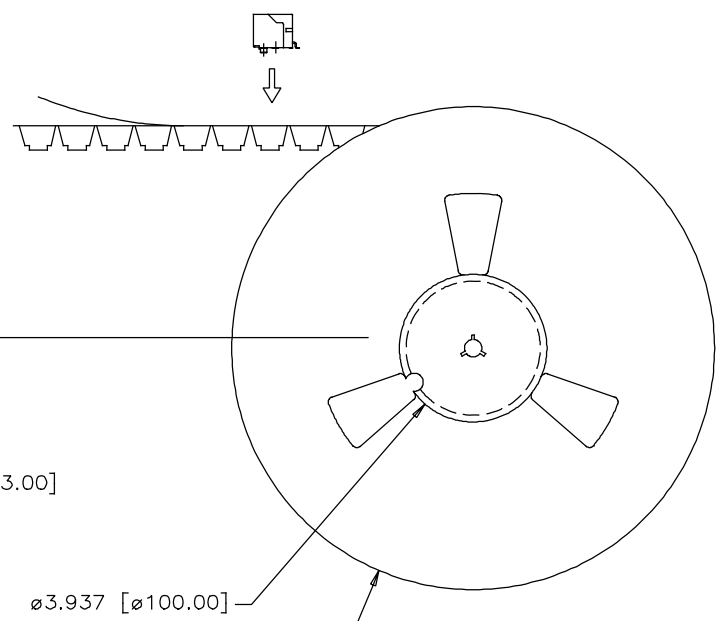
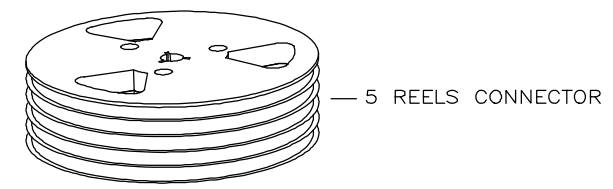
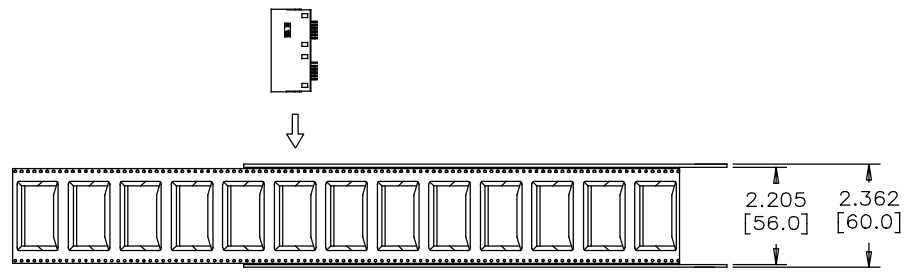

PACKAGING NOTES:

- ONE REEL SHOULD HOLD 100 CONNECTORS.
- A FULLY LOADED CARTON SHOULD CONTAIN 5 REELS (500 PCS) OF CONNECTOR.

UNLESS SPECIFIED OTHERWISE	DRAWN RONNIE.C	SEP18/19	Amphenol Canada Corp. Commercial Products
PRIMARY UNITS INCHES	CHECKED KELVIN.T	SEP18/19	
SECONDARY MILLIMETERS	M.E. APP'D		2 PORTS SURFACE MOUNT JACK, UNSHIELDED, WITH HOLD DOWN BRACKET, 6 POSITION, 6 CONTACTS, T&R PACKAGING, -RoHS COMPLIANT
REFERENCE IN PARENTHESES	Q.A. APP'D		
GENERAL TOLERANCES	DWG APP'D		DWG NO. P-RJSSE-7060-02T
1 DECIMAL PLACE	ENG. REL NO. EAR# RJ19114		
2 DECIMAL PLACES	REF.		REV A
3 DECIMAL PLACES ±.015	THIRD ANGLE PROJECTION	DO NOT SCALE DRAWING	CODE ID NO. 03554 DWG SIZE X SCALE N/A SHEET 2 OF 2
ANGULAR DEGREES ±1.5°			

THIS DOCUMENT CONTAINS PROPRIETARY INFORMATION AND SUCH INFORMATION MAY NOT BE DISCLOSED TO OTHERS FOR ANY PURPOSE OR USED FOR MANUFACTURING PURPOSES WITHOUT WRITTEN PERMISSION FROM AMPHENOL CANADA CORP.