

THIS DRAWING IS UNPUBLISHED. RELEASED FOR PUBLICATION
 © COPYRIGHT - By - ALL RIGHTS RESERVED.

| LOC | | DIST | | REVISIONS | | | |
|-----|-----|-------------|---------------------------|-----------|------|-----|--|
| P | LTR | DESCRIPTION | DATE | DWN | APVD | | |
| GP | 00 | A1 | REVISED PER ECO-11-004835 | 11MAR11 | RK | HMR | |

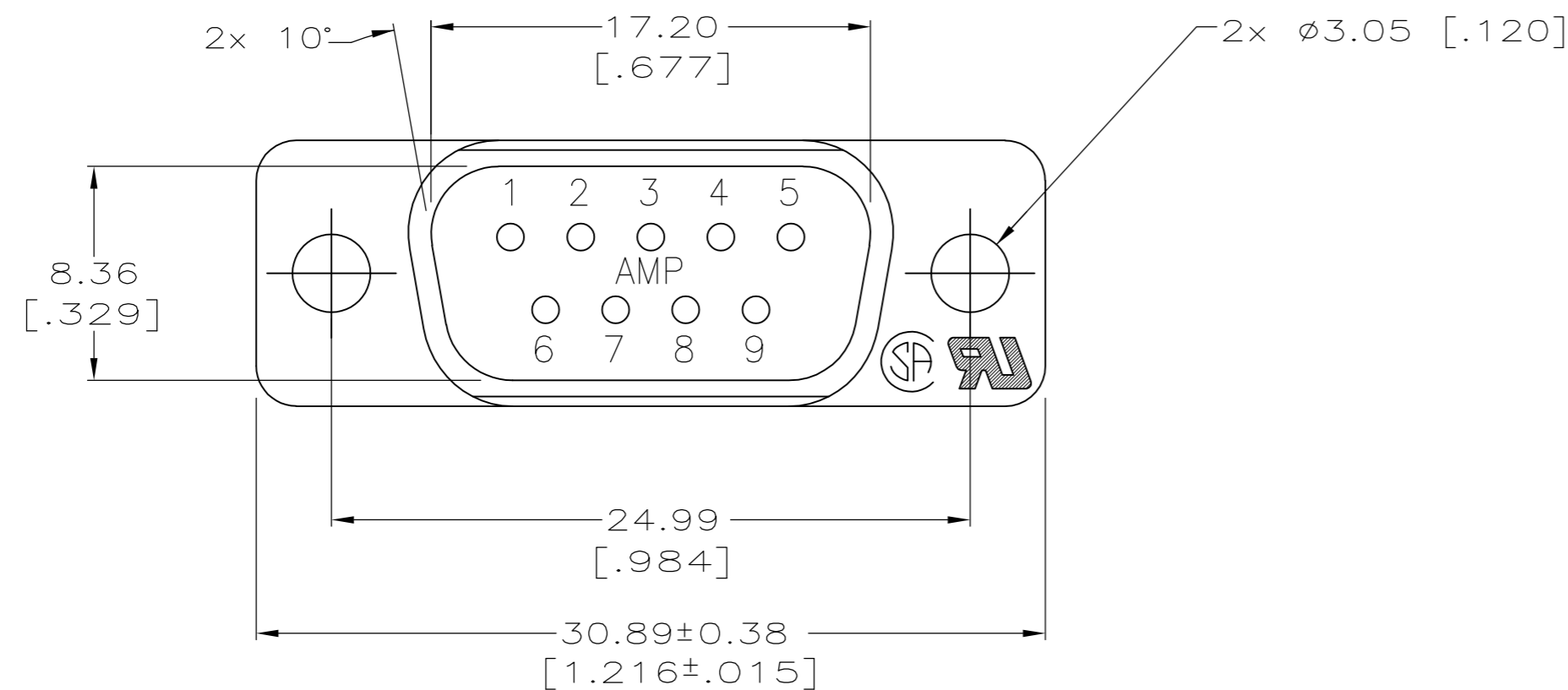

- 1 HOUSING: BLACK POLYESTER, UL 94V-0 RATED.
CONTACTS: BRASS.
- 2 GOLD PLATED FOR LENGTH OF 3.81[.150] MIN FROM MATING END, GOLD FLASH IN MATED AREA, 2.54µm [.000100] MIN TIN ON SOLDER END, BOTH OVER 1.27µm [.000050] MIN NICKEL.
- 3 GOLD PLATED FOR LENGTH OF 3.81[.150] MIN FROM MATING END, 0.76µm [.000030] MIN GOLD IN MATED AREA, 2.54µm [.000100] MIN TIN ON SOLDER END, BOTH OVER 1.27µm [.000050] MIN NICKEL.
OR
GOLD FLASH OVER PALLADIUM NICKEL PLATED FOR LENGTH OF 3.81 [.150] MIN FROM MATING END, 0.76µm [.000030] MIN PALLADIUM NICKEL IN MATED AREA, 2.54µm [.000100] MIN TIN ON SOLDER END, BOTH OVER 1.27µm [.000050] MIN NICKEL.

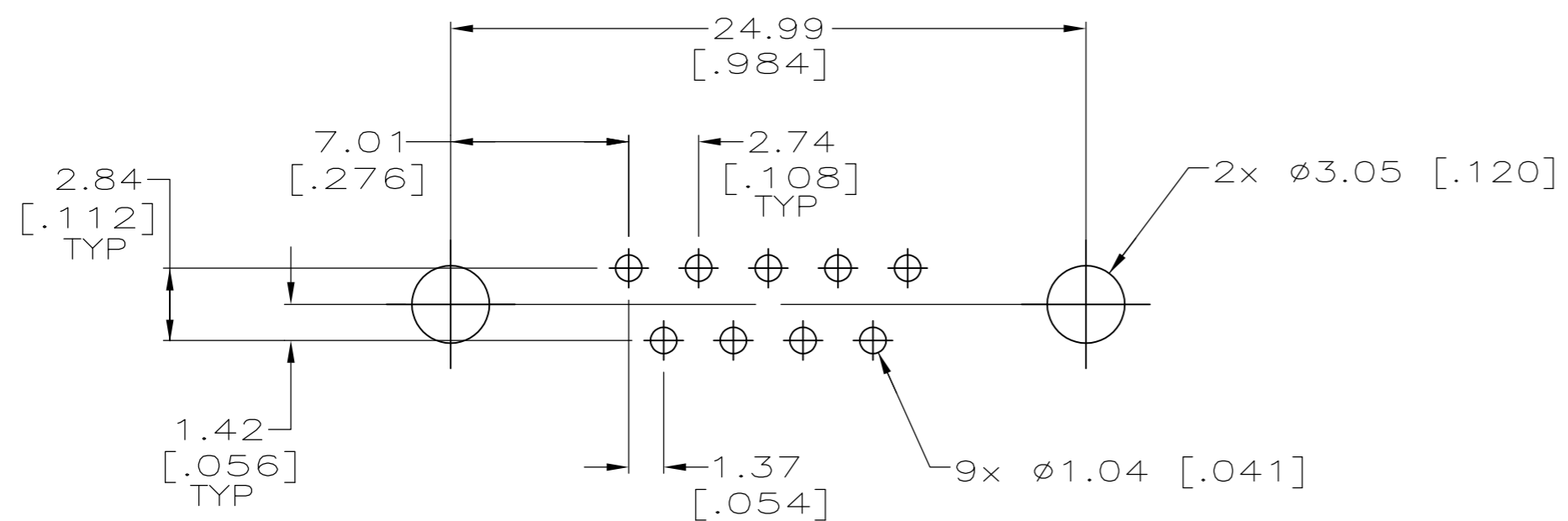
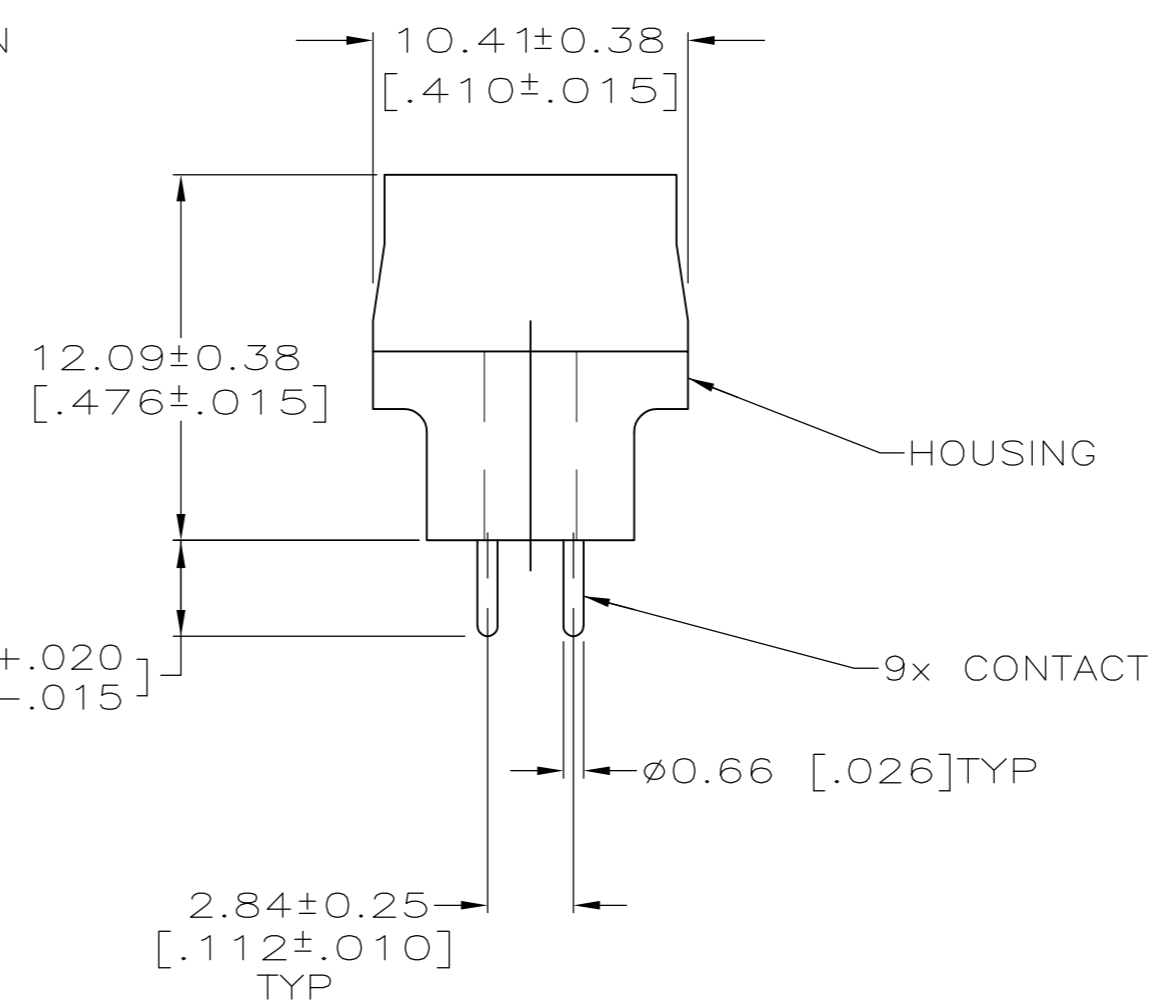
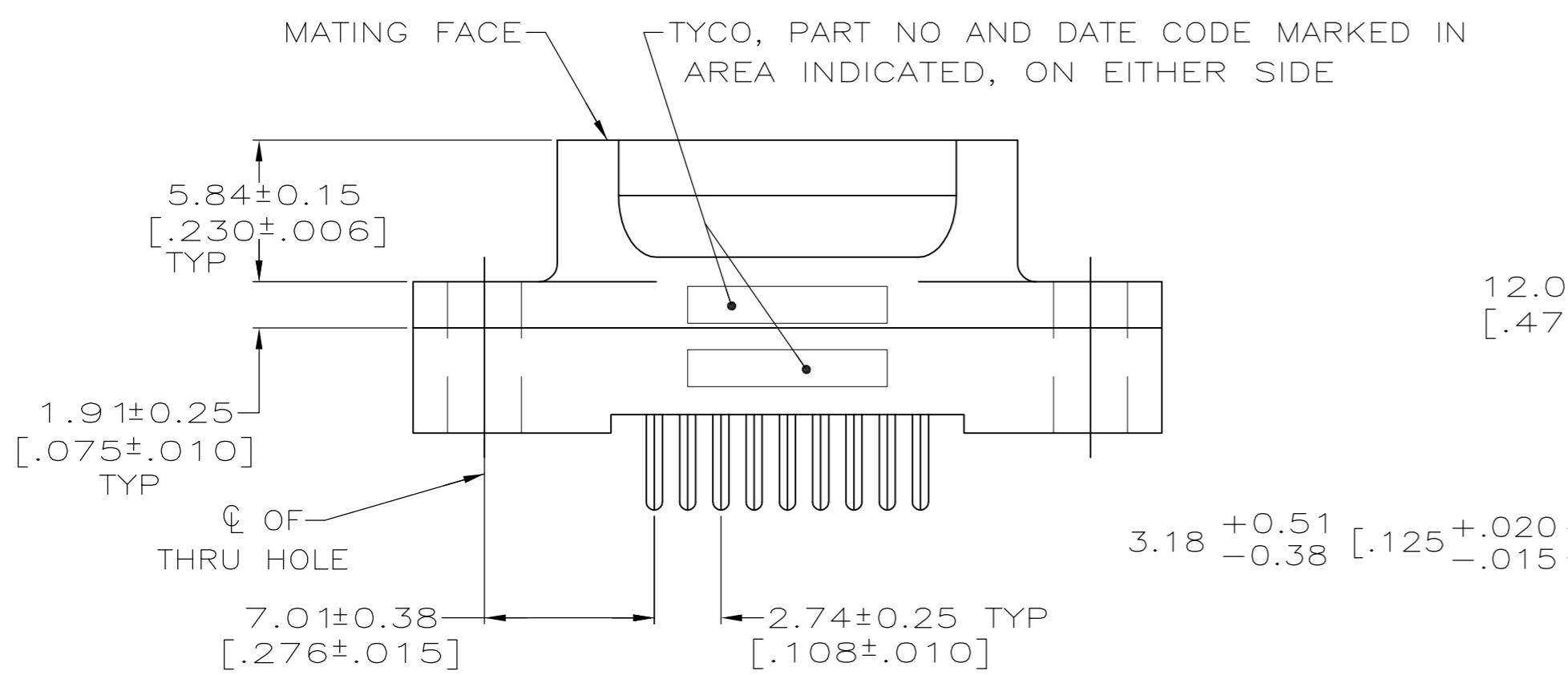

RECOMMENDED PC BOARD MOUNTING DIMENSIONS

| | |
|----------------|-----------|
| 3 | 5208006-2 |
| 2 | 5208006-1 |
| CONTACT FINISH | PART NO |

| | | | | | | | | | |
|--|--|------------------|------------|---------|---------------------|------------------|-----------|--|---------------|
| THIS DRAWING IS A CONTROLLED DOCUMENT. | | DWN | G.PETERS | 12SEP05 | TE Connectivity | NAME | | PLUG ASSEMBLY, SIZE 1, 9 POSN, VERTICAL, AMPLIMITE HD-20 | |
| DIMENSIONS: mm [INCHES] | | CHK | S.BOLASH | 12SEP05 | | PRODUCT SPEC | | 108-40025 | |
| TOLERANCES UNLESS OTHERWISE SPECIFIED: | | APVD | M.WALMSLEY | 12SEP05 | | APPLICATION SPEC | | - | |
| 0 PLC ± - | | MATERIAL | | WEIGHT | | - | SIZE | A2 | CAGE CODE |
| 1 PLC ± - | | FINISH | | 1 2 3 | | DRAWING NO | C=5208006 | | RESTRICTED TO |
| 2 PLC ± 0.13 [.005] | | CUSTOMER DRAWING | | SCALE | | 4:1 | | SHEET | 1 of 1 |
| 3 PLC ± - | | | | | | | | REV | A1 |
| 4 PLC ± - | | | | | | | | | |
| ANGLES ± 2° | | | | | | | | | |