

NOTES:

- 1) MATERIAL:
HOUSING: NYLON(IPA), GLASS FILLED, UL94V-0, COLOR: SEE CHART
TERMINALS: PHOSPHOR BRONZE
- 2) FINISH:
TERMINALS:
SELECT GOLD IN CONTACT AREA: 50 MICROINCHES (1.27 MICROMETERS) MIN.
SELECT TIN IN PC TAIL AREA: 100 MICROINCHES (2.54 MICROMETERS) MIN.,
WITH OVERALL NICKEL UNDERPLATE: 50 MICROINCHES (1.27 MICROMETERS) MIN.
- 3) PRODUCT SPECIFICATION: PS-43860-003.
- 4) PACKAGING SPECIFICATION:
CONNECTOR ASSEMBLIES PACKAGED IN EXTRUDED TUBES PER MOLEX
PACKAGING SPECIFICATION PK-43860-004.
- 5) ALL UNTOLERANCED DIMENSIONS ARE SHOWN FOR REFERENCE ONLY.
- 6) CONFORMS TO FCC REGULATION PART 68.5 FOR MODULAR JACKS.
- 7) THIS PART CONFORMS TO CLASS B REQUIREMENTS OF COSMETIC
SPECIFICATION PS-45499-002.

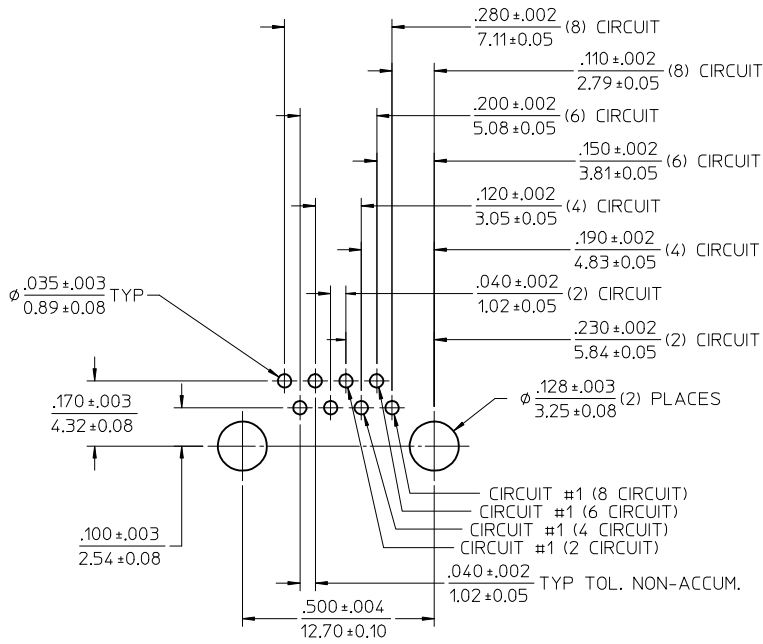

PC BOARD LAYOUT
COMPONENT SIDE OF BOARD
RECOMMENDED PCB THICKNESS .062±.005/1.57±0.13

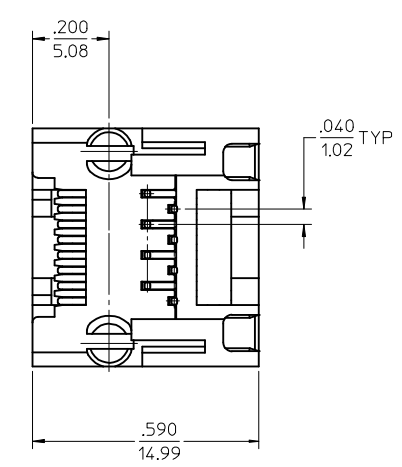
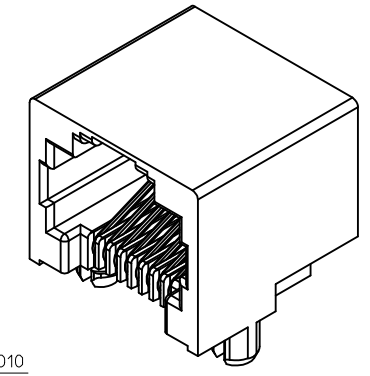
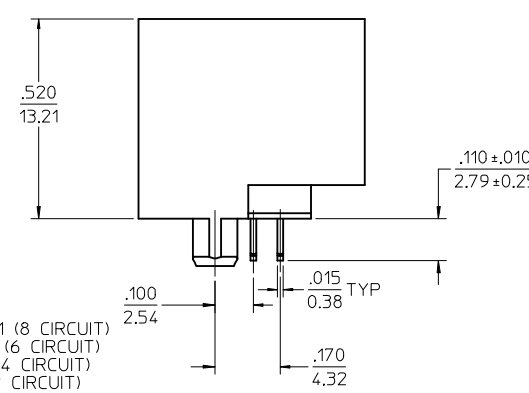
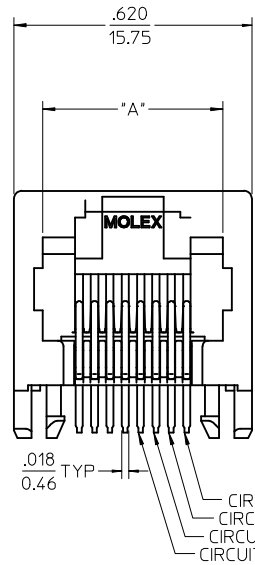

ASSEMBLY MAT. NUM.	CONNECTOR SIZE	DIM "A"	CIRCUITS	HOUSING COLOR
43860-0001	8	.469/11.91	8	BLACK
43860-0002	6	.389/9.88	6	BLACK
43860-0003	6	.389/9.88	4	BLACK
43860-0020	6	.389/9.88	2	BLACK

OBSOLETE PN IEC NO: UCP2017-0469 DRWN:AFENG02 2016/08/30 CHKD: APPR:KLANG 2016/08/31	DESCRIPTION REV:	QUALITY SYMBOLS ▽=0 ▽=0 ▽=0	GENERAL TOLERANCES (UNLESS SPECIFIED) mm INCH 4 PLACES ± --- ± --- 3 PLACES ± --- ± .010 2 PLACES ± 0.25 ± --- 1 PLACE ± --- ± --- 0 PLACE ± ±	DIMENSION STYLE IN/MM	SCALE 4:1	DESIGN UNITS INCH	THIRD ANGLE PROJECTION
		DRAWN BY TALEND	DATE 1997/02/13	TITLE INVERTED MODULAR JACK ASSEMBLY			
		CHECKED BY ROBERTS	DATE 1997/03/03	APPROVED BY FRY			
		DATE 1997/03/04	MATERIAL NO. SEE CHART				
DRAFT WHERE APPLICABLE MUST REMAIN WITHIN DIMENSIONS			ANGULAR ±1/2°		DOCUMENT NO. SD-43860-001	SHEET NO. 1 OF 5	
THIS DRAWING CONTAINS INFORMATION THAT IS PROPRIETARY TO MOLEX INCORPORATED AND SHOULD NOT BE USED WITHOUT WRITTEN PERMISSION							

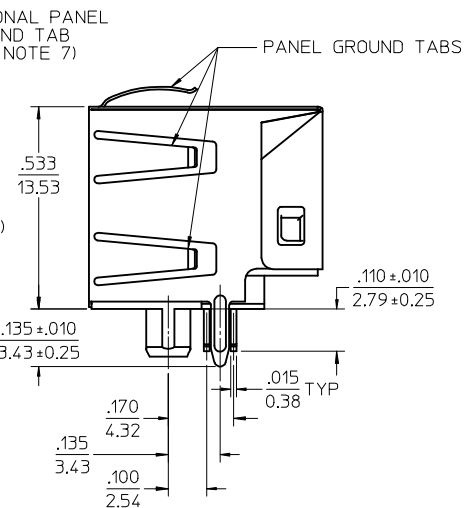
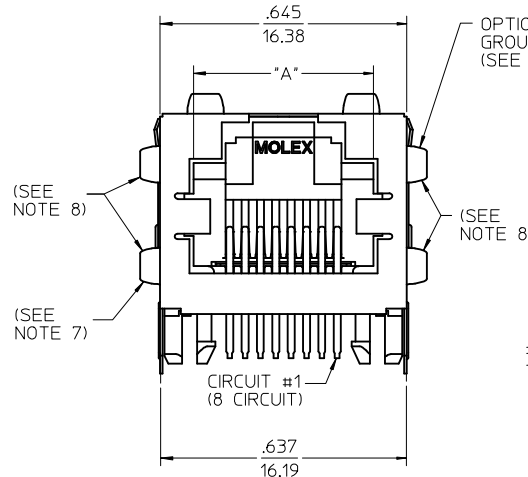
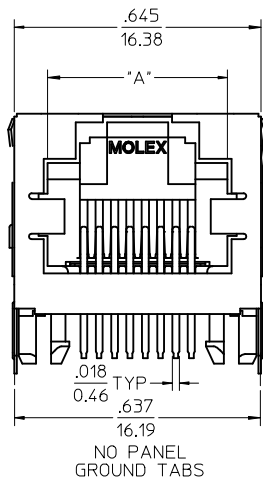
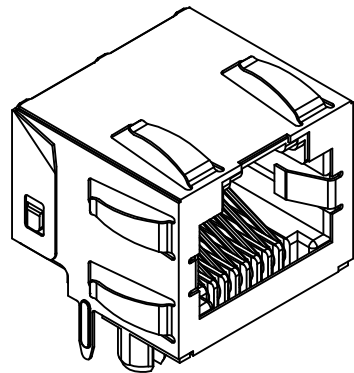

NOTES:

- 1) MATERIAL:
HOUSING: NYLON(PA), GLASS FILLED, UL94V-0,
COLOR: BLACK
TERMINALS: PHOSPHOR BRONZE
SHIELD: BRASS
- 2) FINISH:
TERMINALS:
SELECT GOLD IN CONTACT AREA: 50 MICROINCHES/
1.27 MICROMETERS MIN.,
SELECT TIN IN PC TAIL AREA: 100 MICROINCHES/
2.54 MICROMETERS MIN.,
WITH OVERALL NICKEL UNDERPLATE: 50 MICROINCHES/
1.27 MICROMETERS MIN.
SHIELD:
100 MICROINCHES/2.54 MICROMETERS NICKEL OVER
50 MICROINCHES/1.27 MICROMETERS COPPER
UNDERPLATE, PCB GROUND TABS DIPPED IN TIN
- 3) PRODUCT SPECIFICATION: PS-43860-003.
- 4) PACKAGING SPECIFICATION:
CONNECTOR ASSEMBLIES PACKAGED IN THERMOFORMED TRAYS
PER MOLEX PACKAGING SPECIFICATION PK-43860-005.
43860-5025 CONNECTOR ASSEMBLIES PACKAGED IN TAPE AND
REEL PER MOLEX PACKAGING SPECIFICATION PK-70873-700*
- 5) ALL UNTOLERANCED DIMENSIONS ARE SHOWN FOR REFERENCE ONLY.
- 6) CONFORMS TO FCC REGULATION PART 68.5 FOR MODULAR JACKS.
- 7) AVAILABLE WITH THE (2) SPECIFIED PANEL GROUND TABS
OMITTED FOR SIDE TO SIDE STACKABILITY, PER THE ASSEMBLY
MATERIAL NUMBER TABLE.
- 8) AVAILABLE WITH TOP PANEL GROUND TABS ONLY, PER THE
ASSEMBLY MATERIAL NUMBER TABLE.
- 9) THIS PART CONFORMS TO CLASS B REQUIREMENTS OF COSMETIC
SPECIFICATION PS-45499-002.

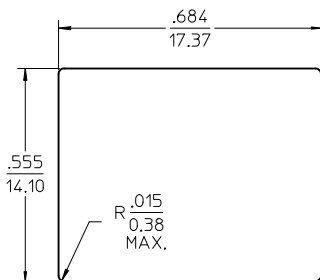

RECOMMENDED
PANEL
OPENING

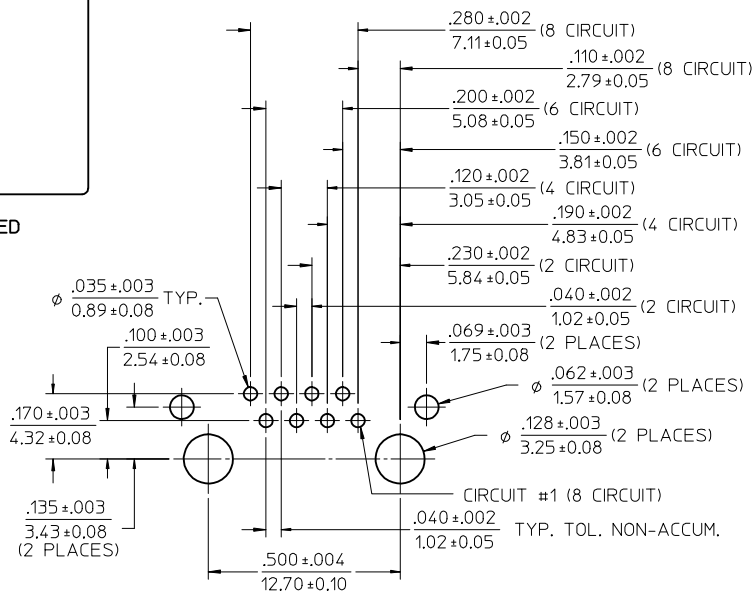

PC BOARD LAYOUT
COMPONENT SIDE OF BOARD
RECOMMENDED PCB THICKNESS .062±.005/1.57±.013

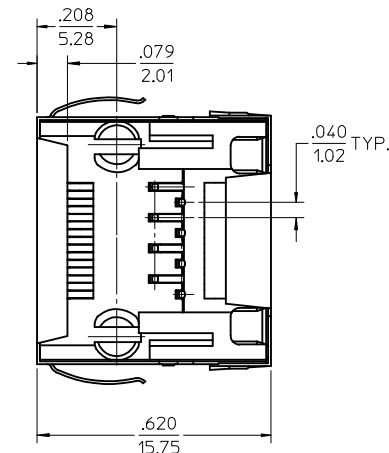

ASSEMBLY MAT. NUM.	CONNECTOR SIZE	DIM "A"	CIRCUITS	PANEL GROUND TABS	PACKAGING OPTION
43860-0004	8	.469/11.91	8	ALL	TRAY
43860-0005	6	.389/9.88	6	ALL	TRAY
43860-0006	6	.389/9.88	4	ALL	TRAY
43860-0013	8	.469/11.91	8	SEE NOTE #7	TRAY
43860-0014	6	.389/9.88	6	SEE NOTE #7	TRAY
43860-0025	8	.469/11.91	8	NONE	TRAY
43860-0026	6	.389/9.88	6	NONE	TRAY
43860-0027	6	.389/9.88	4	NONE	TRAY
43860-0031	8	.469/11.91	8	SEE NOTE #8	TRAY
43860-5025	8	.469/11.91	8	NONE	TAPE

SEE SHEET 1 EC NO: UCP2017-0469 DRW:WAFENG02 2016/08/30 CHKD: APPR:KLANG 2016/08/31 REV: H10	QUALITY SYMBOLS	GENERAL TOLERANCES (UNLESS SPECIFIED)	DIMENSION STYLE IN/MM	SCALE 4:1	DESIGN UNITS INCH	THIRD ANGLE PROJECTION
	▽=0	mm INCH	DRAWN BY TALEND	DATE 1997/02/13	TITLE INVERTED MODULAR JACK ASSEMBLY	
	▽=0	4 PLACES ± --- ± ---	CHECKED BY ROBERTS	DATE 1997/03/03		
	▽=0	3 PLACES ± --- ±.010	APPROVED BY FRY	DATE 1997/03/04		
ANGULAR ±1/2°		MATERIAL NO. SEE CHART		DOCUMENT NO. SD-43860-001		SHEET NO. 2 OF 5
DRAFT WHERE APPLICABLE MUST REMAIN WITHIN DIMENSIONS THIS DRAWING CONTAINS INFORMATION THAT IS PROPRIETARY TO MOLEX INCORPORATED AND SHOULD NOT BE USED WITHOUT WRITTEN PERMISSION						

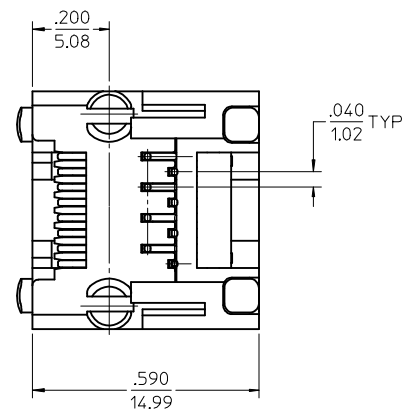
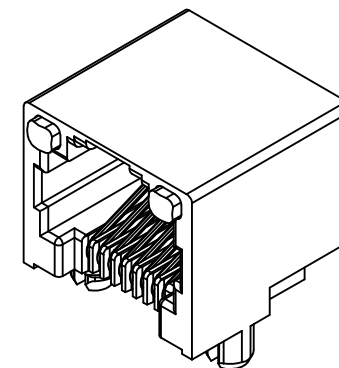
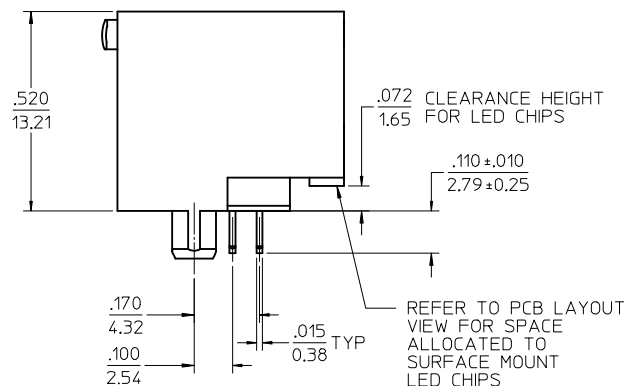
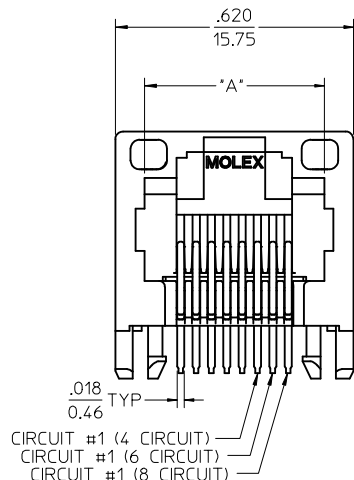

- NOTES:
- MATERIAL:
 HOUSING: NYLON(PA), GLASS FILLED, UL94V-0, COLOR: BLACK
 TERMINALS: PHOSPHOR BRONZE
 LIGHT PIPES:
 POLYCARBONATE - WAVE OR HAND SOLDER ONLY
 (NOT DESIGNED FOR I/R REFLOW OR CONVECTION REFLOW SOLDER PROCESSES)
 POLYSULFONE - MAXIMUM REFLOW TEMPERATURE 400°F (205°C)
 - FINISH:
 TERMINALS:
 SELECT GOLD IN CONTACT AREA: 50 MICROINCHES (1.27 MICROMETERS) MIN.,
 SELECT TIN IN PC TAIL AREA: 100 MICROINCHES (2.54 MICROMETERS) MIN.,
 WITH OVERALL NICKEL UNDERPLATE: 50 MICROINCHES (1.27 MICROMETERS) MIN.
 - PRODUCT SPECIFICATION AND PROCESSING PARAMETERS: PS-43860-003.
 - PACKAGING SPECIFICATION:
 CONNECTOR ASSEMBLIES PACKAGED IN EXTRUDED TUBES PER MOLEX PACKAGING SPECIFICATION PK-43860-004.
 - APPLICATION SPECIFICATION: AS-43860-001
 - ALL UNTOLERANCED DIMENSIONS ARE SHOWN FOR REFERENCE ONLY.
 - CONFORMS TO FCC REGULATION PART 68.5 FOR MODULAR JACKS.
 - REFER TO SHEET (5) OF (5) FOR RECOMMENDED PCB LAYOUT.
 - THIS PART CONFORMS TO CLASS B REQUIREMENTS OF COSMETIC SPECIFICATION PS-45499-002.

ASSEMBLY MAT. NUM.	LIGHT PIPE MATERIAL	CONNECTOR SIZE	DIM "A"	CIRCUITS
43860-0007	POLYCARBONATE	8	.469/11.91	8
43860-0008	POLYCARBONATE	6	.389/9.88	6

SEE SHEET 1 DEC NO: UCP2017-0469 DRAWN: AFENG02 2016/08/30 CHKD: APPR: KLANG 2016/08/31	QUALITY SYMBOLS	GENERAL TOLERANCES (UNLESS SPECIFIED)	DIMENSION STYLE IN/MM	SCALE 4:1	DESIGN UNITS INCH	THIRD ANGLE PROJECTION
	▽=0	4 PLACES ± --- ± ---	mm INCH	DRAWN BY TALEND	DATE 1997/02/13	TITLE INVERTED MODULAR JACK ASSEMBLY
	▽=0	3 PLACES ± --- ± .010		CHECKED BY ROBERTS	DATE 1997/03/03	
	▽=0	2 PLACES ± 0.25 ± ---		APPROVED BY FRY	DATE 1997/03/04	
		1 PLACE ± --- ± ---				
		0 PLACE ± ±				
		ANGULAR ±1/2°		MATERIAL NO.	DOCUMENT NO.	SHEET NO.
		DRAFT WHERE APPLICABLE MUST REMAIN WITHIN DIMENSIONS		SEE CHART	SD-43860-001	3 OF 5
			SIZE C	THIS DRAWING CONTAINS INFORMATION THAT IS PROPRIETARY TO MOLEX INCORPORATED AND SHOULD NOT BE USED WITHOUT WRITTEN PERMISSION		

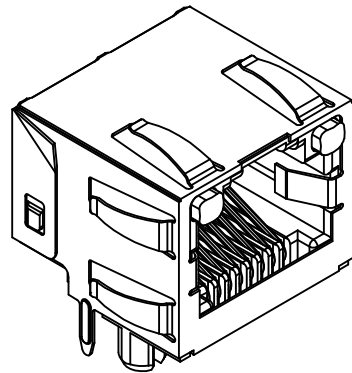

OPTIONAL PANEL GROUND TAB (SEE NOTE 8)

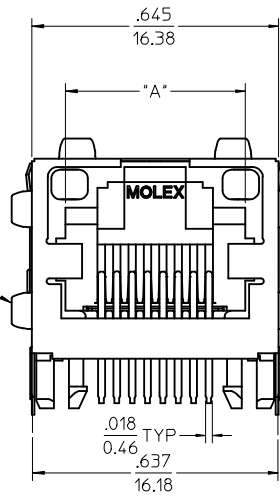

OPTIONAL PANEL GROUND TAB (SEE NOTE 8)

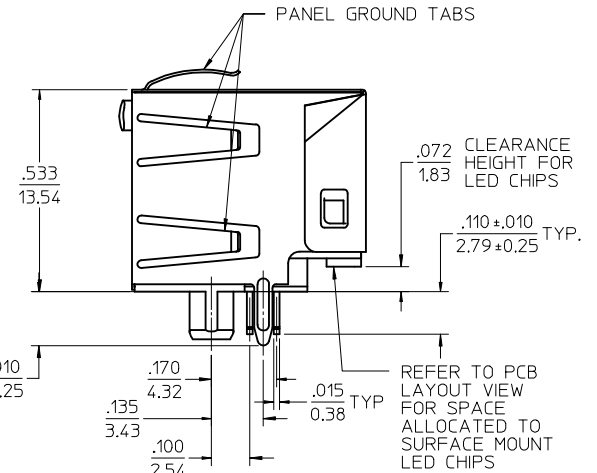

REFER TO PCB LAYOUT VIEW FOR SPACE ALLOCATED TO SURFACE MOUNT LED CHIPS

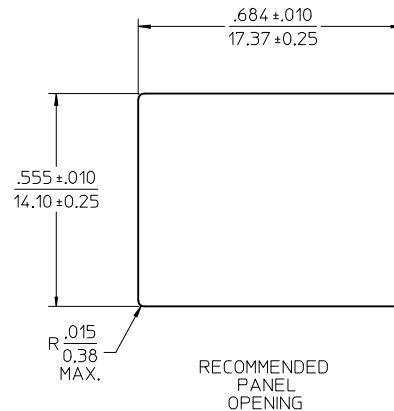

RECOMMENDED PANEL OPENING

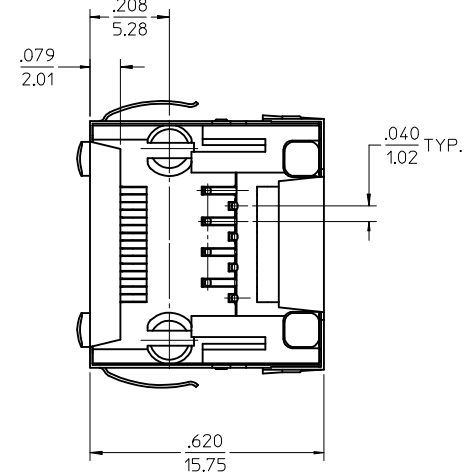

NOTES:

- 1) MATERIAL:
HOUSING: NYLON(PA), GLASS FILLED, UL94V-0, COLOR: BLACK
TERMINALS: PHOSPHOR BRONZE
SHIELD: BRASS
LIGHT PIPES:
POLYCARBONATE - WAVE OR HAND SOLDER ONLY (NOT DESIGNED FOR I/R REFLOW OR CONVECTION REFLOW SOLDER PROCESSES)
POLYSULFONE - MAXIMUM REFLOW TEMPERATURE 400°F (205°C)
- 2) FINISH:
TERMINALS:
SELECT GOLD IN CONTACT AREA: 50 MICROINCHES/1.27 MICROMETERS MIN.
SELECT TIN IN PC TAIL AREA: 100 MICROINCHES/2.54 MICROMETERS MIN.
WITH OVERALL NICKEL UNDERPLATE: 50 MICROINCHES/1.27 MICROMETERS MIN.
SHIELD:
100 MICROINCHES/2.54 MICROMETERS OVER 50 MICROINCHES/1.27 MICROMETERS COPPER UNDERPLATE, PCB GROUND TABS DIPPED IN TIN
- 3) PRODUCT SPECIFICATION AND PROCESSING PARAMETERS: PS-43860-003.
- 4) PACKAGING SPECIFICATION:
CONNECTOR ASSEMBLIES PACKAGED IN THERMOFORMED TRAYS PER MOLEX PACKAGING SPECIFICATION PK-43860-005.
- 5) APPLICATION SPECIFICATION: AS-43860-001
- 6) ALL UNTOLERANCED DIMENSIONS ARE SHOWN FOR REFERENCE ONLY.
- 7) CONFORMS TO FCC REGULATION PART 68.5 FOR MODULAR JACKS.
- 8) AVAILABLE WITH THE (2) SPECIFIED PANEL GROUND TABS OMITTED FOR SIDE TO SIDE STACKABILITY, PER THE ASSEMBLY MATERIAL NUMBER TABLE.
- 9) REFER TO SHEET (5) OF (5) FOR RECOMMENDED PCB LAYOUT.
- 10) THIS PART CONFORMS TO CLASS B REQUIREMENTS OF COSMETIC SPECIFICATION PS-45499-002.

ASSEMBLY MAT. NUM.	LIGHT PIPE MATERIAL	CONNECTOR SIZE	DIM "A"	CIRCUITS	PANEL GROUND TABS
43860-0010	POLYCARBONATE	8	.469/11.91	8	ALL
43860-0011	POLYCARBONATE	6	.389/9.88	6	ALL
43860-0012	POLYCARBONATE	6	.389/9.88	4	ALL
43860-0016	POLYCARBONATE	8	.469/11.91	8	SEE NOTE #8
43860-0017	POLYCARBONATE	6	.389/9.88	6	SEE NOTE #8
43860-1010	POLYSULFONE	8	.469/11.91	8	ALL
43860-1011	POLYSULFONE	6	.389/9.88	6	ALL
43860-1016	POLYSULFONE	8	.469/11.91	8	SEE NOTE #8

SEE SHEET 1 EC NO: UCP2017-0469 DRWNAFENG02 2016/08/30 CHKD: APPR:KLANG 2016/08/31 H10	QUALITY SYMBOLS 	GENERAL TOLERANCES (UNLESS SPECIFIED)		DIMENSION STYLE IN/MM		SCALE 4:1	DESIGN UNITS INCH	THIRD ANGLE PROJECTION	
		4 PLACES ± --- ± --- 3 PLACES ± --- ± .010 2 PLACES ± 0.25 ± --- 1 PLACE ± --- ± --- 0 PLACE ± ±	mm INCH	DRAWN BY TALEND	DATE 1997/02/13	TITLE INVERTED MODULAR JACK ASSEMBLY			
		ANGULAR ±1/2°		CHECKED BY ROBERTS	DATE 1997/03/03	MATERIAL NO. SD-43860-001			
		DRAFT WHERE APPLICABLE MUST REMAIN WITHIN DIMENSIONS		APPROVED BY FRY	DATE 1997/03/04	DOCUMENT NO. SD-43860-001		SHEET NO. 4 OF 5	

THIS DRAWING CONTAINS INFORMATION THAT IS PROPRIETARY TO MOLEX INCORPORATED AND SHOULD NOT BE USED WITHOUT WRITTEN PERMISSION

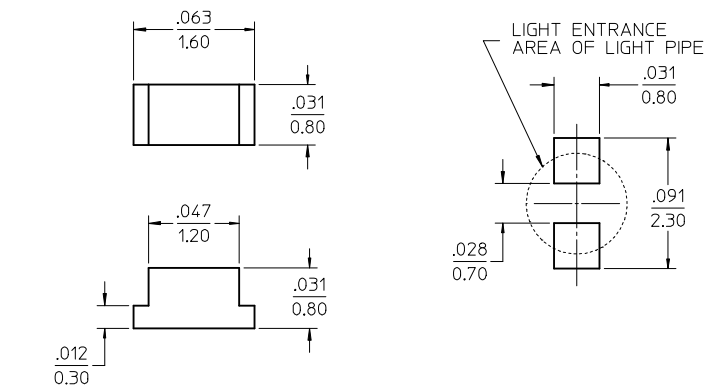
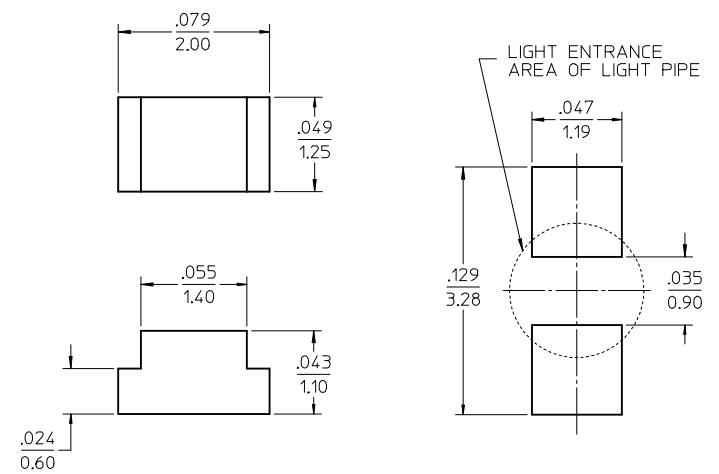
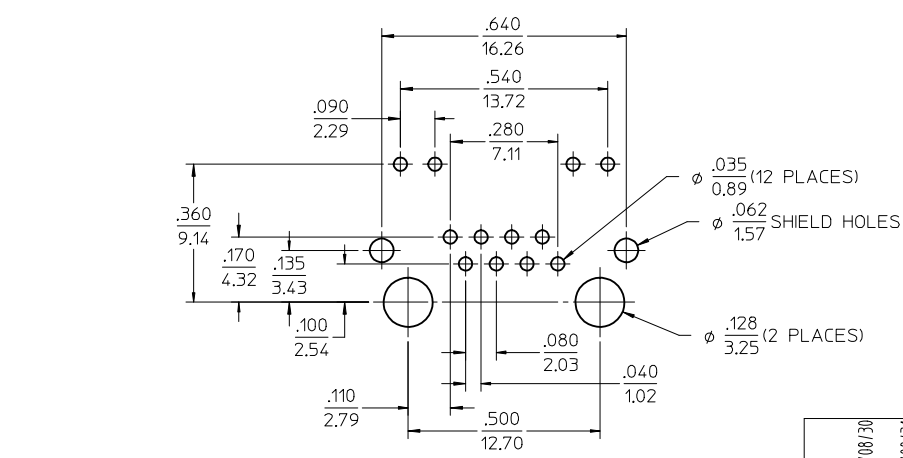
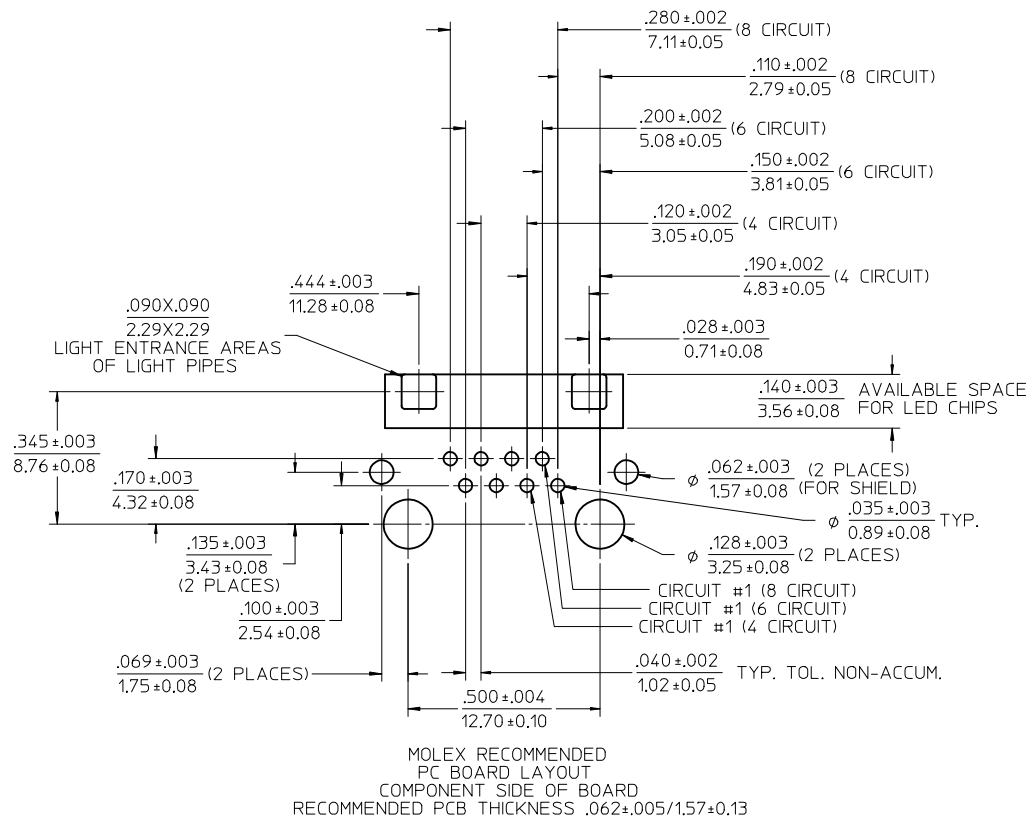

NOTES:
1. FOR CROSS REFERENCE OF RECOMMENDED LED'S SEE MOLEX WEB SITE

SEE SHEET 1 EC NO: UCP2017-0469 DRAWN: AFENGZ 2016/08/30 CHKD: APPR: KLANG 2016/08/31 H10	QUALITY SYMBOLS ▽=0 ▽=0 ▽=0	GENERAL TOLERANCES (UNLESS SPECIFIED)		DIMENSION STYLE		SCALE	DESIGN UNITS	THIRD ANGLE PROJECTION	
				IN/MM		4:1	INCH		
		DRAWN BY		DATE		TITLE		INVERTED MODULAR JACK ASSEMBLY	
		CHECKED BY		DATE		mmm INCH 4 PLACES ± --- ± --- 3 PLACES ± --- ± .010 2 PLACES ± 0.25 ± --- 1 PLACE ± --- ± --- 0 PLACE ± ±			
APPROVED BY		DATE		MATERIAL NO.		DOCUMENT NO.			
DRAFT WHERE APPLICABLE MUST REMAIN WITHIN DIMENSIONS		SEE CHART		SD-43860-001		SHEET NO. 5 OF 5			
THIS DRAWING CONTAINS INFORMATION THAT IS PROPRIETARY TO MOLEX INCORPORATED AND SHOULD NOT BE USED WITHOUT WRITTEN PERMISSION									